



10K PSI / 700 BAR / 7000M

SuperG55™ High-Pressure Subsea



G55 OF1 oil filled straight cable connector plug with clamped hose (CCP-OF)



SuperG55™ CCP-OF - How To Order					
Sample Part Number	G55	OF1	15	03	-0001
Series	SuperG55™ = Underwater dry-mate				
Connector Style	OF1 = Oil filled cable connector plug				
Shell Size	15, 20, 24				
Number of Contacts	See contact arrangements (page 23)				
Cable Length	in feet (0001 = 1 foot, 0002 = 2 feet, etc.)				

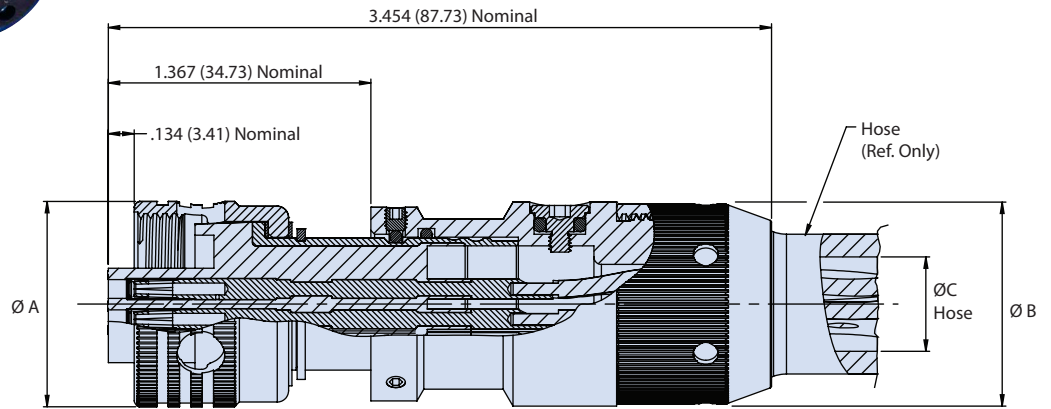
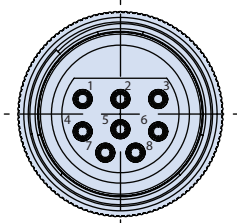

Dimensions			
Shell Size	Dim A Nominal	Dim B ±.15 (.006)	Dim C ±.25 (.10)
15	1.070 (27.18)	1.063 (27.00)	.500 (12.70)
20	1.450 (36.85)	1.441 (36.60)	.750 (19.05)
24	1.700 (43.20)	1.687 (42.84)	.750 (19.05)

NOTES

- 1508 Pin configuration shown. Other pin configurations available
- All contacts / pin configurations suit 16 AWG wire

SUBSEA/DEEPWATER: SUPERG55™

