



10K PSI / 700 BAR / 7000M

SuperG55™ High-Pressure Subsea



Attachable, G55 A1 cable connector plug (CCP-AT)



SuperG55™ CCP - How To Order					
Sample Part Number	G55	A1	15	03	-0001
Series	SuperG55™ = Underwater dry-mate				
Connector Style	A1 = Cable connector plug, attachable				
Shell Size	15, 20, 24				
Number of Contacts	See contact arrangements (page 23)				
Cable Length	In feet (0001 = 1 foot, 0002 = 2 feet, etc.)				

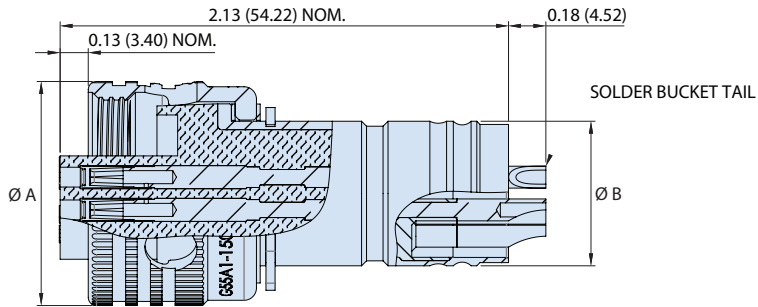
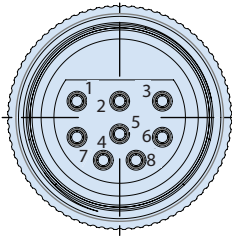

SUBSEA/ DEEPWATER: SUPERG55™

Dimensions			
Shell Size	Dim A ±.006 (.15)	Dim B ±.002 (.05)	Dim C ±.002 (.05)
15	1.070 (27.18)	.688 (17.48)	.681 (17.30)
20	1.450 (36.85)	1.093 (27.76)	1.073 (27.26)
24	1.700 (43.20)	1.312 (33.32)	1.288 (32.72)
32	2.350 (56.77)	1.811 (46.00)	1.783 (45.30)

NOTES

- 1508 Pin configuration shown. Other pin configurations available
- All contacts / pin configurations suit 16 AWG wire