



10K PSI / 700 BAR / 7000M SuperG55™ High-Pressure, Dry-Mate Subsea Connectors



G55 06 flange connector receptacle (FCR)



SuperG55™ FCR - How To Order					
Sample Part Number	G55	06	15	08	-0001
Series	SuperG55™ = Underwater dry-mate				
Connector Style	06 = Flange connector receptacle				
Shell Size	15, 20, 24				
Number of Contacts	See contact arrangements (page 23)				
Cable Length	In feet (0001 = 1 foot, 0002 = 2 feet, etc.)				

SUBSEA/ DEEPWATER: SUPERG55™

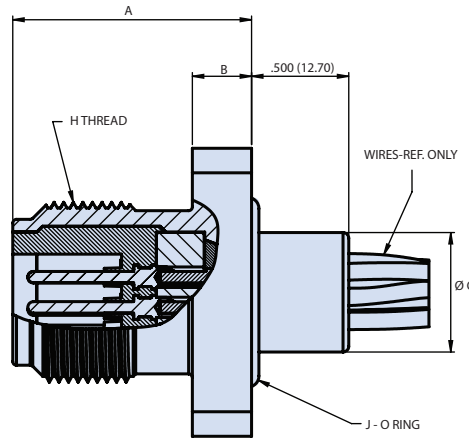
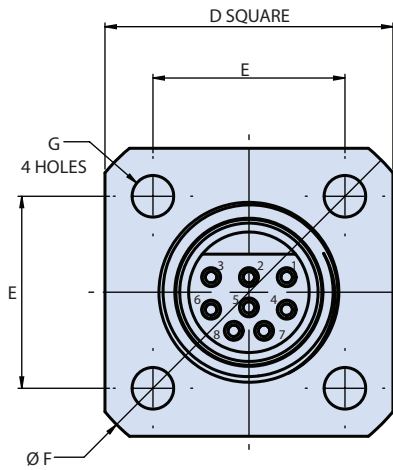

PANEL CUTOUT DIMENSIONS

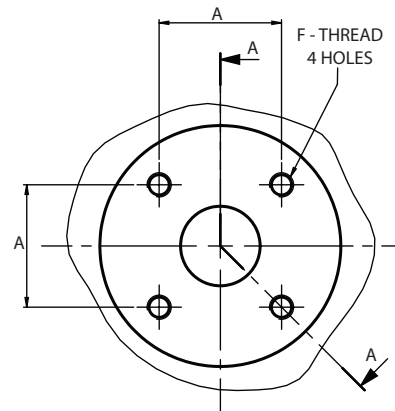

Dimensions					
Shell Size	Dim A ±.010 (.26)	Dim B ±.015 (.39)	Dim C ±.002 (.05)	Dim D ±.005 (.13)	Dim E ±.002 (.05)
15	1.250 (31.75)	.314 (7.98)	.622 (15.80)	1.500 (38.10)	1.000 (25.4)
20	1.500 (38.10)	.374 (9.50)	.737 (18.73)	1.750 (44.45)	1.250 (31.75)
24	1.500 (38.10)	.374 (9.50)	.987 (25.08)	2.000 (50.80)	1.500 (38.10)

Dimensions (continued)				
Shell Size	Dim F ±.005 (.13)	Dim G +.004/-0 (+.10/-0)	H Thread	J - O Ring
15	1.949 (49.50)	.217 (5.50)	15/16"-20UNEF-2A	BS1806-116
20	2.299 (58.40)	.276 (7.00)	1 1/4"-9 STUB ACME	BS1806-118
24	2.626 (66.70)	.276 (7.00)	1 1/2"-9 STUB ACME	BS1806-122

Panel Mount Dimensions						
Shell Size	Dim A ±.004 (.10)	Dim B Min	Dim C ±.005 (.13)	Dim D ±.005 (.13)	E Thread Depth Typical	F - Thread
15	1.000 (25.40)	.525 (13.3)	.650 (16.50)	1.980 (50.30)	.315 (8.00)	M5 x 0.8-6H
20	1.250 (31.75)	.625 (15.88)	.770 (19.56)	2.33 (59.18)	.375 (9.52)	M6 x 1.0-6H
24	1.500 (38.10)	.625 (15.88)	1.020 (25.91)	2.655 (67.44)	.375 (9.52)	M6 x 1.0-6H

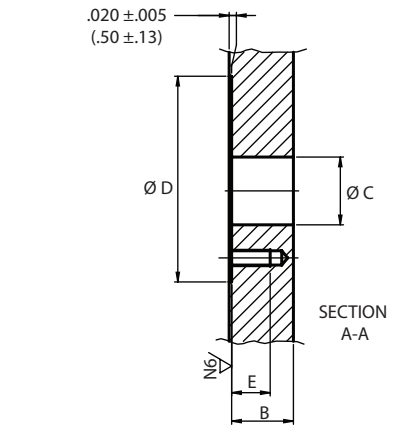

NOTES

- 1508 Pin configuration shown. Other pin configurations available
- All contacts / pin configurations suit 16 AWG wire