



10K PSI / 700 BAR / 7000M SuperG55™ High-Pressure, Dry-Mate Subsea Connectors



G55 01 straight overmolded cable plug (CCP)



SuperG55™ CCP - How To Order					
Sample Part Number	G55	01	15	03	-0001
Series	SuperG55™ = Underwater dry-mate				
Connector Style	01 = Cable connector plug				
Shell Size	15, 20, 24				
Number of Contacts	See contact arrangements (page 23)				
Cable Length	In feet (0001 = 1 foot, 0002 = 2 feet, etc.)				

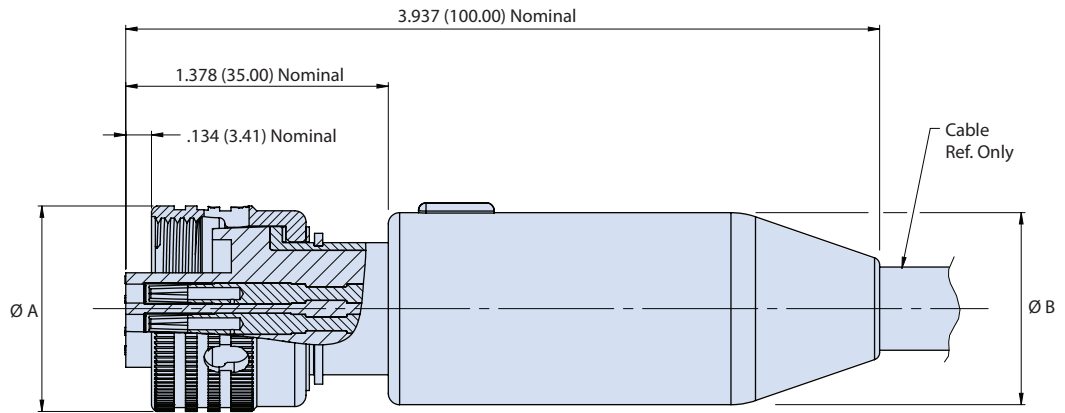
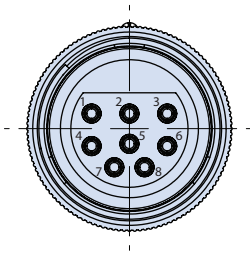

Dimensions		
Shell Size	Dim A ±.006 (.15)	Dim B ±.010 (.25)
15	1.070 (27.18)	1.000 (25.40)
20	1.450 (36.83)	1.380 (35.05)
24	1.700 (43.18)	1.640 (41.66)

NOTES

- 1508 Pin configuration shown. Other pin configurations available
- All contacts / pin configurations suit 16 AWG wire

SUBSEA/DEEPWATER: SUPERG55™

