



SERIES 70 10K PSI / 700 BAR / 7000 M

SeaKing™ High-Pressure Subsea Connectors, Cables, and PBOF Assemblies



PBOF assembly fittings and accessories

REVOLUTIONARY PBOF SWIVEL HOSE ATTACHMENT ACCESSORIES

Hose barb fittings for PBOF assemblies are the perennial weak link in subsea oil & gas applications. Kinked and twisted hoses, leaky fittings, corroded hose clamps, and general poor performance characterize most existing solutions. The Glenair PBOF swivel hose attachment for SeaKing™ connectors solves these problems and more. Designed from the sea floor up to perform flawlessly and reliably, this revolutionary attachment puts an end to the long list of field maintenance problems associated with oil-filled cable applications.

- **Straight, 45°, and 90° “full radius” angle and profile hose routing**
- **Hose angle adjustment feature eliminates risk of oil leakage**
- **Corrosion-resistant materials used throughout**
- **Threaded couplers with safety set-screws for fail-safe leak and decoupling protection—no special tools required for assembly**
- **Compact PBOF compression fitting with 340° hose swivel action**
- **Support for the broad range of hose diameters and wall thicknesses**

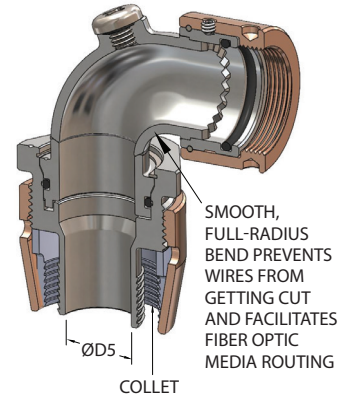

ACCESSORY TEETH MESH WITH TEETH ON BACK END OF PLUG ASSEMBLY, ALLOWING TUBING END OF PBOF TO BE CLOCKED IN DESIRED DIRECTION

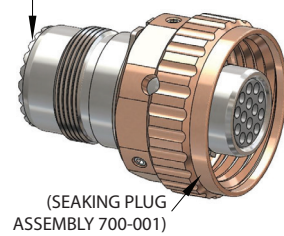

SeaKing PBOF Attachment Accessory Kits - How To Order					
Sample Part Number	709-123	K	-L	1	S
Product Series	709-123 = SeaKing™ PBOF accessory				
Shell Size	E, G, K, L, M, O, P, Q, R				
Angular Function	L = Straight M = 45° N = 90°				
Fill Port Option	0 = No fill port 1 = With fill port				
Swivel/Fixed Option	S = Swivel F = Fixed				

The complete range of SeaKing PBOF hose compression fittings includes straight, 45°, and 90° full radius profile versions; with and without integrated oil fill ports

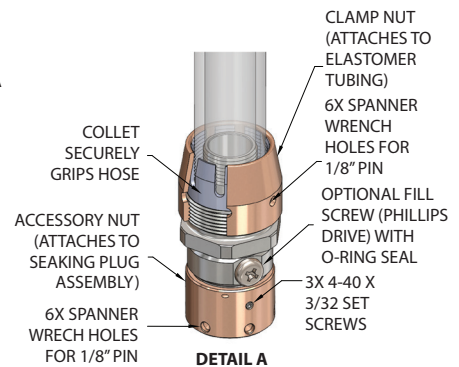
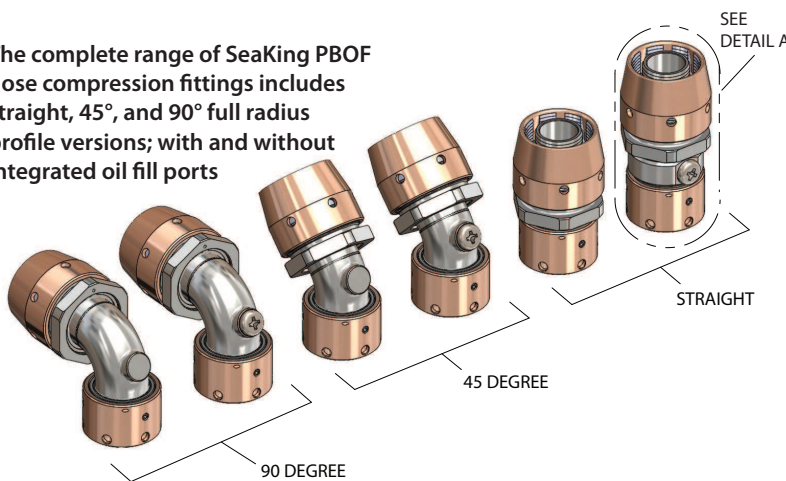

SUBSEA/DEEPWATER: SEAKING™



SERIES 70 10K PSI / 700 BAR / 7000 M

SeaKing™ High-Pressure Subsea Connectors, Cables, and PBOF Assemblies



PBOF fitting: straight with fill port and swivel

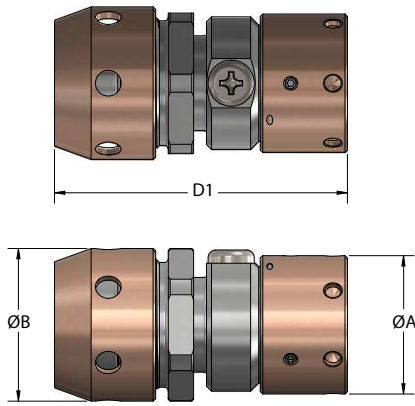

709-003-L1S
STRAIGHT, WITH FILL PORT, SWIVEL

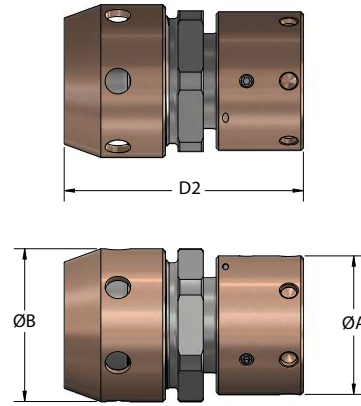

709-003-L0S
STRAIGHT, WITHOUT FILL PORT, SWIVEL

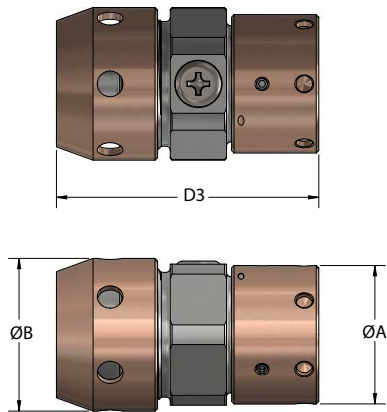

709-003-L1F
STRAIGHT, WITH FILL PORT, FIXED

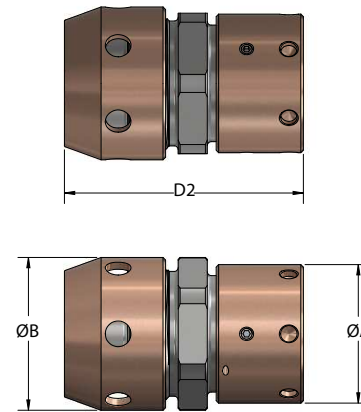
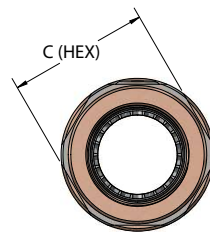

709-003-L0F
STRAIGHT, WITHOUT FILL PORT, FIXED

Dimensions					
Dim Callout	Shell Size				
	G	K	M	O	Q
A	0.97 (24.64)	1.10 (27.94)	1.35 (34.29)	1.60 (40.64)	1.85 (46.99)
B	1.08 (27.43)	1.21 (30.73)	1.40 (35.56)	1.58 (40.13)	1.83 (46.48)
C	0.99 (25.15)	1.11 (28.19)	1.30 (33.02)	1.49 (37.85)	1.80 (45.72)
D1	2.32 (58.93)	2.32 (58.93)	2.40 (60.96)	2.32 (58.93)	2.41 (61.21)
D2	1.89 (48.01)	1.89 (48.01)	1.97 (50.04)	1.89 (48.01)	1.98 (50.29)
D3	2.08 (52.83)	2.08 (52.83)	2.16 (54.86)	2.08 (52.83)	2.08 (52.83)

SUBSEA/DEEPWATER: SEAKING™





SERIES 70 10K PSI / 700 BAR / 7000 M
**SeaKing™ High-Pressure Subsea
 Connectors, Cables, and PBOF Assemblies**
 PBOF fitting: 45° with fill port and swivel

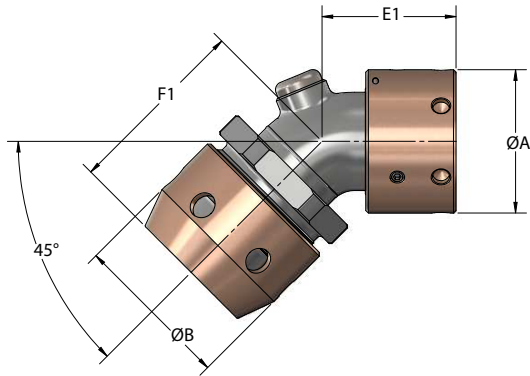

709-003 -M1S
 45°, WITH FILL PORT, SWIVEL

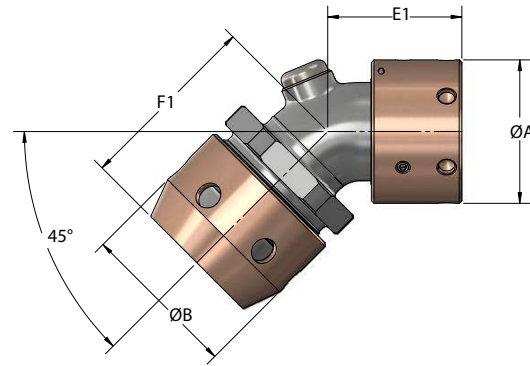

709-003 -M1F
 45°, WITH FILL PORT, FIXED

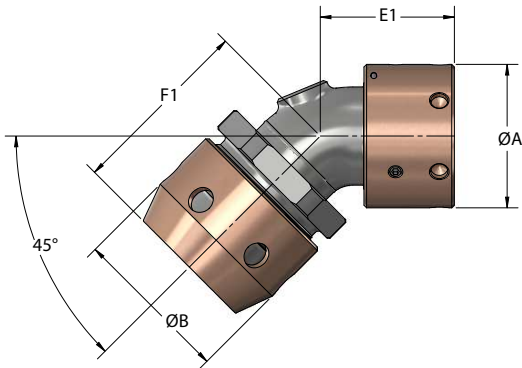
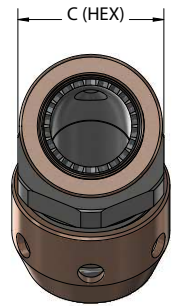

709-003 -M0S
 45°, WITHOUT FILL PORT, SWIVEL

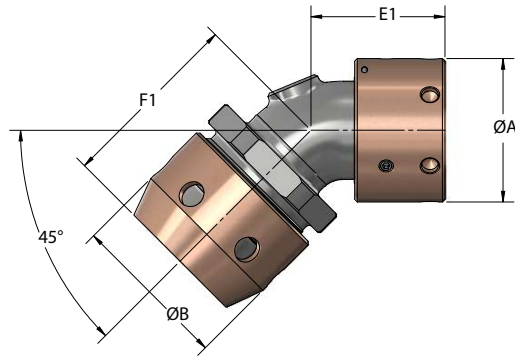

709-003 -M0F
 45°, WITHOUT FILL PORT, FIXED

SUBSEA/DEEPWATER: SEAKING™



Dimensions					
Dim Callout	Shell Size				
	G	K	M	O	Q
A	0.97 (24.64)	1.10 (27.94)	1.35 (34.29)	1.60 (40.64)	1.85 (46.99)
B	1.08 (27.43)	1.21 (30.73)	1.40 (35.56)	1.58 (40.13)	1.83 (46.48)
C	0.99 (25.15)	1.11 (28.19)	1.30 (33.02)	1.49 (37.85)	1.80 (45.72)
E1	1.01 (25.65)	1.07 (27.18)	1.14 (28.96)	1.22 (30.99)	1.33 (33.78)
F1	1.42 (36.07)	1.48 (37.59)	1.63 (41.40)	1.63 (41.40)	1.83 (46.48)



SERIES 70 10K PSI / 700 BAR / 7000 M
**SeaKing™ High-Pressure Subsea
 Connectors, Cables, and PBOF Assemblies**
 PBOF fitting: 90° with fill port and swivel

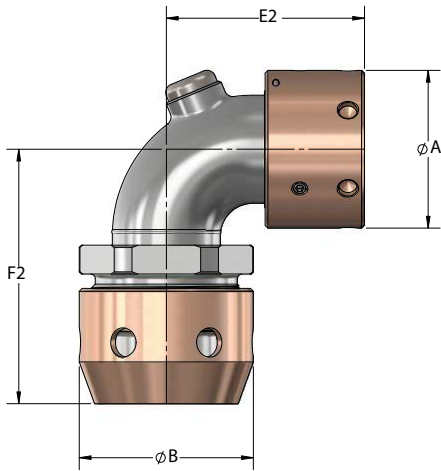

709-003-N1S
 90°, WITH FILL PORT, SWIVEL

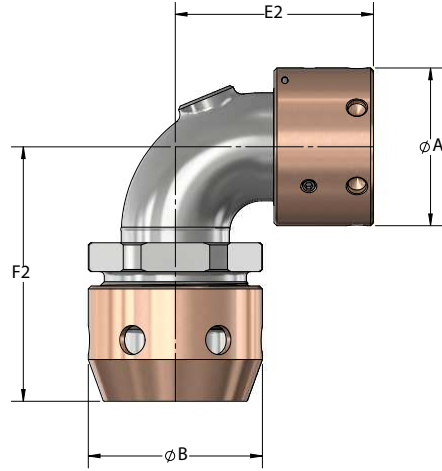

709-003-N0S
 90°, WITHOUT FILL PORT, SWIVEL

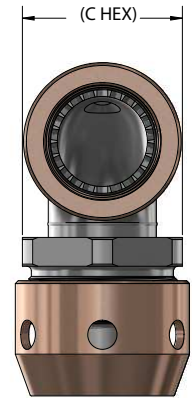

SUBSEA/DEEPWATER: SEAKING™

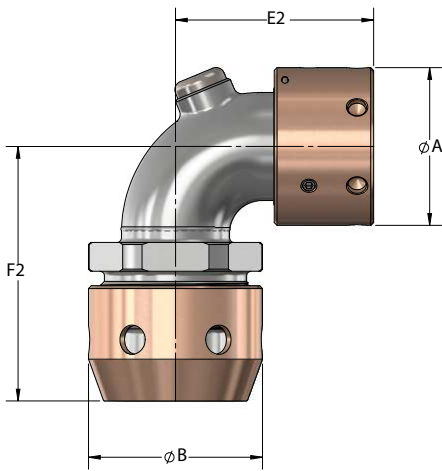

709-003-N1F
 90°, WITH FILL PORT, FIXED

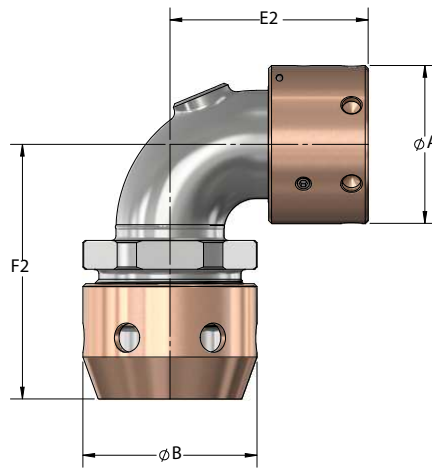

709-003-N0F
 90°, WITHOUT FILL PORT, FIXED

Dimensions					
Dim Callout	Shell Size				
	G	K	M	O	Q
A	0.97 (24.64)	1.10 (27.94)	1.35 (34.29)	1.60 (40.64)	1.85 (46.99)
B	1.08 (27.43)	1.21 (30.73)	1.40 (35.56)	1.58 (40.13)	1.83 (46.48)
C	0.99 (25.15)	1.11 (28.19)	1.30 (33.02)	1.49 (37.85)	1.80 (45.72)
E2	1.24 (31.50)	1.36 (34.54)	1.54 (39.12)	1.72 (43.69)	1.96 (49.78)
F2	1.65 (41.91)	1.77 (44.96)	2.03 (51.56)	2.13 (54.10)	2.46 (62.48)



SERIES 70 10K PSI / 700 BAR / 7000 M



SeaKing™ High-Pressure Subsea Connectors, Cables, and PBOF Assemblies

PBOF tubing: flexible elastomer

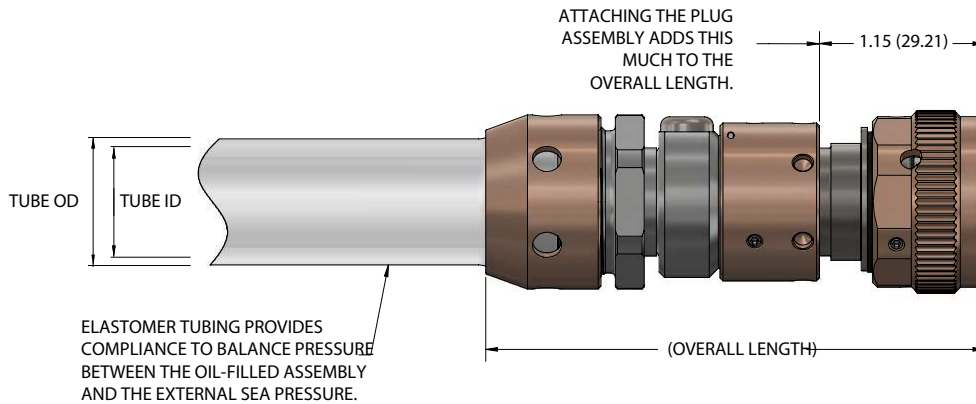
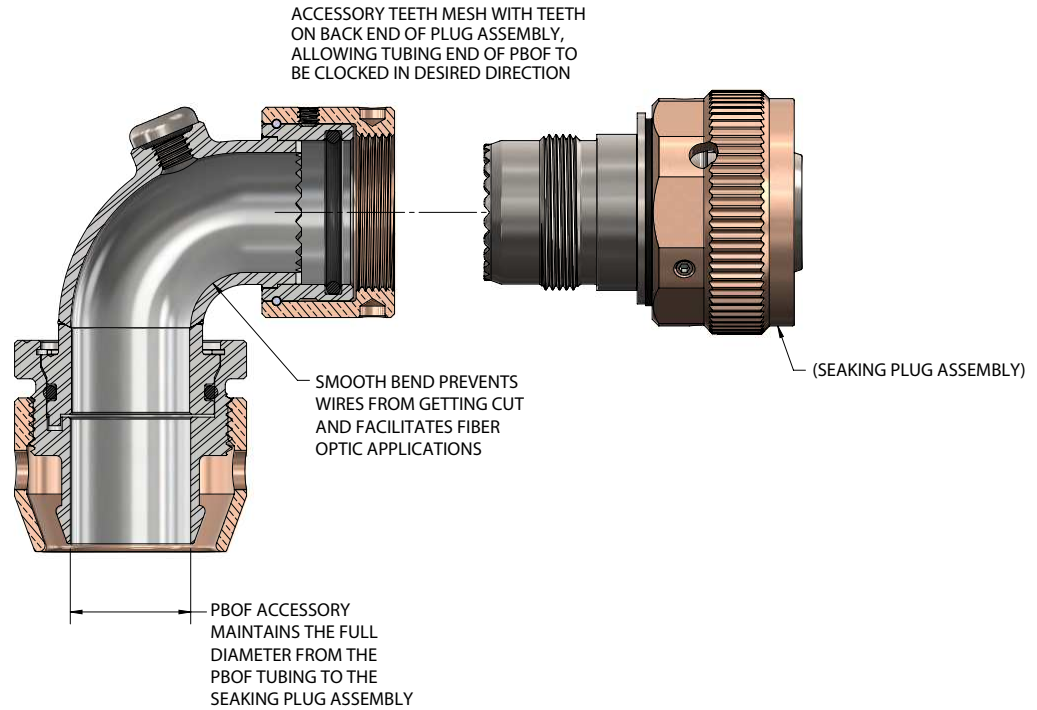

Dimensions and Performance Data

SeaKing Shell Size	Tube I.D.	Tube O.D.	Wall Thickness	Min Bend Radius	Max Working Pressure		Vacuum Rating Inches of Mercury	
					@ 73F°	@ 180F°	@ 73F°	@ 180° F
E	3/8	5/8	1/8	1 1/2	205	115	29.9	29.9
G	1/2	3/4	1/8	2	195	110	29.9	29.9
K	5/8	7/8	1/8	3	175	105	29.9	25.0
M	3/4	1 1/16	5/32	3 1/2	150	100	29.9	25.0
O	1	1 3/8	3/16	4 3/4	120	80	29.9	15.0
Q	1 1/4	1 3/4	1/4	6	95	65	29.9	20.0

SUBSEA/DEEPWATER: SEAKING™