

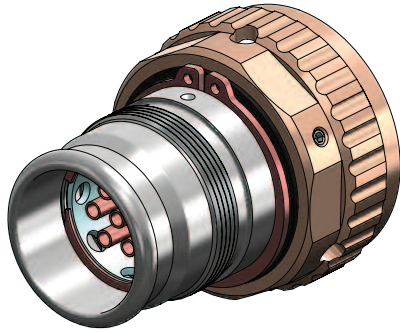

SERIES 70 10K PSI / 700 BAR / 7000 M SeaKing™ High-Pressure Subsea Connectors, Cables, and PBOF Assemblies

707-0413 cable connector plug (CCP)



SeaKing Plug - How To Order						
Sample Part Number	707	-0413-	K19	-Z1	S	N 1147
Product Series	707 = SeaKing™					
Connector Style	0413 = Cable connector plug					
Shell Size-Contact Arrangement	See SeaKing contact arrangements table (pgs. 4-5)					
Barrel Material	Z1 = Stainless steel TC = Titanium					
Contact Style	S = Socket					
Alternate Key Position	A, B, C, N = Normal (see alternate key positions table)					
Color Band	1147 = Color band per Polarization Table Blank = No Color Band					

NOTES

1. Double O-ring sealing in mated condition
2. Mates with 700-006 / -007 series SeaKing receptacles of the same size and polarization
3. Retractable coupling nut facilitates O-ring servicing
4. Material/Finish
 - Barrel: 316 stainless steel or titanium
 - Coupling nut: marine bronze or titanium
 - Contacts: Copper alloy, gold plated
 - Insulator: Composite thermoplastic
 - Set screw: Stainless steel or titanium
 - O-ring: Nitrile (NBR)

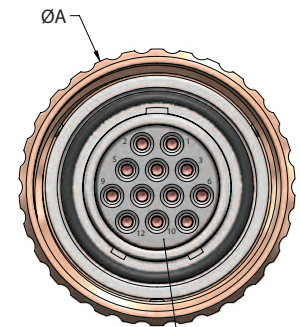
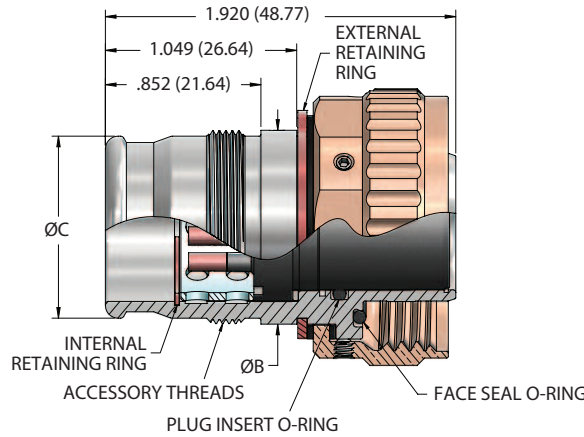

INSULATOR SHOWN FOR REFERENCE ONLY. SEE 709-099 FOR COMPLETE LIST OF AVAILABLE CONTACT ARRANGEMENTS.

Alternate Key Positions

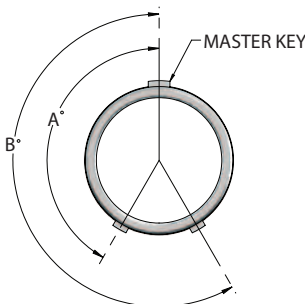

Position	A°	B°	Color Band (Optional)
N	150°	210°	Blue
A	75°	210°	Yellow
B	95°	230°	Orange
C	140°	275°	Red

Dimensions

Shell Size	A	B	C	External Retaining Ring Stainless Steel 11	External Retaining Ring Titanium 11	Internal Retaining Ring Stainless Steel 11	Face Seal O-Ring	Plug Insert O-Ring	Accessory Threads (Un-2a)	Mating Torque (Ft-Lbs)
G	1.139	0.688	0.622	709-063-068	709-054-068	709-055-50	2-015	2-012	11/16-28	10
K	1.264	0.812	0.747	709-063-081	709-054-081	709-055-62	2-017	2-014	13/16-28	12
L	1.389	0.938	0.872	709-063-093	709-054-093	709-055-75	2-019	2-016	15/16-28	12
M	1.514	1.062	0.997	709-063-106	709-054-106	709-055-81	2-020	2-017	11/16-28	12
O	1.764	1.312	1.247	709-063-131	709-054-131	709-055-100	2-024	2-020	15/16-28	15
P	1.889	1.438	1.372	709-063-143	709-054-143	709-055-112	2-026	2-022	17/16-28	15
Q	2.014	1.562	1.497	709-063-156	709-054-156	709-055-125	2-028	2-024	19/16-20	15
R	2.139	1.688	1.622	709-063-168	709-054-168	709-055-137	2-029	2-026	11/16-20	15

SUBSEA/DEEPWATER: SEAKING™

