



# SERIES 70 10K PSI / 700 BAR / 7000 M SeaKing™ High-Pressure Subsea Connectors, Cables, and PBOF Assemblies

## 700-001 cable connector plug (CCP)



SeaKing Plug - How To Order						
Sample Part Number	700	-001-	K19	-Z1	S	N
Product Series	700 = SeaKing™					
Connector Style	001 = Cable connector plug					
Shell Size-Contact Arrangement	See SeaKing contact arrangements table (pgs. 4-5)					
Barrel Material	Z1 = 316 Stainless steel TC = Titanium					
Contact Style	S = Socket					
Alternate Key Position	A, B, C, N = Normal (see alternate key positions table)					

### NOTES

1. Double O-ring sealing in mated condition
2. Mates with 700-006 / -007 series SeaKing receptacles of the same size and polarization
3. Retractable coupling nut facilitates O-ring servicing
4. Material/Finish
  - Barrel: 316 stainless steel or titanium
  - Coupling nut: marine bronze
  - Contacts: Copper alloy, gold plated
  - Insulator: Composite thermoplastic
  - Set screw: 316 stainless steel
  - O-ring: Nitrile (NBR)

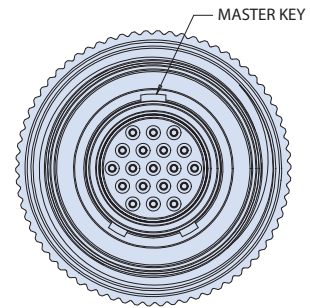
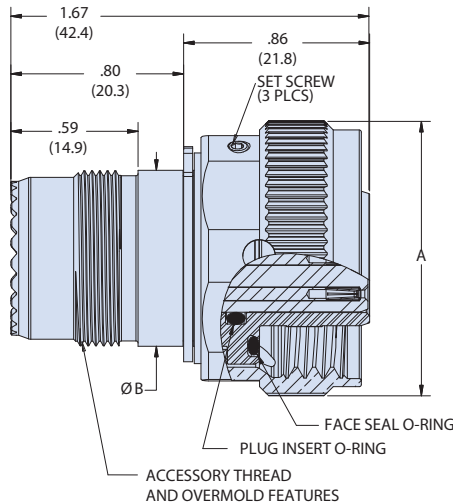

SUBSEA/DEEPWATER: SEAKING™

### Alternate Key Positions

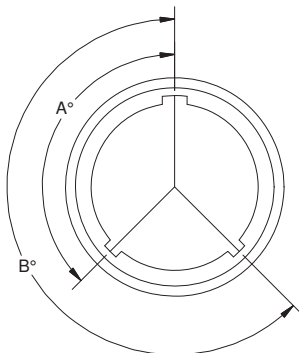

Position	A°	B°
N	150°	210°
A	75°	210°
B	95°	230°
C	140°	275°

### Dimensions

Shell Size	Ø A	Ø B	Face seal O-ring	Plug insert O-ring	Accessory Thread	Set Screw	Mating Torque
G	1.15 (29.21)	0.69 (17.53)	015	012	1 1/16-28 UN-2A	4-40 x 3/32	10 ft/lbs
K	1.27 (32.26)	0.81 (20.57)	017	014	1 3/16-28 UN-2A		12 ft/lbs
L	1.38 (35.05)	0.94 (23.88)	019	016	1 5/16-28 UN-2A		12 ft/lbs
M	1.51 (38.35)	1.06 (26.92)	020	017	1 1/2-28 UN-2A		12 ft/lbs
O	1.74 (44.20)	1.31 (33.27)	024	020	1 5/8-28 UN-2A		15 ft/lbs
Q	2.01 (51.05)	1.56 (39.62)	028	024	1 3/4-20 UN-2A		15 ft/lbs
R	2.14 (54.36)	1.69 (42.93)	029	026	1 7/8-20 UN-2A		15 ft/lbs