



# SERIES 701 SeaKing™ Junior High-Density PEEK Subsea Connectors



## 701-038 PEEK Cable Connector Plug with crimp-removable contacts

HOW TO ORDER					
Sample Part Number	701-038	-17-08	-K	S	N
Product Series	701-038 = SeaKing Junior				
Shell Size-Contact Arrangement	See Contact Arrangements table				
Barrel Material	K = 30% Reinforced PEEK				
Contact Style	A = Pin Insert (No Contacts Included) B = Socket Insert (No Contacts Included) P = Pin S = Socket				
Key Position	A, B, C, D, E (See table)				

### NOTES

Pressure rating: Mated condition - 5,000 PSI, tested per ISO 13628-6.  
Materials tested to:  
- Salt spray, per MIL-STD-202 method 101  
- Humidity, per MIL-STD-202 method 101  
- Thermal cycle, per EIA-455-71  
Single O-ring sealing.

### MATERIAL/FINISH

Plug barrel: 30% reinforced PEEK  
Coupling nut: 30% reinforced PEEK  
Contacts: Copper alloy, gold plated  
Insulator: High grade rigid dielectric  
Retaining ring: 316 stainless steel  
Interfacial seal (pin inserts only): Fluorosilicone

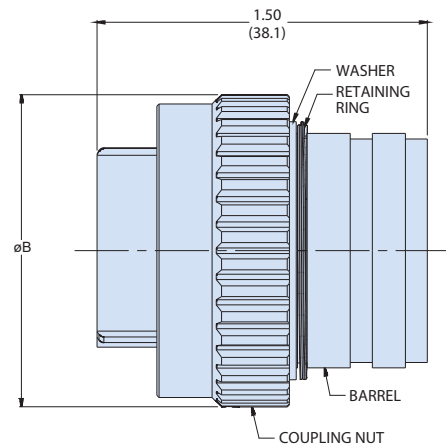
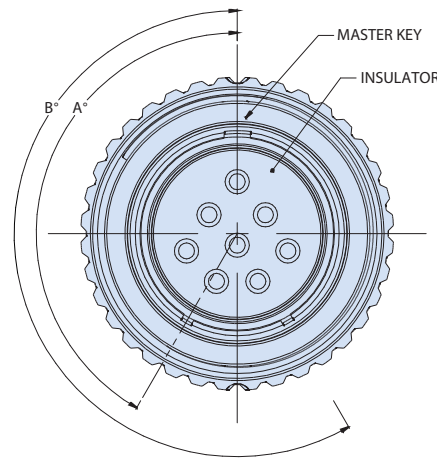

Shell Size	Thread A	Ø B	
		In.	mm
09	0.7500-20 UNEF-2B	0.935	23.7
11	0.8750-20 UNEF-2B	1.060	26.9
13	1.0000-20 UNEF-2B	1.185	30.1
15	1.1250-20 UN-2B	1.310	33.3
17	1.2500-20 UN-2B	1.435	36.4
19	1.3750-20 UN-2B	1.560	39.6
21	1.5000-20 UN-2B	1.685	42.8
23	1.6250-20 UN-2B	1.810	46.0
25	1.7500-20 UN-2B	1.935	49.1

Position	ALTERNATE KEY POSITIONS	
	A°	B°
N	150°	210°
A	75°	210°
B	95°	230°
C	140°	275°
D	75°	275°
E	95°	210°