

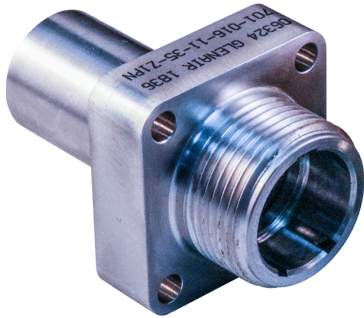

SERIES 701 SeaKing™ Junior Dry-Mate Subsea Connectors



701-016 Flange Connector Receptacle, high density with crimp removable contacts



HOW TO ORDER					
Sample Part Number	701-016	-17-08	-Z1	P	N
Product Series	701-016 = SeaKing Junior				
Shell Size-Contact Arrangement	See Contact Arrangements table				
Barrel Material	Z1 = 316 Stainless Steel* TC = Titanium XO = PEEK**				
Contact Style	A = Pin Insert (No Contacts Included) B = Socket Insert (No Contacts Included) P = Pin S = Socket				
Key Position	A, B, C, D, E (See table)				

* 316 Stainless steel for sizes 09 2507 Super duplex for sizes 11 through 25
** Consult factory for pressure rating

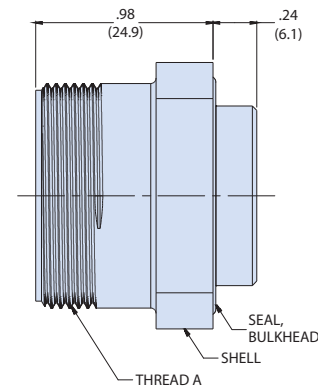
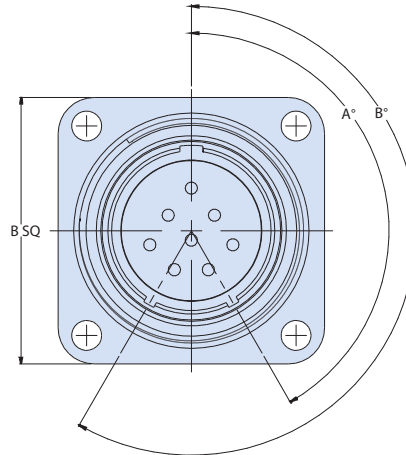
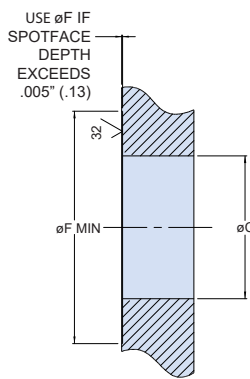

DIMENSIONS														
Shell Size	Thread A	B MAX		C*		D*		E* Flange Screw Size	F Min, .005		F' Min, >.005		Bulkhead Seal	Bore Seal
		inch	mm	inch	mm	inch	mm		inch	mm	inch	mm		
09	0.7500-20 UNEF-2A	1.085	27.6	0.530	13.5	0.770	19.6	#4-40	0.885	22.5	1.460	37.1	2-017	2-014
11	0.8750-20 UNEF-2A	1.175	29.8	0.655	16.6	0.860	21.8	#4-40	1.015	25.8	1.600	40.6	2-019	2-016
13	1.0000-20 UNEF-2A	1.265	32.1	0.760	19.3	0.950	24.1	#4-40	1.120	28.4	1.690	42.9	2-021	2-018
15	1.1250-20 UN-2A	1.405	35.7	0.895	22.7	1.070	27.2	#6-32	1.250	31.8	1.955	49.7	2-023	2-020
17	1.2500-20 UN-2A	1.495	38.0	1.020	25.9	1.160	29.5	#6-32	1.375	34.9	2.065	52.5	2-025	2-022
19	1.3750-20 UN-2A	1.710	43.4	1.125	28.6	1.250	31.8	#8-32	1.480	37.6	2.320	58.9	2-026	2-024
21	1.5000-20 UN-2A	1.850	47.0	1.250	31.8	1.390	35.3	#8-32	1.610	40.9	2.485	63.1	2-028	2-026
23	1.6250-20 UN-2A	1.940	49.3	1.350	34.3	1.480	37.6	#8-32	1.705	43.3	2.520	64.0	2-029	2-028
25	1.7500-20 UN-2A	2.030	51.6	1.500	38.1	1.570	39.9	#8-32	1.855	47.1	2.745	69.7	2-030	2-029

*For dimension see next page.

NOTES

Pressure rating: Mated condition - 5,000 PSI
Materials tested to:
- Salt spray, per MIL-STD-202 method 101
- Humidity, per MIL-STD-202 method 101
- Thermal cycle, per EIA-455-71
Single O-ring sealing.

MATERIAL/FINISH

Receptacle shell: See part number development
Contacts: Copper alloy, gold plated
Insulator: High grade rigid dielectric
Interfacial seal (pin inserts only) & grommet:
Fluorosilicone
Seals: Nitrile



SERIES 701 SeaKing™ Junior Dry-Mate Subsea Connectors



701-016 Flange Connector Receptacle,
high density with crimp removable contacts

ALTERNATE KEY POSITIONS		
Position	A°	B°
N	150°	210°
A	75°	210°
B	95°	230°
C	140°	275°
D	75°	275°
E	95°	210°

