

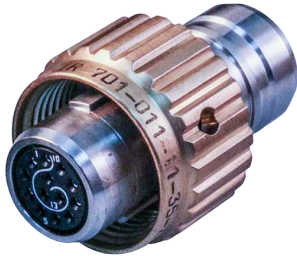

SERIES 701 SeaKing™ Junior Dry-Mate Subsea Connectors



701-011 Plug, High Density with crimp removable contacts



HOW TO ORDER					
Sample Part Number	701-011	-13-08	-Z1	S	N
Product Series	701-011 = SeaKing Junior				
Shell Size-Contact Arrangement	See Contact Arrangements table				
Barrel Material	Z1 = 316 Stainless Steel* (Marine Bronze Coupling Nut) TC = Titanium XO = PEEK**				
Contact Style	A = Pin Insert (No Contacts Included) B = Socket Insert (No Contacts Included) P = Pin S = Socket				
Key Position	A, B, C, D, E (See table)				

* 316 Stainless steel for sizes 09 through 19 2507 Super duplex for sizes 21 through 25
** Consult factory for pressure rating

NOTES

Pressure rating: Mated condition - 5,000 PSI

Materials tested to:

- Salt spray, per MIL-STD-202 method 101
- Humidity, per MIL-STD-202 method 101
- Thermal cycle, per EIA-455-71

Single O-ring sealing.

MATERIAL/FINISH

Plug barrel: See part number development

Coupling nut: Marine bronze for Z1 connectors
Titanium for TC connectors

Contacts: Copper alloy, gold plated

Insulator: High grade rigid dielectric

Retaining ring: 316 stainless steel

Interfacial seal (pin inserts only):

Fluorosilicone

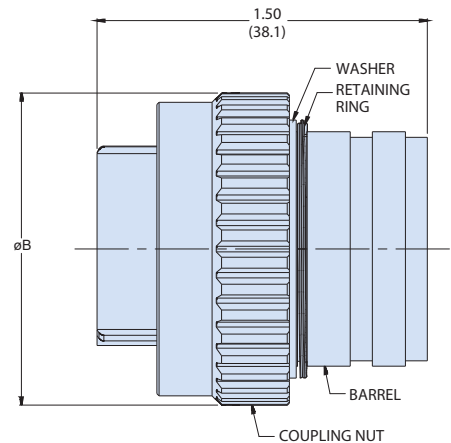
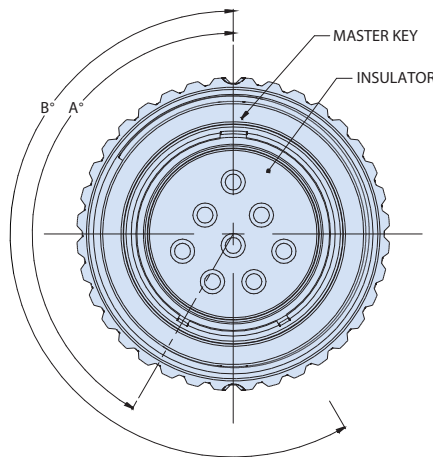

DIMENSIONS			
Shell Size	Thread A	Ø B Max	
		In.	mm
09	0.7500-20 UNEF-2B	0.935	23.7
11	0.8750-20 UNEF-2B	1.060	26.9
13	1.0000-20 UNEF-2B	1.185	30.1
15	1.1250-20 UN-2B	1.310	33.3
17	1.2500-20 UN-2B	1.435	36.4
19	1.3750-20 UN-2B	1.560	39.6
21	1.5000-20 UN-2B	1.685	42.8
23	1.6250-20 UN-2B	1.810	46.0
25	1.7500-20 UN-2B	1.935	49.1

ALTERNATE KEY POSITIONS		
Position	A°	B°
N	150°	210°
A	75°	210°
B	95°	230°
C	140°	275°
D	75°	275°
E	95°	210°