

**290-011 and 290-012
Stainless Steel Molding Adapters**

STAINLESS STEEL MOLDING ADAPTERS, STANDARD OR WITH OPTIONAL CABLE ENTRY DIAMETERS



How To Order		
Sample Part Number	290WS011	-18
Basic Number	290WS011	
Shell Size	See Table I	



How To Order			
Sample Part Number	290WS012	-18	12
Basic Number	290WS012		
Shell Size	See Table II		
Cable Entry Size	See Table II		

Tips

To select the appropriate molding adapter, consider the following basic suggestions to ensure a high integrity, quality molded termination:

- Select a molding adapter which will provide adequate inside working room to accept the termination envelope, especially if there are shield terminations, splices, etc.
- If the termination is to be molded with neoprene or other material using a transfer molding process, select the molding adapter cable entry diameter close to the outside diameter of the cable or termination envelope.

NOTES

1. Prior to use, lubricate O-rings with high grade silicone lubricant (Molykote M55 or equivalent).
2. Material:
Adapter - stainless steel.
O-ring - nitrile

290WS011 STANDARD

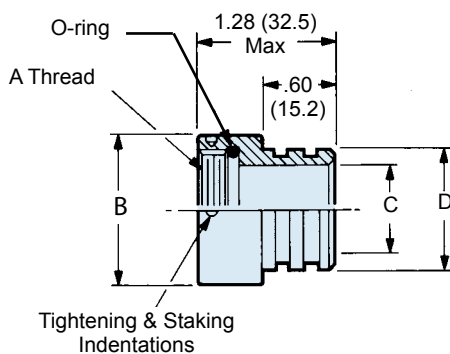

290WS012 OPTIONAL CABLE ENTRY DIAMETERS

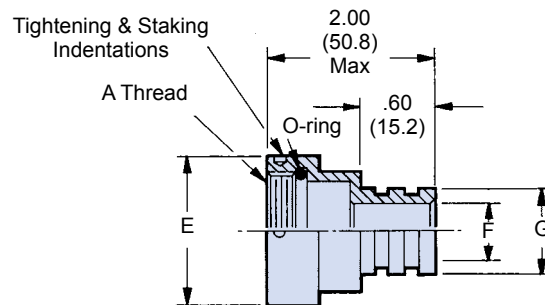



SERIES 22 5000M / 5000 PSI Shallow Water Application



290-011 and 290-012 Stainless Steel Molding Adapters

SUBSEA/SHALLOW WATER: GEO-MARINE®

Table I: 290WS011 Fixed Entry Dimensions				
Shell Size	A Thread Class 2B	B Dia Max	C Dia	D Dia
10	5/8 - 24 UNEF	.855 (21.7)	.430 (10.9)	.670 (17.0)
12	3/4 - 20 UNEF	.965 (24.5)	.535 (13.6)	.780 (19.8)
14	7/8 - 20 UNEF	1.090 (27.7)	.660 (16.8)	.905 (23.0)
16	1 - 20 UNEF	1.220 (31.0)	.785 (19.9)	1.020 (25.9)
18	1 1/8 - 16 UN	1.370 (34.8)	.880 (22.4)	1.135 (28.8)
20	1 1/4 - 16 UN	1.525 (38.7)	1.005 (25.5)	1.250 (31.8)
22	1 3/8 - 16 UN	1.655 (42.0)	1.130 (28.7)	1.383 (35.1)
24	1 1/2 - 16 UN	1.775 (45.1)	1.255 (31.9)	1.510 (38.4)

Table II: 290WS012 Variable Entry Dimensions					
Shell Size	A Thread Class 2B	E Dia Max	Max Entry	F Dia	G Dia
10	5/8 - 24 UNEF	.855 (21.7)		.430 (10.9)	.670 (17.0)
12	3/4 - 20 UNEF	.965 (24.5)	12	.535 (13.6)	.780 (19.8)
14	7/8 - 20 UNEF	1.090 (27.7)		.660 (16.8)	.905 (23.0)
16	1 - 20 UNEF	1.220 (31.0)	16	.785 (19.9)	1.020 (25.9)
18	1 1/8 - 16 UN	1.370 (34.8)		.880 (22.4)	1.135 (28.8)
20	1 1/4 - 16 UN	1.525 (38.7)	20	1.005 (25.5)	1.250 (31.8)
22	1 3/8 - 16 UN	1.655 (42.0)		1.130 (28.7)	1.383 (35.1)
24	1 1/2 - 16 UN	1.775 (45.1)	24	1.255 (31.9)	1.510 (38.4)

Table IV: Torque Values	
Entry No.	Torque ± 5 In. Lbs.
10	80
12	100
14	120
16	120
18	140
20	140
22	140
24	150

Table V: Replacement O-Ring Part Numbers *	
Shell Size	Piston O-Ring
10	2-014
12	2-016
14	2-018
16	2-020
18	2-022
20	2-024
22	2-026
24	2-028

* Parker o-ring part numbers.
Compound N674-70 or equivalent.

INSTRUCTIONS FOR USING CABLE MOLDING ADAPTERS

- Slide 290WS011/012 adapter over cable
- Prepare cable and wires
- If using shrink sleeves, slide them over wire insulation and solder terminated wires to solder cup contacts; slide shrink sleeves to correct position and apply recommended heat.
- Slide 290WS011/012 adapter and attach hand-tight to plug connector.
- Use Plug Holding Tool (P/N 600-005) along with Hand Held Torque Wrench (P/N 600-076) and Spanner Wrench (P/N 600-171) to tighten to recommended torque value.

Please note that the "tightening/staking indentations" are on the 290WS011/012 Adapter, NOT on the Marine Bronze Coupling Nut. The "holes" in the coupling nut retain the spring for the anti-decoupling feature of the cable plug.

The TG70 Strap Wrench and the 600-076 Torque Wrench should be utilized to properly torque the cable/plug assembly to the appropriate receptacle