



SERIES 22 5000M / 5000 PSI Shallow Water Application



290-003 and 290-004

Environmental Backshell with Strain-Relief Clamp

90°, 45° OR STRAIGHT ENVIRONMENTAL BACKSHELL AND/OR CABLE CLAMP



		How To Order									
Sample Part Number		290	W	A	003	NF	-16	10	H	6	
Product Series	290										
Connector Designator	W										
Angular Function	A = 90° H = 45° S = Straight										
Basic Part Number	003 = Strain Relief 004 = Environmental Seal/Strain Relief										
Material/Finish	B, G, M, GB, NF, Z1 See Table IV,										
Shell Size	-10, -12, -14, -16, -18, -20, -22, -24, -28 See Table I										
Cable Entry Dash No.	04, 06, 08, 10, 12, 16, 18, 20, 24, 28, See Table II										
Strain Relief Style	H = Cable Clamp, Table II K = Cable Grip, Table III										
Length (S Only)	1/2 inch Increments, e.g. 6 = 3.0 inches; See Note 2										

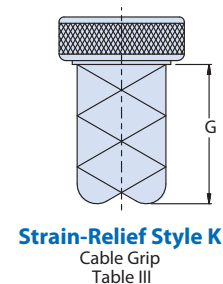
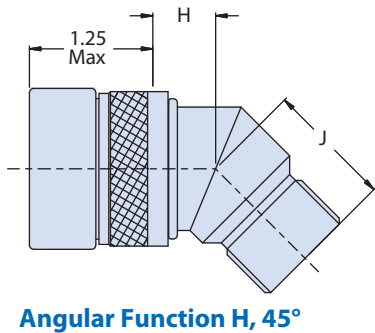
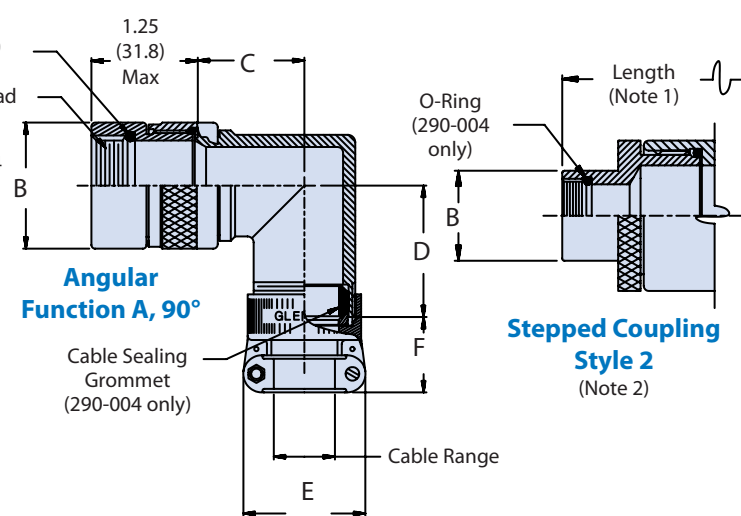
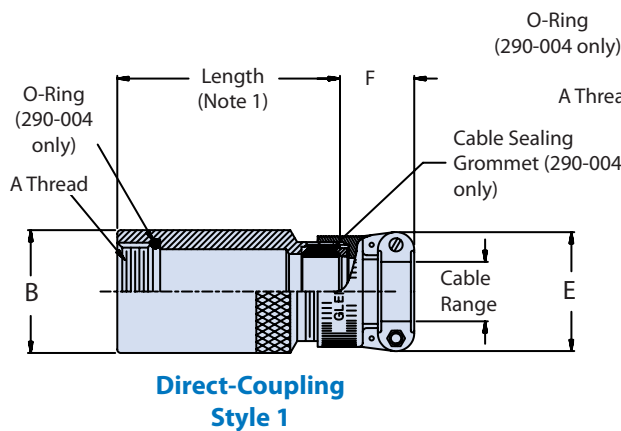

SUBSEA/SHALLOW WATER: GEO-MARINE®





SERIES 22 5000M / 5000 PSI Shallow Water Application



290-003 and 290-004

Environmental Backshell with Strain-Relief Clamp

Shell Size	A Thread Class 2B	B Dia Max
10	5/8-24 UNEF	0.781 (19.8)
12	3/4-20 UNEF	0.906 (23.0)
14	7/8-20 UNEF	1.031 (26.2)
16	1-20 UNEF	1.156 (29.4)
18	1 1/8-16 UN	1.281 (32.5)
20	1 1/4-16 UN	1.406 (35.7)
22	1 3/8-16 UN	1.531 (38.9)
24	1 1/2-16 UN	1.656 (42.1)
26	1 5/8-18 UNEF	1.781 (45.2)
28	1 3/4-18 UNS	1.906 (48.4)

Dash No.	C Max	D Max	E Max	F Max	H Max	J Max	Cable Entry	
							Min	Max
04	0.94 (23.9)	1.16 (29.5)	0.957 (24.3)	0.780 (19.8)	0.74 (18.8)	0.95 (24.1)	0.125 (3.2)	0.312 (7.9)
06	0.98 (24.9)	1.22 (31.0)	1.145 (29.1)	0.780 (19.8)	0.76 (19.3)	0.98 (24.9)	0.250 (6.4)	0.437 (11.1)
08	1.03 (26.2)	1.25 (31.8)	1.332 (33.8)	0.780 (19.8)	0.78 (19.8)	1.00 (25.4)	0.312 (7.9)	0.562 (14.3)
10	1.09 (27.7)	1.32 (33.5)	1.332 (33.8)	0.780 (19.8)	0.80 (20.3)	1.03 (26.2)	0.350 (8.9)	0.625 (15.9)
12	1.12 (28.4)	1.36 (34.5)	1.551 (39.4)	0.811 (20.6)	0.82 (20.8)	1.05 (26.7)	0.500 (12.7)	0.750 (19.1)
16	1.25 (31.8)	1.45 (36.8)	1.770 (45.0)	0.905 (23.0)	0.87 (22.1)	1.09 (27.7)	0.625 (15.9)	0.937 (23.8)
20	1.41 (35.8)	1.65 (41.9)	2.113 (53.7)	1.092 (27.7)	1.14 (29.0)	1.35 (34.3)	0.875 (22.2)	1.250 (31.8)
24	1.41 (35.8)	1.65 (41.9)	2.363 (60.0)	1.124 (28.5)	1.14 (29.0)	1.35 (34.3)	1.000 (25.4)	1.375 (34.9)
28	1.60 (40.6)	1.88 (47.8)	2.770 (70.4)	1.399 (35.5)	1.27 (32.3)	1.43 (36.3)	1.250 (31.8)	1.625 (41.3)
32	1.60 (40.6)	1.88 (47.8)	3.020 (76.7)	1.399 (35.5)	1.27 (32.3)	1.43 (36.3)	1.437 (36.5)	1.875 (47.6)

Dash No	G Length Ref	Grip Range			
		Min		Max	
03	2.12 (53.8)	0.180	(4.6)	0.210	(5.3)
04	2.75 (69.9)	0.210	(5.3)	0.310	(7.9)
06	4.00 (101.6)	0.310	(7.9)	0.438	(11.1)
08	4.12 (104.6)	0.438	(11.1)	0.500	(12.7)
10	4.37 (111.0)	0.500	(12.7)	0.625	(15.9)
12	6.00 (152.4)	0.625	(15.9)	0.750	(19.1)
14	5.00 (127.0)	0.750	(19.1)	0.875	(22.2)
16	6.00 (152.4)	0.875	(22.2)	1.000	(25.4)
20	6.25 (158.8)	1.000	(25.4)	1.250	(31.8)
24	7.25 (184.2)	1.125	(28.6)	1.375	(34.9)

Sym	Finish Description
B	Cadmium Plate/Olive Drab
G	Hard Coat, Mil-A-8625 Color Gray
M	Electroless Nickel
N	Cadmium Plate/Olive Drab Over Nickel Plate
GB	Hard Coat, Mil-A-8625 Color Black
NF	Cad/O. D. Over Electroless Nickel (1000 Hour Salt Spray)
Z1	Stainless Steel Material Passivate Per QQ-P-35

NOTES

1. Assembly identified with manufacturer's name and P/N, space permitting.
2. Standard minimum length for Style I is 1.50 Inch, for Style II is 2.00 Inches. For shorter length, consult factory. Note: applies to Sym S, straight, only.
3. When cable diameter exceeds inside diameter or connector shell, Style II will be supplied.
4. Glenair 600 series backshell assembly tools are recommended for assembly and installation.
5. Material/finish:
Elbows, adapter, coupling & gland nuts, clamp - Al alloy or CRES/see Table II.
Grip, hardware - CRES/passivate.