

SERIES 802 2400M / 3500 PSI Ultraminiature Subsea Connectors



Hybrid PCB footprints
Viewed from component mounting side of PCB

Contact Arrangement

Pin Connector

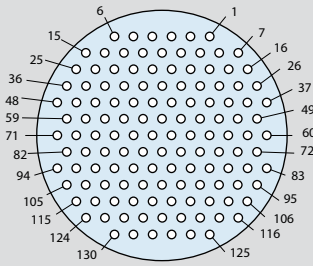

Contact Arrangement

21-130

130 #23 Contacts

.022 (0.56) Max Dia. Tail

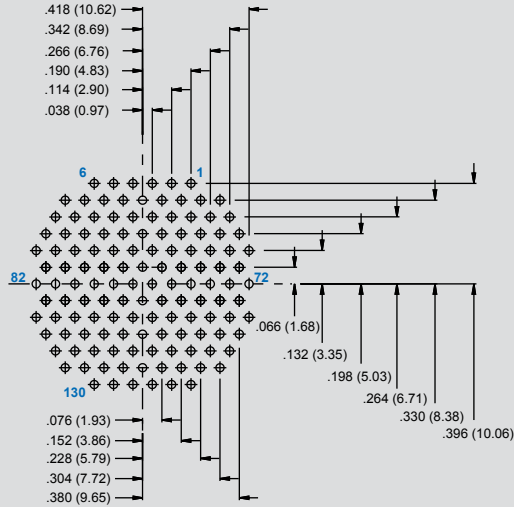

Socket Connector

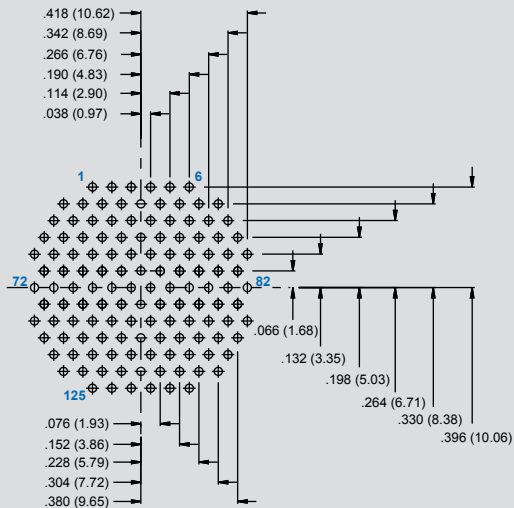

SUBSEA/SHALLOW WATER: AQUAMOUSE™



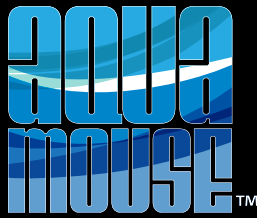

SERIES 802 2400M / 3500 PSI Ultraminiature Subsea Connectors





Hybrid PCB footprints
Viewed from component mounting side of PCB

SUBSEA SHALLOW WATER: AQUAMOUSE™

Contact Arrangement	Pin Connector	Socket Connector
---------------------	---------------	------------------

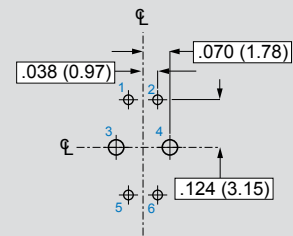
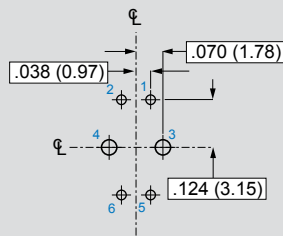

Contact Arrangement 8-200
 2 #20 Contacts
 .028 (0.71) Max. Dia. Tail
 4 #23 Contacts
 .022 (0.56) Max. Dia. Tail

Contact Arrangement 9-200
 4 #23 Contacts
 .022 (0.56) Max. Dia. Tail
 2 #16 Contacts
 .064 (1.63) Max. Dia. Tail



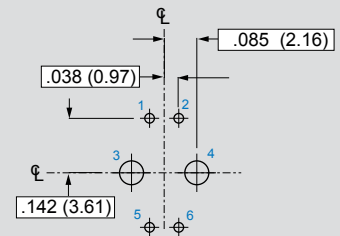
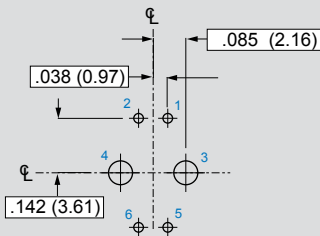
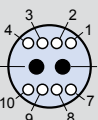

Contact Arrangement 9-201
 2 #20 Contacts
 .028 (0.71) Max Dia Tail
 8 #23 Contacts
 .022 (0.56) Max Dia Tail

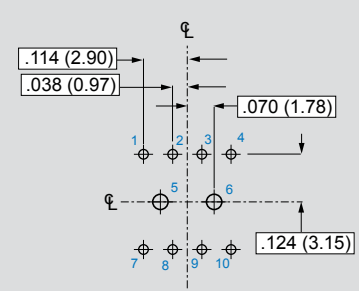
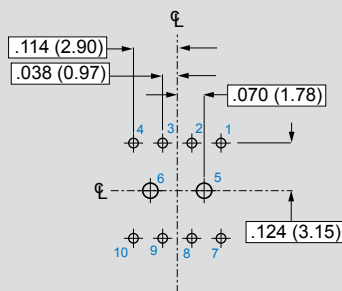

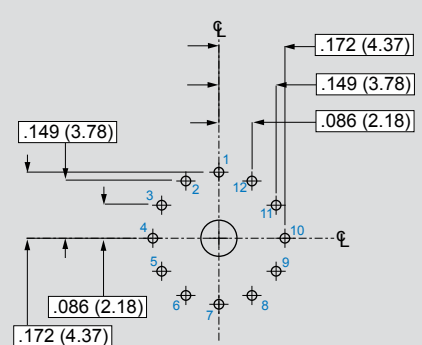
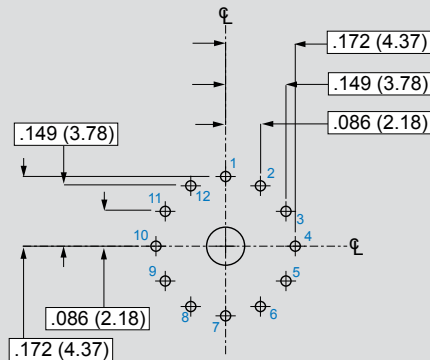
Contact Arrangement 10-200
 1 #12 Contact
 .096 (2.44) Max Dia Tail
 12 #23 Contacts
 .022 (0.56) Max. Dia. Tail

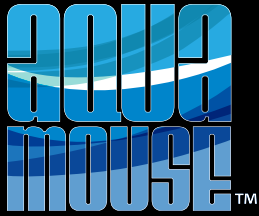



SERIES 802 2400M / 3500 PSI
Ultraminiature Subsea Connectors



Hybrid PCB footprints
 Viewed from component mounting side of PCB

Contact Arrangement

Pin Connector

Socket Connector

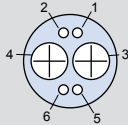

**Contact Arrangement
 10-201**

- 2 #12 Contacts
- .096 (2.44) Max. Dia. Tail
- 4 #23 Contacts
- .022 (0.56) Max. Dia. Tail

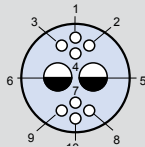
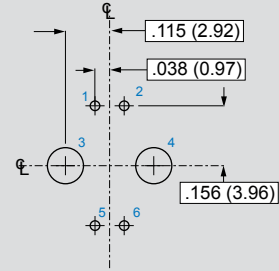
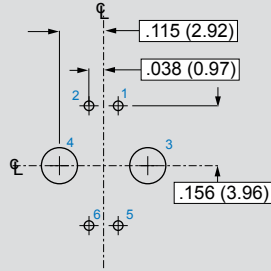

**Contact Arrangement
 10-202**

- 2 #16 Contacts
- .064 (1.63) Max. Dia. Tail
- 8 #23 Contacts
- .022 (0.5 Max. Dia. Tail)

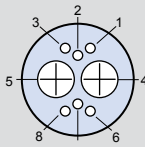
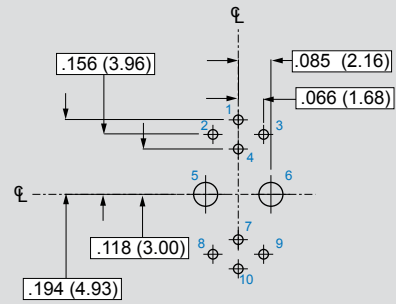
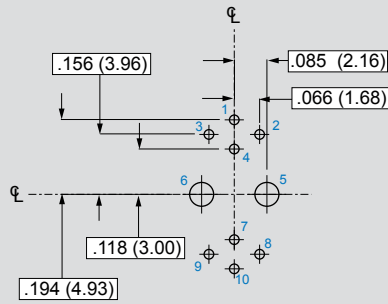

**Contact Arrangement
 12-200**

- 2 #12 Contacts
- .096 (2.44) Max. Dia. Tail
- 6 #23 Contacts
- .022 (0.56) Max. Dia. Tail

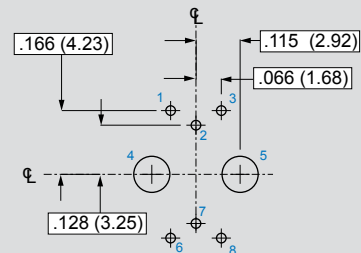
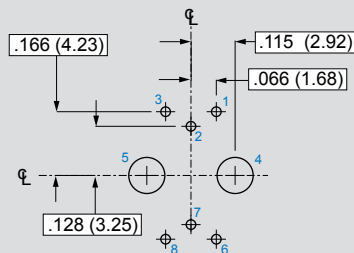

SUBSEA/SHALLOW WATER: AQUAMOUSE™



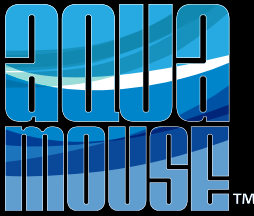

SERIES 802 2400M / 3500 PSI Ultraminiature Subsea Connectors



Hybrid PCB footprints
Viewed from component mounting side of PCB

Contact Arrangement	Pin Connector	Socket Connector
---------------------	---------------	------------------

Contact Arrangement 12-201
 2 #12 Contacts
 .096 (2.44) Max. Dia. Tail
 10 #23 Contacts
 .022 (0.56) Max. Dia. Tail

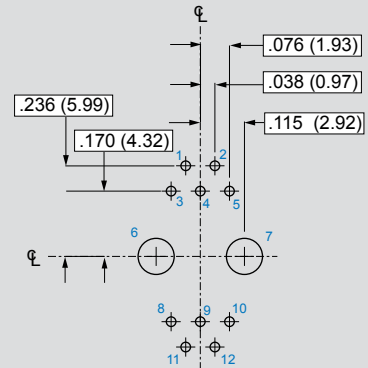
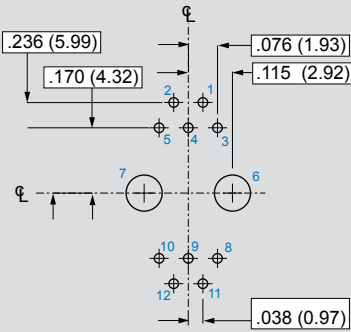

Contact Arrangement 12-202
 2 #16 Contacts
 .064 (1.63) Max. Dia. Tail
 20 #23 Contacts
 .028 (0.71) Max. Dia. Tail

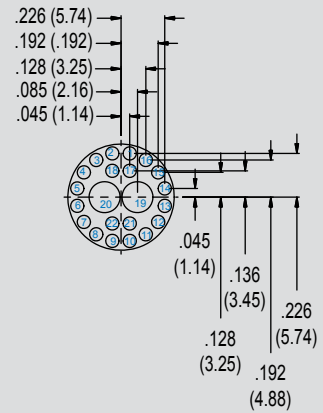
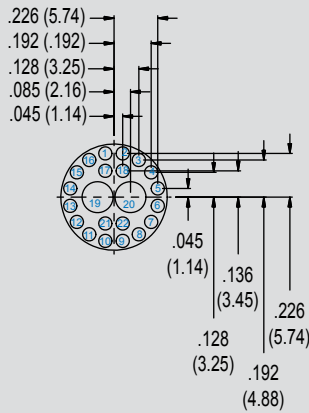

Contact Arrangement 12-203
 4 #16 Contacts
 .064 (1.63) Max. Dia. Tail
 12 #23 Contacts
 .022 (0.71) Max. Dia. Tail

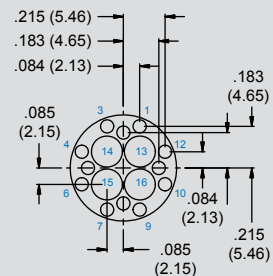
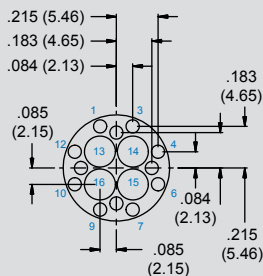

SUBSEA SHALLOW WATER: AQUAMOUSE™



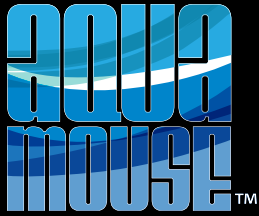

SERIES 802 2400M / 3500 PSI
Ultraminiature Subsea Connectors



Hybrid PCB footprints
 Viewed from component mounting side of PCB

Contact Arrangement

Pin Connector

Socket Connector

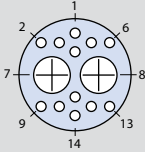

**Contact Arrangement
 12-204**

- 2 #12 Contacts
- .096 (2.44) Max. Dia. Tail
- 12 #23 Contacts
- .022 (0.71) Max. Dia. Tail

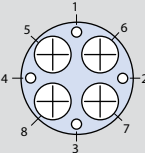
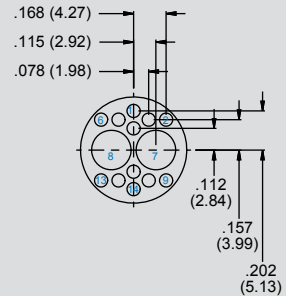
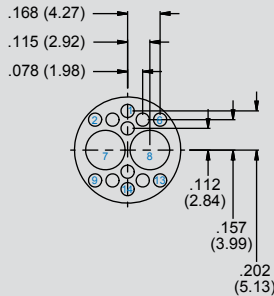

**Contact Arrangement
 12-205**

- 4 #12 Contacts
- .096 (2.44) Max. Dia. Tail
- 4 #23 Contacts
- .022 (0.71) Max. Dia. Tail

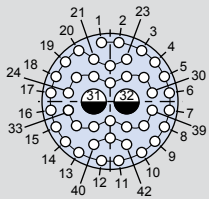
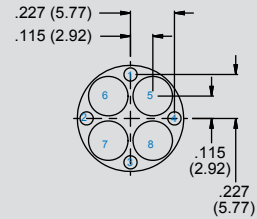
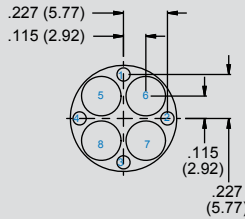

**Contact Arrangement
 14-204**

- 2 #16 Contacts
- .064 (1.63) Max. Dia. Tail
- 40 #23 Contacts
- .022 (0.71) Max. Dia. Tail

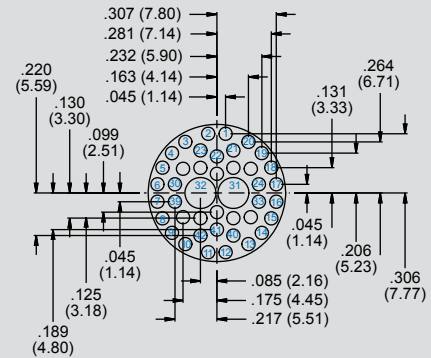
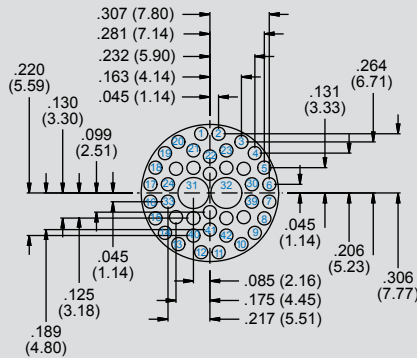

SUBSEA/SHALLOW WATER: AQUAMOUSE™



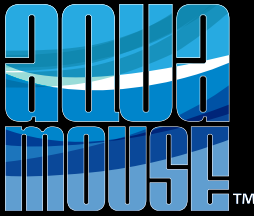

SERIES 802 2400M / 3500 PSI Ultraminiature Subsea Connectors



Hybrid PCB footprints
Viewed from component mounting side of PCB

Contact Arrangement	Pin Connector	Socket Connector
---------------------	---------------	------------------

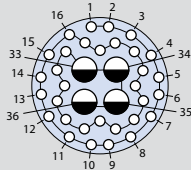

Contact Arrangement 14-205
4 #16 Contacts
.064 (1.63) Max. Dia. Tail
32 #23 Contacts
.022 (0.71) Max. Dia. Tail

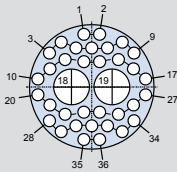
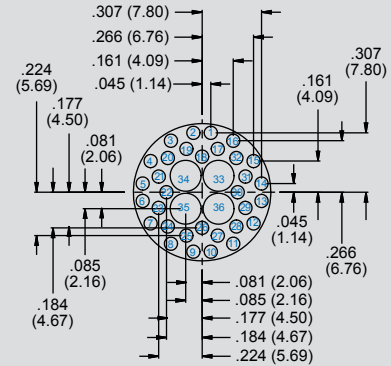
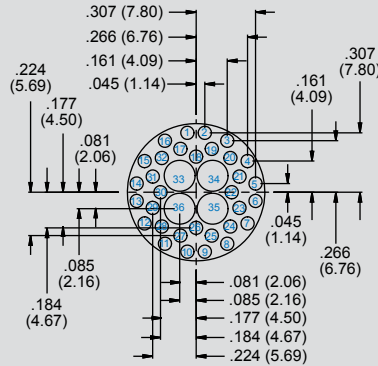

Contact Arrangement 14-206
2 #12 Contacts
.096 (2.44) Max. Dia. Tail
34 #23 Contacts
.022 (0.71) Max. Dia. Tail

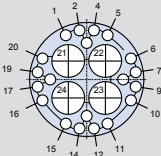
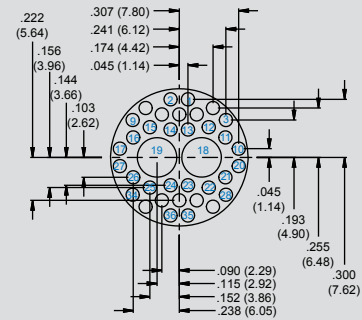
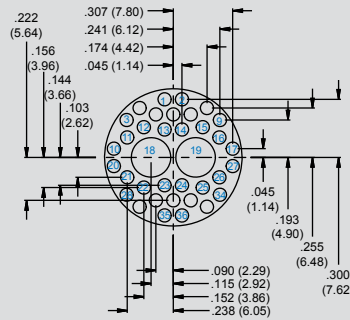

Contact Arrangement 14-207
4 #12 Contacts
.096 (2.44) Max. Dia. Tail
20 #23 Contacts
.022 (0.71) Max. Dia. Tail

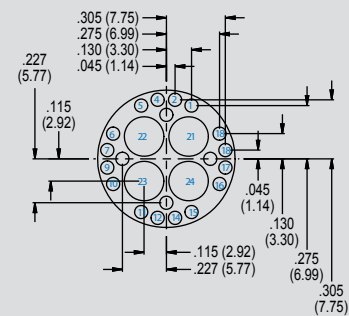
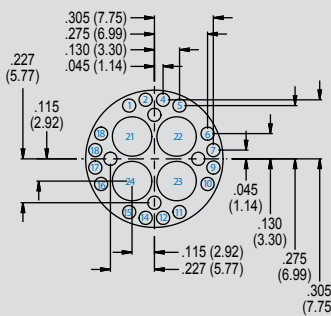

SUBSEA SHALLOW WATER: AQUAMOUSE™



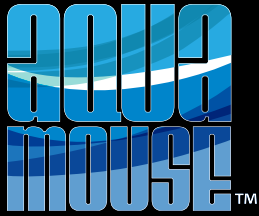

SERIES 802 2400M / 3500 PSI Ultraminiature Subsea Connectors



Hybrid PCB footprints
Viewed from component mounting side of PCB

Contact Arrangement

Pin Connector

Socket Connector

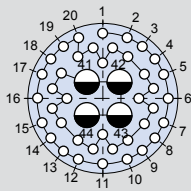

**Contact Arrangement
15-203**

- 4 #16 Contacts
- .064 (1.63) Max. Dia. Tail
- 40 #23 Contacts
- .022 (0.71) Max. Dia. Tail

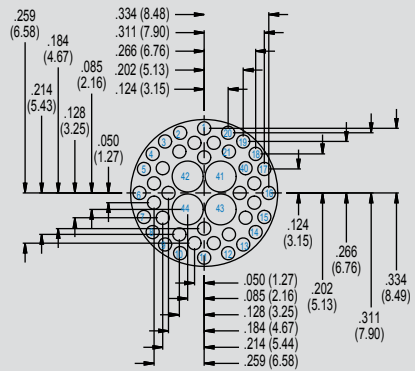
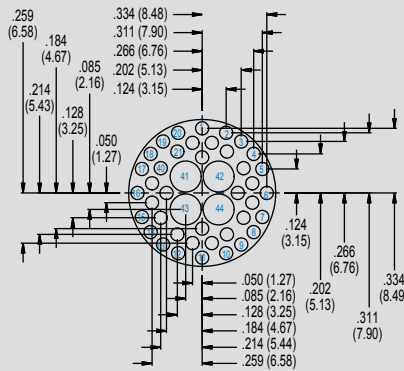

SUBSEA/SHALLOW WATER: AQUAMOUSE™

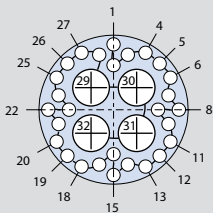

**Contact Arrangement
15-204**

- 4 #12 Contacts
- .096 (2.44) Max. Dia. Tail
- 28 #23 Contacts
- .022 (0.71) Max. Dia. Tail

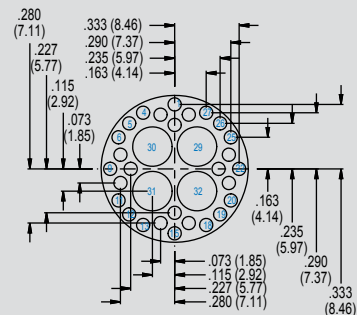
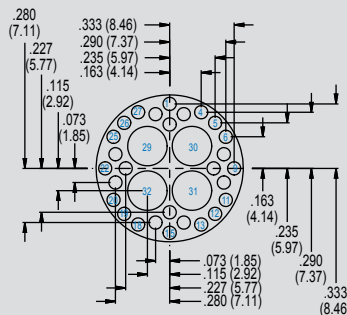

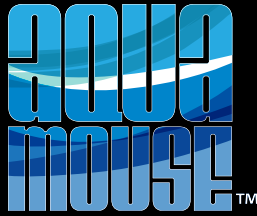

SERIES 802 2400M / 3500 PSI Ultraminiature Subsea Connectors



Hybrid PCB footprints
Viewed from component mounting side of PCB

Contact Arrangement

Pin Connector

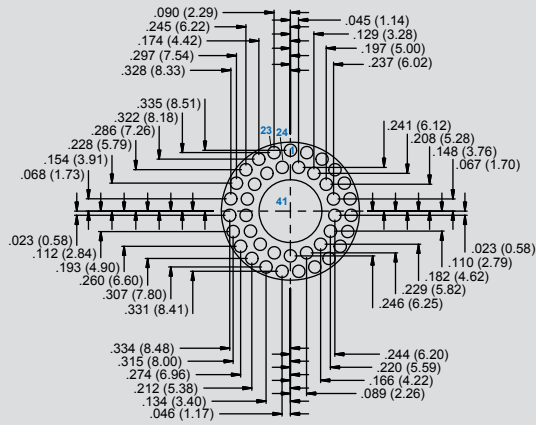
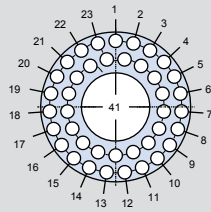

Socket Connector

Contact Arrangement

15-205

1 #8 Contacts

.182 (4.62) Max. Dia. Tail

40 #23 Contacts

.022 (0.56) Max. Dia. Tail

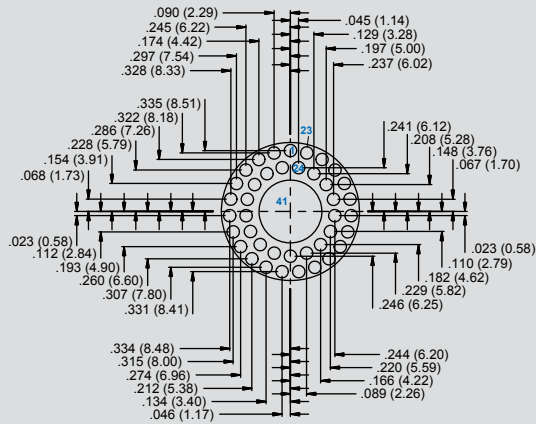

SUBSEA SHALLOW WATER: AQUAMOUSE™



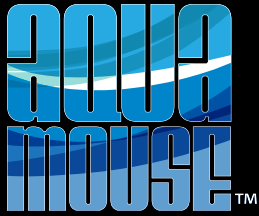

SERIES 802 2400M / 3500 PSI
Ultraminiature Subsea Connectors



Hybrid PCB footprints
 Viewed from component mounting side of PCB

Contact Arrangement

Pin Connector

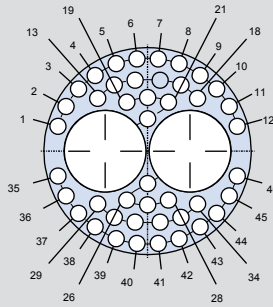

Contact Arrangement 19-201
 2 #8 Contacts
 .182 (4.62) Max. Dia. Tail
 44 #23 Contacts
 .022 (.56) Max. Dia. Tail

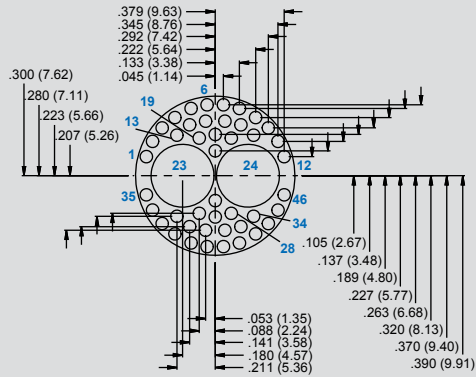

Socket Connector

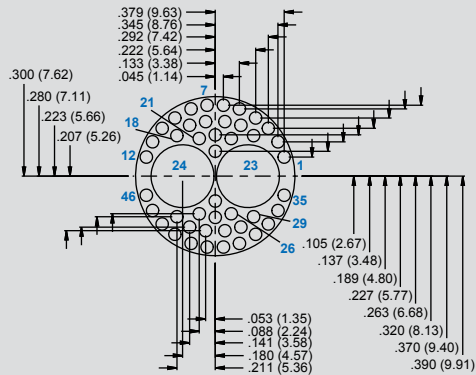

SUBSEA/SHALLOW WATER: AQUAMOUSE™



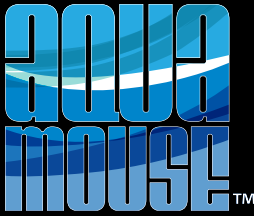

SERIES 802 2400M / 3500 PSI Ultraminiature Subsea Connectors



Hybrid PCB footprints
Viewed from component mounting side of PCB

Contact Arrangement	Pin Connector	Socket Connector
---------------------	---------------	------------------

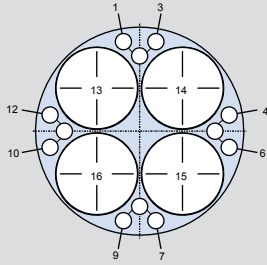

**Contact Arrangement
19-202**

4 #8 Contacts
.182 (4.62) Max. Dia. Tail
12 #23 Contacts
.022 (.56) Max. Dia. Tail

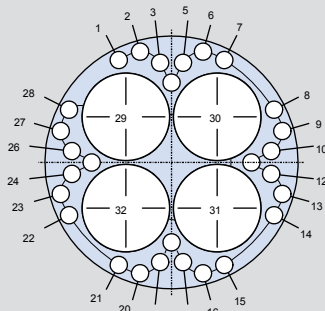
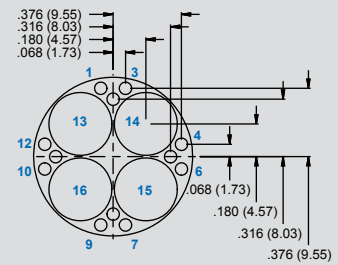
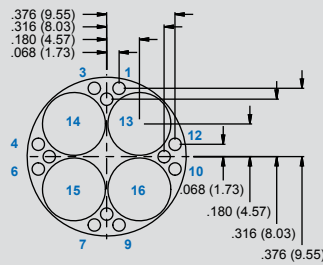

**Contact Arrangement
21-200**

4 #8 Contacts
.182 (4.62) Max. Dia. Tail
28 #23 Contacts
.022 (0.56) Max. Dia. Tail

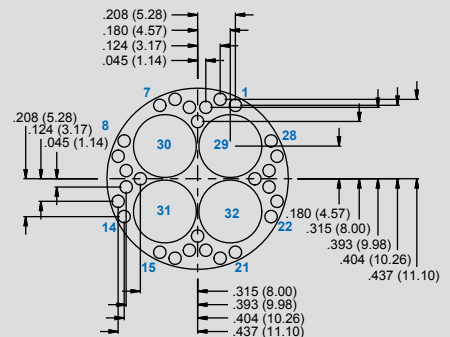
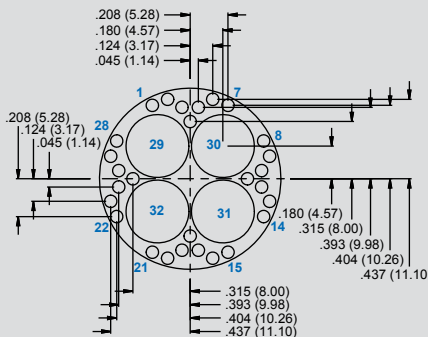

SUBSEA SHALLOW WATER: AQUAMOUSE™

