

SERIES 802 2400M / 3500 PSI Ultraminiature Subsea Connectors



802-013 submersible hermetic PC tail or solder cup receptacles



Series 802 Hermetic Receptacles feature gold plated iron alloy contacts and compression glass dielectric material. The 316 series stainless steel connector shell provides excellent corrosion protection and is suitable for e-beam welding. Viton® o-rings offer improved resistance to high temperature and harsh chemicals.

1 x 10⁻⁷ cc/Second Maximum Helium Leak Rate. Open face (unmated) pressure rating is 1000 PSI. When mated, Series 802 connectors withstand 3500 PSI hydrostatic pressure.

SUBSEA/SHALLOW WATER: AQUAMOUSE™

How To Order						
Sample Part Number	802-013	-00	Z1	9-200	P	A
Series	802-013 = Hermetic Receptacle					
Shell Style (See Table I)	-00 = Jam Nut for Front Panel Mounting -02 = Square Flange Front Panel Mount		-03 = Weld Mount -07 = Jam Nut Rear Panel Mount			
Shell Material and Finish	Z1 = Stainless Steel / Passivated RoHS Compliant ZL = Stainless Steel / Nickel Plated					
Shell Size - Contact Arrangement	See Contact Arrangements pages 4 - 6					
Contact Type	P = Pin, PC Tail E = Pin, Solder Cup		D = Socket, PC Tail S = Socket, Solder Cup			
Shell Key Position (See Table II)	A = Normal B = Pos. B C = Pos. C D = Pos. D E = Pos. E F = Pos. F					

Table I: Shell Style			
-00 Jam Nut for Front Panel Mounting	-02 Square Flange	-03 Weld Mount	-07 Jam Nut for Rear Panel Mounting

Table II: Keyway Positions		
Key Position	Key Rotation	
	A°	B°
A Normal	150°	210°
B	75°	210°
C	95°	230°
D	140°	275°
E	75°	275°
F	9°	210°

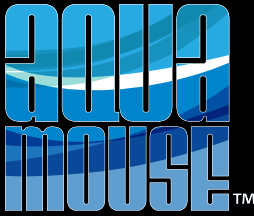

SERIES 802 2400M / 3500 PSI
Ultraminiature Subsea Connectors
 802-013-00 submersible hermetic
 Front panel mount, jam nut receptacle



FRONT PANEL MOUNT, SOLDER CUP OR PC TAIL JAM NUT RECEPTACLE - SHELL STYLE 00

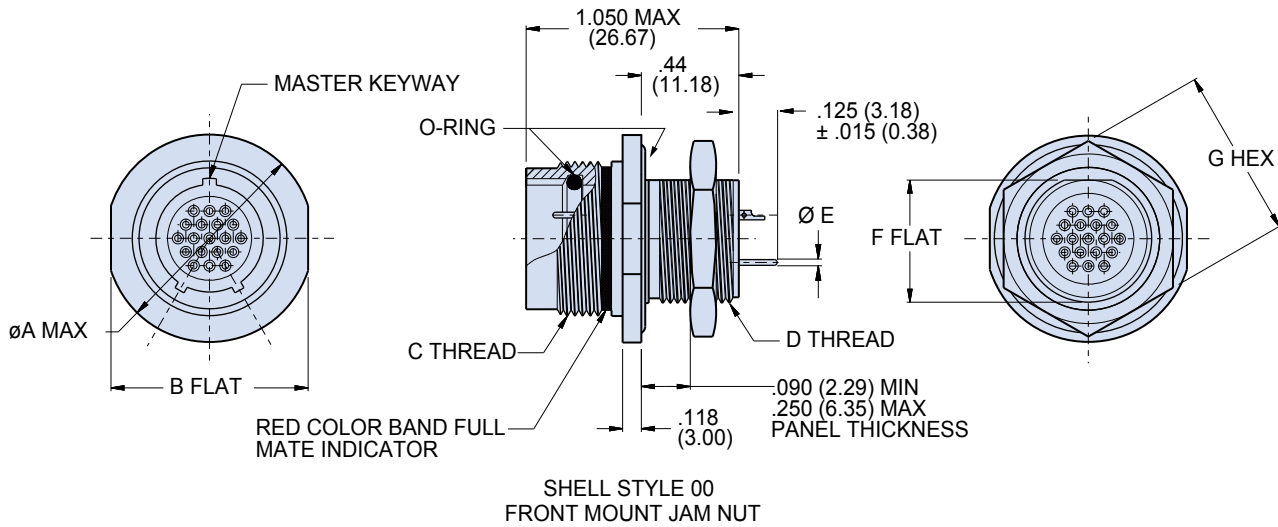

Shell Size	Dimensions					Panel Cutout			
	Ø A Max.	B Flat	C Threads	D Threads	Ø E Tail Dia.	F Flat	G Hex	H Flat	Ø J
5	.72 (18.29)	.625 (15.88)	.4375-28 UNEF-2A	.312-28 UN-2A	#23 .018/.022 (0.46/0.56) #20 .024/.028 (0.61/0.71) #16 .060/.064 (1.52/1.63) #12 .092/.096 (2.34/2.44)	.281 (7.14)	.500 (12.70)	.291 (.739) .286 (7.26)	.322 (8.18)
6	.78 (19.81)	.750 (19.05)	.5625-20 UN-2A	.438-28 UN-2A		.406 (10.31)	.625 (15.88)	.417 (10.59) .412 (10.46)	.448 (11.38)
7	.91 (23.11)	.812 (20.62)	.6250-20 UN-2A	.500-32 UN-2A		.469 (11.91)	.688 (17.48)	.479 (12.17) .474 (12.04)	.510 (12.95)
8	.96 (24.38)	.875 (22.23)	.6875-20 UN-2A	.562-28 UN-2A		.531 (13.49)	.750 (19.05)	.541 (13.74) .536 (13.61)	.572 (14.53)
9	1.03 (26.16)	.937 (23.80)	.7500-20 UNEF-2A	.625-20 UN-2A		.594 (15.09)	.812 (20.62)	.604 (15.34) .599 (15.21)	.635 (16.13)
10	1.09 (27.69)	1.000 (25.40)	.8125-20 UNEF-2A	.687-28 UN-2A		.656 (16.66)	.875 (22.23)	.666 (16.92) .661 (16.79)	.697 (17.70)
12	1.16 (29.46)	1.062 (26.97)	.8750-20 UNEF-2A	.750-28 UN-2A		.719 (18.26)	.938 (23.83)	.729 (18.52) .724 (18.39)	.760 (19.30)
14	1.34 (34.04)	1.250 (31.75)	1.0625-20 UN-2A	.938-28 UN-2A		.893 (22.68)	1.125 (28.58)	.903 (22.94) .898 (22.81)	.948 (24.08)
15	1.41 (35.81)	1.312 (33.32)	1.1250-20 UN-2A	1.000-28 UN-2A		.955 (24.26)	1.188 (30.18)	.965 (24.51) .960 (24.38)	1.010 (25.65)
21	1.70 (43.18)	1.562 (39.67)	1.4375-20 UN-2A	1.312-28 UN-2A		1.257 (31.93)	1.500 (38.10)	1.267 (32.18) 1.263 (32.08)	1.322 (33.58)

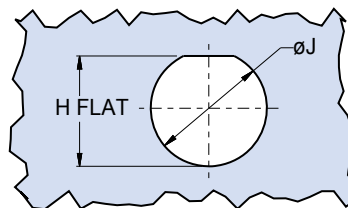

RECOMMENDED PANEL CUTOUT
 FOR STYLE 00
 FRONT MOUNT JAM NUT

SUBSEA SHALLOW WATER: AQUAMOUSE™



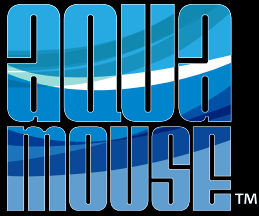

SERIES 802 2400M / 3500 PSI
Ultraminiature Subsea Connectors



802-013-07 submersible hermetic
 Rear panel mount, jam nut receptacle

REAR PANEL MOUNT, SOLDER CUP OR PC TAIL JAM NUT RECEPTACLE - SHELL STYLE 07

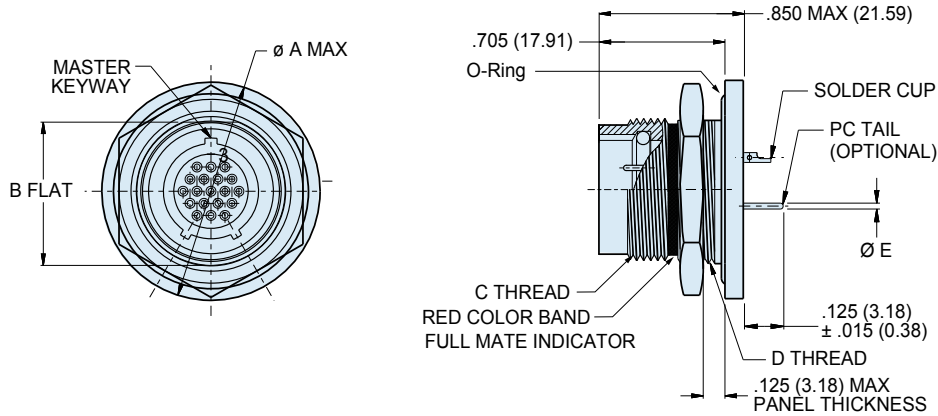

SHELL STYLE 07
 REAR MOUNT JAM NUT

SUBSEA/SHALLOW WATER: AQUAMOUSE™

Dimensions								
Shell Size	A Max.	B Flat ± .003 (.08)	C Threads	D Threads	Ø E Tail Dia.	F Flat ± .003 (.08)	Ø G	
5	.885 (22.48)	.466 (11.84)	.438-28 UNEF	.500-32 UN-2A	#23 .018/.022 (0.46/0.56)	.479 (12.17) .474 (12.04)	.510 (12.95)	
6	1.010 (25.65)	.591 (15.01)	.562-20 UN	.625-20 UN-2A		.604 (15.34) .599 (15.21)	.635 (16.13)	
7	1.072 (27.23)	.653 (16.59)	.625-20 UN	.687-28 UN-2A		.666 (16.92) .661 (16.79)	.697 (17.70)	
8	1.135 (28.83)	.729 (18.52) .725 (18.42)	.687-20 UN	.750-28 UN-2A		.737 (18.72) .733 (18.62)	.760 (19.30)	
9	1.195 (30.35)	.778 (19.76)	.750-20 UNEF	.812-28 UN-2A		#20 .024/.028 (0.61/0.71)	.791 (20.09) .786 (19.96)	.822 (20.88)
10	1.260 (32.00)	.827 (21.01)	.812-20 UNEF	.875-28 UN-2A			#16 .060/.064 (1.52/1.63)	.840 (21.34) .835 (21.21)
12	1.322 (33.58)	.890 (22.61)	.875-20 UNEF	.938-28 UN-2A		#12 .092/.096 (2.34/2.44)		.903 (22.94) .898 (22.81)
14	1.510 (38.35)	1.077 (27.36)	1.062-20 UN	1.125-28 UN-2A			1.090 (27.69) 1.085 (27.56)	1.135 (28.83)
15	1.572 (39.93)	1.140 (28.96)	1.125-20 UN	1.188-28 UN-2A			1.153 (29.29) 1.148 (29.16)	1.198 (30.43)
21	1.940 (49.28)	1.467 (37.26) 1.463 (37.16)	1.4375-20 UN	1.500-28 UN-2A		1.475 (37.47) 1.471 (37.36)	1.510 (38.35)	

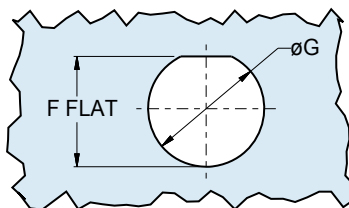

RECOMMENDED PANEL CUTOUT
 FOR STYLE 07 REAR MOUNT JAM NUT

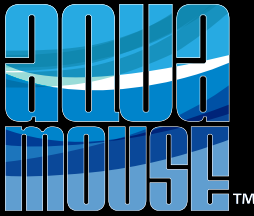

SERIES 802 2400M / 3500 PSI
Ultraminiature Subsea Connectors
 802-013-03 submersible hermetic
 Weld mount receptacle



WELD MOUNT, SOLDER CUP OR PC TAIL RECEPTACLE - SHELL STYLE 03

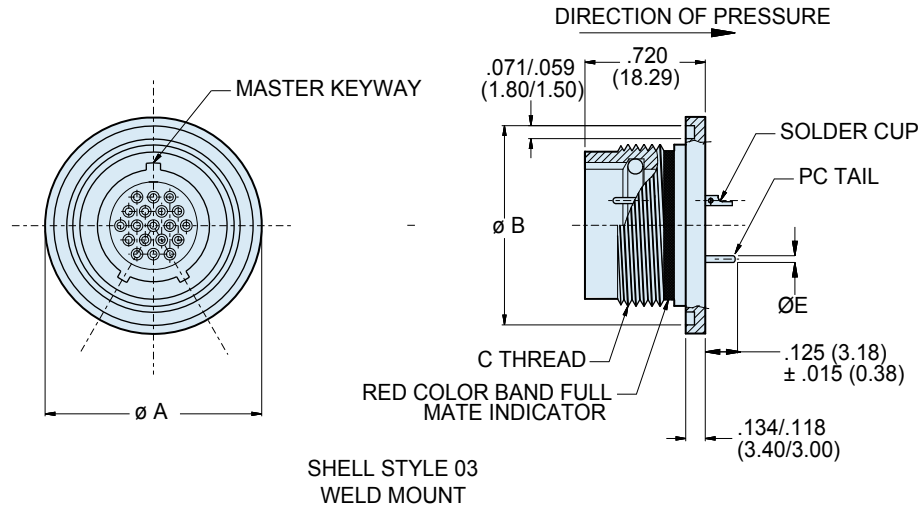

Dimensions				
Shell Size	Ø A ± .006 (.15)	Ø B ± .006 (.15)	C Mating Threads	Ø E Tail Dia.
5	.788 (20.02)	.745 (18.92)	.438-28 UNEF	#23 .018/.022 (0.46/0.56)
6	.912 (23.16)	.869 (22.07)	.562-20 UN	
7	.975 (24.76)	.933 (23.70)	.625-20 UN	
8	1.038 (26.37)	.995 (25.27)	.687-20 UN	#20 .024/.028 (0.61/0.71)
9	1.100 (27.94)	1.057 (26.85)	.750-20 UNEF	
10	1.162 (29.51)	1.119 (28.42)	.812-20 UNEF	#16 .060/.064 (1.52/1.63)
12	1.225 (31.12)	1.182 (30.02)	.875-20 UNEF	
14	1.412 (35.86)	1.369 (34.77)	1.062-20 UN	
15	1.475 (37.47)	1.432 (36.37)	1.125-20 UN	#12 .092/.096 (2.34/2.44)
21	1.795 (45.59)	1.750 (44.45) 1.744 (44.30)	1.4375-20 UN	

SUBSEA SHALLOW WATER: AQUAMOUSE™



802-013-02 submersible hermetic receptacle
 flange connector receptacle (FCR)

SOLDER CUP OR PC TAIL FRONT PANEL MOUNT RECEPTACLE - SHELL STYLE 02

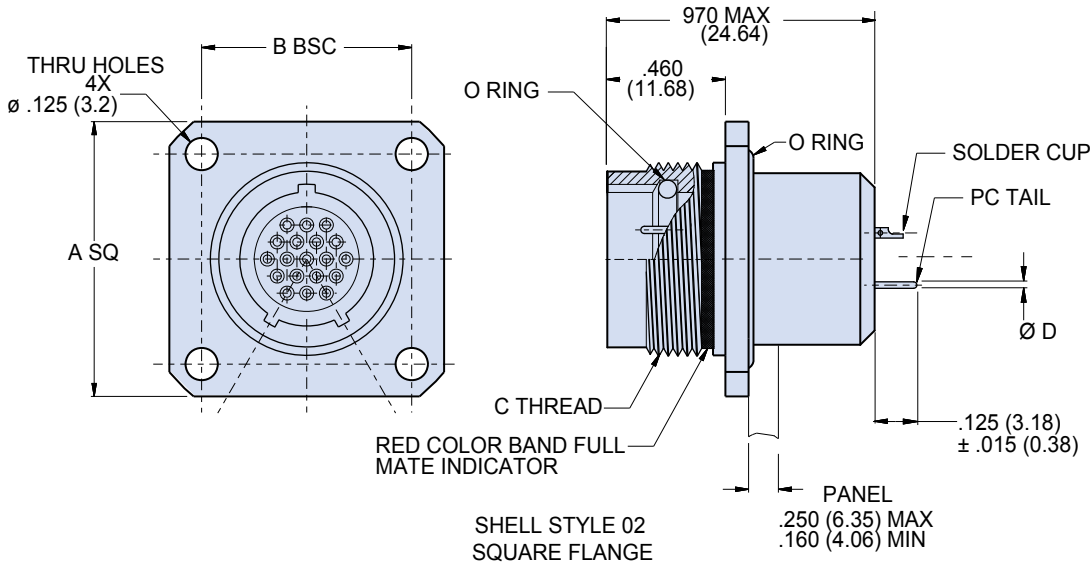

Dimensions					
Shell Size	A Square	B Bsc.	C Mating Threads	Ø D Tail Dia.	Ø E
5	.885 (22.48)	.500 (12.70)	.438-28 UNEF	#23 .018/.022 (0.46/0.56)	.327 (8.31)
6	1.010 (25.65)	.625 (15.88)	.562-20 UN		.390 (9.91)
7	1.072 (27.23)	.688 (17.48)	.625-20 UN		.515 (13.08)
8	1.135 (28.83)	.750 (19.05)	.687-20 UN	#20 .024/.028 (0.61/0.71)	.577 (14.66)
9	1.195 (30.35)	.812 (20.62)	.750-20 UNEF		.640 (16.26)
10	1.260 (32.00)	.875 (22.23)	.812-20 UNEF	#16 .060/.064 (1.52/1.63)	.702 (17.83)
12	1.323 (33.60)	.938 (23.83)	.875-20 UNEF		.765 (19.43)
14	1.510 (38.35)	1.125 (28.58)	1.062-20 UN		.953 (24.21)
15	1.573 (39.95)	1.188 (30.18)	1.125-20 UN	#12 .092/.096 (2.34/2.44)	1.015 (25.78)
21	1.750 (44.45)	1.375 (34.92)	1.4375-20 UN		1.312 (33.32)

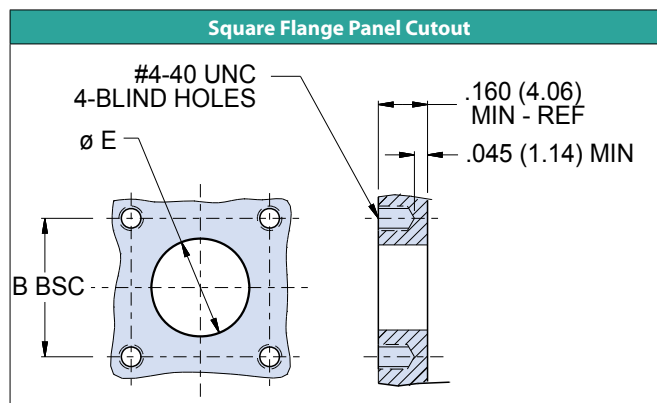

SUBSEA/SHALLOW WATER: AQUAMOUSE™