

# SERIES 802 2400M / 3500 PSI Ultraminiature Subsea Connectors



## 802-010 and 802-011 Submersible receptacle



**Jam Nut, Rear Mount**

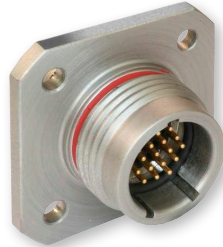

**FCR Flange Connector Receptacle (Square Flange)**

**Three Shell Mounting Options:** Jam nut with o-ring for rear panel mounting, flange connector receptacle for front panel mounting, or in-line receptacles for free-hanging cables.

**Two Shell Styles:** Choose the integral band platform for direct attachment of a cable shield. Install a boot, or overmold a boot over the band platform. An accessory thread is available for attaching strain reliefs and backshells.

SUBSEA/SHALLOW WATER: AQUAMOUSE™

How To Order							
<b>Sample Part Number</b>		<b>802-011</b>	<b>-02</b>	<b>Z1</b>	<b>10-26</b>	<b>P</b>	<b>B</b>
<b>Series (See Table I)</b>	<b>802-010</b> = Receptacle with Banding Platform <b>802-011</b> = Receptacle with Accessory Thread						
<b>Shell Style (See Table II)</b>	<b>-01</b> = In-Line <b>-02</b> = Flange Connector Receptacle <b>-07</b> = Jam Nut for Rear Panel Mounting						
<b>Shell Material and Finish</b>	<b>Z1</b> = Stainless Steel/Passivated RoHS Compliant <b>ZM</b> = Stainless Steel/Electroless Nickel Plated <b>AB</b> = Marine Bronze/Unplated						
<b>Shell Size - Contact Arrangement</b>	See Contact Arrangements page 4-6						
<b>Contact Type</b>	<b>Connector supplied with contacts</b> <b>P</b> = Pin, Crimp <b>S</b> = Socket, Crimp Connectors with contacts are supplied with signal and/or power crimp contacts. These contacts are not installed. Coaxial contacts and non-standard signal contacts are ordered separately.		<b>Connector supplied without contacts</b> <b>A</b> = Pin Connector, less contacts <b>B</b> = Socket Connector, less contacts				
<b>Shell Key Positions (See Table III)</b>	<b>A</b> = Normal <b>B</b> = Pos. B <b>C</b> = Pos. C <b>D</b> = Pos. D <b>E</b> = Pos. E <b>F</b> = Pos. F See Keyway Positions Table						

Table I: Series	
<b>802-010</b> Receptacle with Banding Platform	<b>802-011</b> Receptacle with Accessory Thread

Table II: Shell Style		
<b>-01</b> In-Line	<b>-02</b> Square Flange	<b>-07</b> Jam Nut for Rear Panel Mounting

Keyway Positions		
Position	A°	B°
A	150°	210°
B	75°	210°
C	95°	230°
D	140°	275°
E	75°	275°
F	95°	210°

Rev. 10/23/17

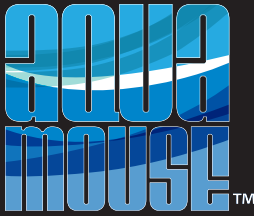

# SERIES 802 2400M / 3500 PSI Ultraminiature Subsea Connectors



## 802-010 and 802-011 Rear panel mount, jam nut receptacle

### JAM NUT, REAR PANEL MOUNT RECEPTACLE - SHELL STYLE 07

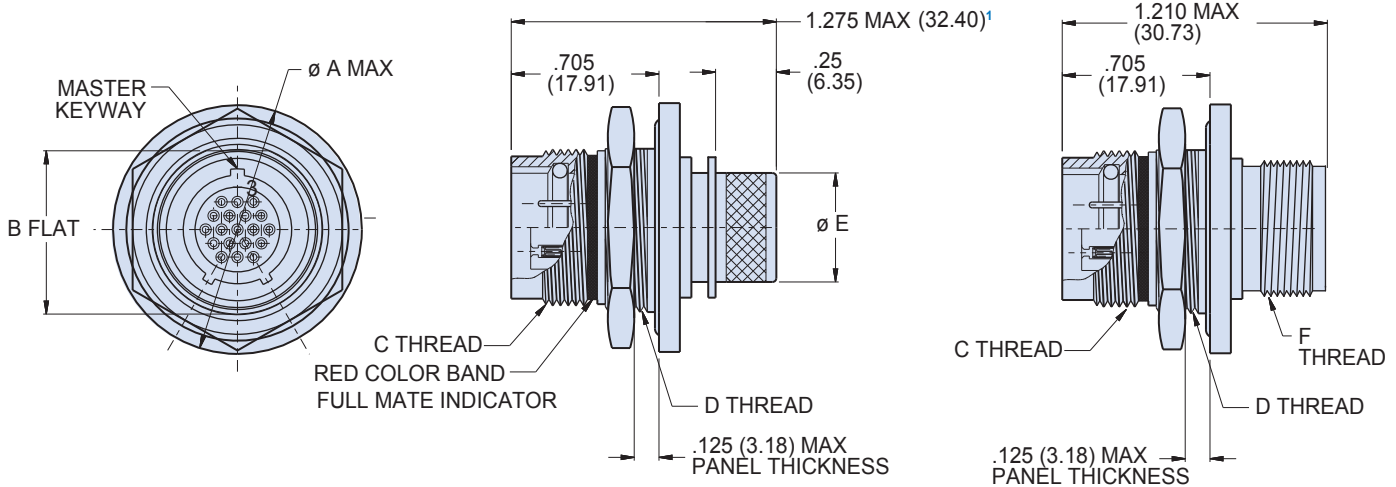

Intergral Band Platform  
**802-010**

Accessory Thread  
**802-011**

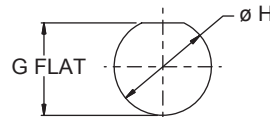

RECOMMENDED PANEL CUT OUT  
STYLE 07

#### NOTES

1. Grommet protrudes for power/ combo/#8 arrangements.

Shell Size	Dimensions					Panel Cutout Dimensions		
	A Max.	B Flat ± .003	C Mating Threads	D Jam Nut Threads	Ø E	F Accessory Threads	G Flat ± .003	Ø H
5	.885 (22.48)	.466 (11.84)	.4375-28 UNEF	.5000-32 UN-2A	.232 (5.89)	.2500-32 UNEF-2A	0.479 (12.17) 0.474 (12.04)	.510 (12.95)
6	1.010 (25.65)	.591 (15.01)	.5625-20 UN	.6250-28 UN-2A	.312 (7.92)	.3125-32 UNEF-2A	0.604 (15.34) 0.599 (15.21)	.635 (16.13)
7	1.072 (27.23)	.653 (16.59)	.6250-20 UN	.6875-28 UN-2A	.375 (9.52)	.4375-28 UNEF-2A	0.666 (16.92) 0.661 (16.79)	.697 (17.70)
8	1.135 (28.83)	.729/.725 (18.52/18.41)	.6875-20 UN	.7500-28 UN-2A	.438 (11.13)	.5000-28 UNEF-2A	0.737 (18.72) 0.733 (18.62)	.760 (19.30)
9	1.195 (30.35)	.778 (19.76)	.7500-20 UNEF	.8125-28 UN-2A	.500 (12.70)	.5625-24 UNEF-2A	0.791 (20.09) 0.786 (19.96)	.822 (20.88)
10	1.260 (32.00)	.827 (21.01)	.8125-20 UNEF	.8750-28 UN-2A	.562 (14.27)	.6250-24 UNEF-2A	0.84 (21.34) 0.835 (21.21)	.885 (22.48)
12	1.322 (33.58)	.890 (22.61)	.8750-20 UNEF	.9375-28 UN-2A	.656 (16.66)	.6875-24 UNEF-2A	0.903 (22.94) 0.898 (22.81)	.948 (24.08)
14	1.510 (38.35)	1.077 (27.36)	1.0625-20 UN	1.1250-28 UN-2A	.812 (20.62)	.8750-20 UNEF-2A	1.09 (27.69) 1.085 (27.56)	1.135 (28.83)
15	1.572 (39.93)	1.140 (28.96)	1.1250-20 UN	1.1875-28 UN-2A	.885 (22.48)	.9375-20 UNEF-2A	1.153 (29.29) 1.148 (29.16)	1.198 (30.43)
21	1.940 (49.28)	1.467/1.463 (37.26/ 37.16)	1.4375-20 UN	1.5000-28 UN-2A	1.188 (30.18)	1.2500-20 UNEF-2A	1.478 (37.54) 1.471 (37.36)	1.510 (38.35)



**FLANGE CONNECTOR RECEPTACLE, FRONT PANEL MOUNT - SHELL STYLE 02**

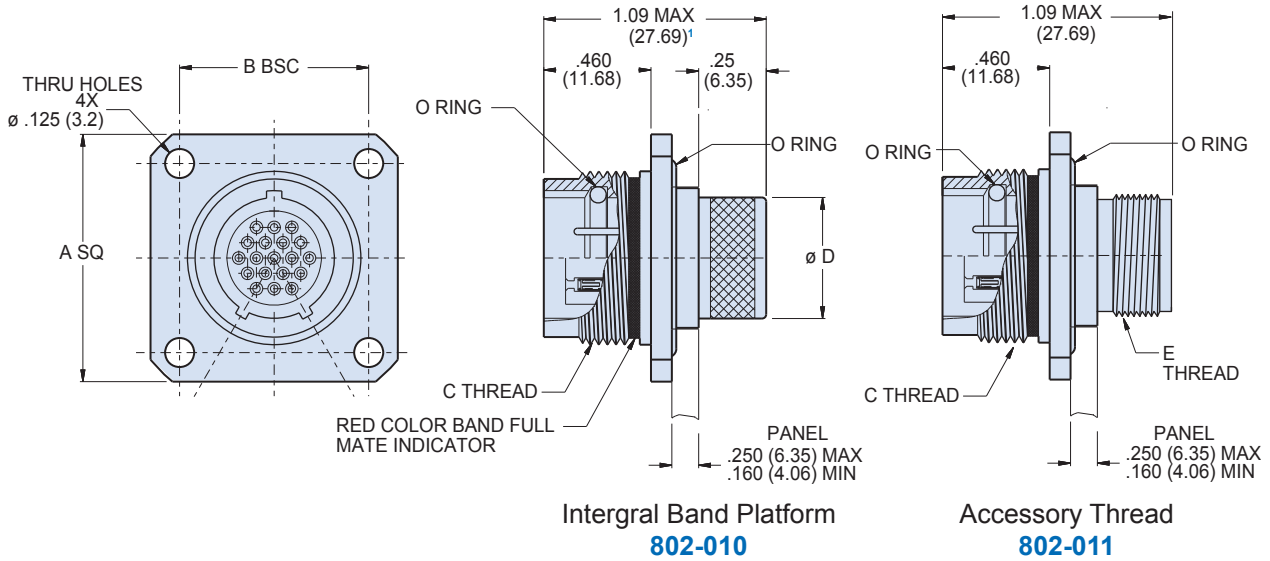

SUBSEA/SHALLOW WATER: AQUAMOUSE™

Dimensions						
Shell Size	A Square	B Bsc.	C Mating Threads	Ø D	E Accessory Threads	Ø F
5	.885 (22.48)	.500 (12.70)	.4375-28 UNEF	.232 (5.89)	.250-32 UNEF-2A	.327 (8.31)
6	1.010 (25.65)	.625 (15.88)	.5625-20 UN	.312 (7.92)	.312-32 UNEF-2A	.390 (9.91)
7	1.072 (27.23)	.688 (17.48)	.6250-20 UN	.375 (9.52)	.438-28 UNEF-2A	.515 (13.08)
8	1.135 (28.83)	.750 (19.05)	.6875-20 UN	.438 (11.13)	.500-28 UNEF-2A	.577 (14.66)
9	1.195 (30.35)	.812 (20.62)	.7500-20 UNEF	.500 (12.70)	.562-24 UNEF-2A	.640 (16.26)
10	1.260 (32.00)	.875 (22.23)	.8125-20 UNEF	.562 (14.27)	.625-24 UNEF-2A	.702 (17.83)
12	1.323 (33.60)	.938 (23.83)	.8750-20 UNEF	.656 (16.66)	.688-24 UNEF-2A	.765 (19.43)
14	1.510 (38.35)	1.125 (28.58)	1.0625-20 UN	.812 (20.62)	.875-20 UNEF-2A	.953 (24.21)
15	1.573 (39.95)	1.188 (30.18)	1.1250-20 UN	.885 (22.48)	.938-20 UNEF-2A	1.015 (25.78)
21	1.750 (44.45)	1.375 (34.92)	1.4375-20 UN	1.188 (30.18)	1.250-20 UNEF-2A	1.312 (33.32)

Piston O-ring replacement	
Shell size	Flange Style 02 O-ring P/N
5	2-012
6	2-014
7	2-015
8	2-016
9	2-017
10	2-018
12	2-019
14	2-022
15	2-023
21	2-028

**NOTES**

- Grommet protrudes for power/ combo/#8 arrangements.

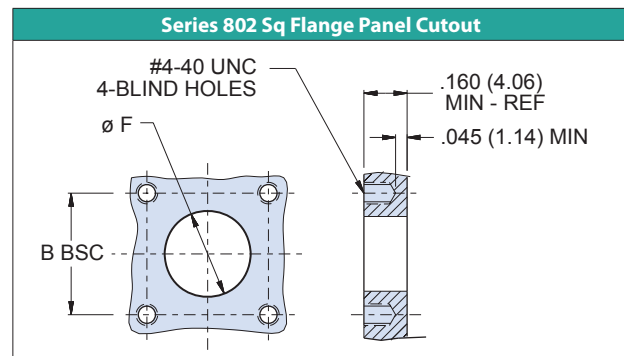

**CABLE CONNECTOR RECEPTACLE, INLINE - SHELL STYLE 01**

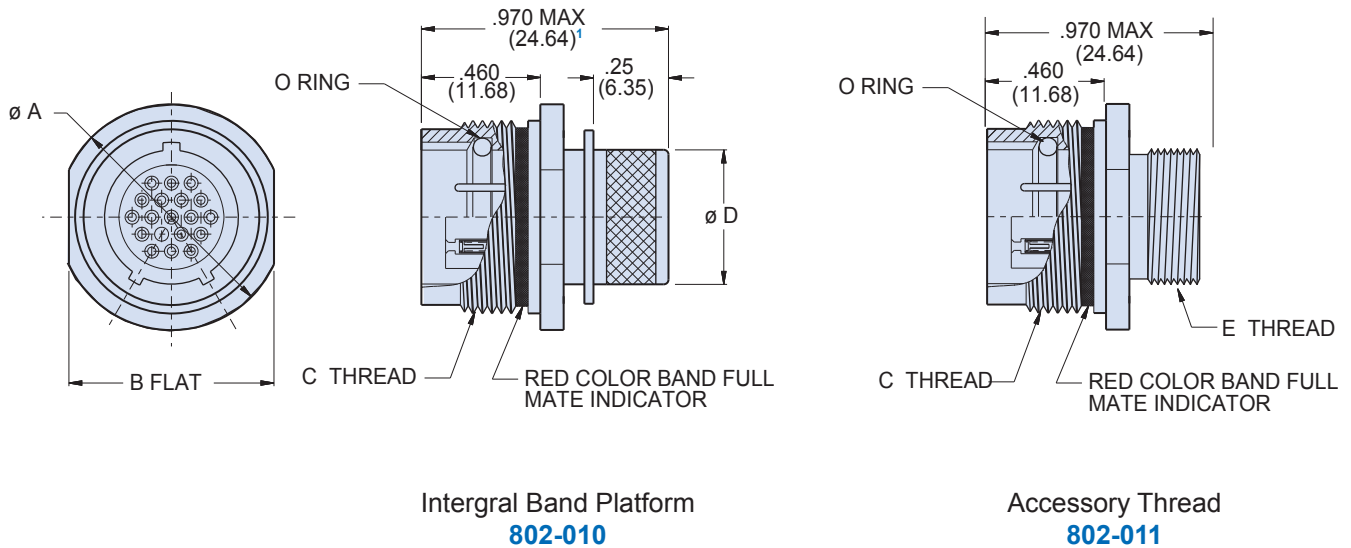

Integral Band Platform  
**802-010**

Accessory Thread  
**802-011**

Dimensions					
Shell Size	Ø A	B Flats	C Mating Threads	Ø D	E Accessory Threads
5	.560 (14.22)	.500 (12.70)	.4375-28 UNEF	.232 (5.89)	.250-32 UNEF-2A
6	.720 (18.29)	.625 (15.88)	.5625-20 UN	.312 (7.92)	.312-32 UNEF-2A
7	.780 (19.81)	.688 (17.48)	.6250-20 UN	.375 (9.52)	.438-28 UNEF-2A
8	.860 (21.84)	.750 (19.05)	.6875-20 UN	.438 (11.13)	.500-28 UNEF-2A
9	.930 (23.62)	.812 (20.62)	.7500-20 UNEF	.500 (12.70)	.562-24 UNEF-2A
10	1.000 (25.40)	.875 (22.23)	.8125-20 UNEF	.562 (14.27)	.625-24 UNEF-2A
12	1.060 (26.92)	.938 (23.83)	.8750-20 UNEF	.656 (16.66)	.688-24 UNEF-2A
14	1.250 (31.75)	1.125 (28.58)	1.0625-20 UN	.812 (20.62)	.875-20 UNEF-2A
15	1.320 (33.53)	1.188 (30.18)	1.1250-20 UN	.885 (22.48)	.938-20 UNEF-2A
21	1.690 (42.93)	1.562 (39.67)	1.4375-20 UN	1.188 (30.18)	1.250-20 UNEF-2A

Piston O-ring replacement	
Shell size	Piston O-ring P/N
5	2-009
6	5-052
7	5-012
8	5-212
9	2-014
10	2-015
12	2-016
14	2-019
15	2-020
21	2-023

**NOTES**

1. Grommet protrudes for power/ combo/#8 arrangements.

