

602-002 Digital Torque Wrench

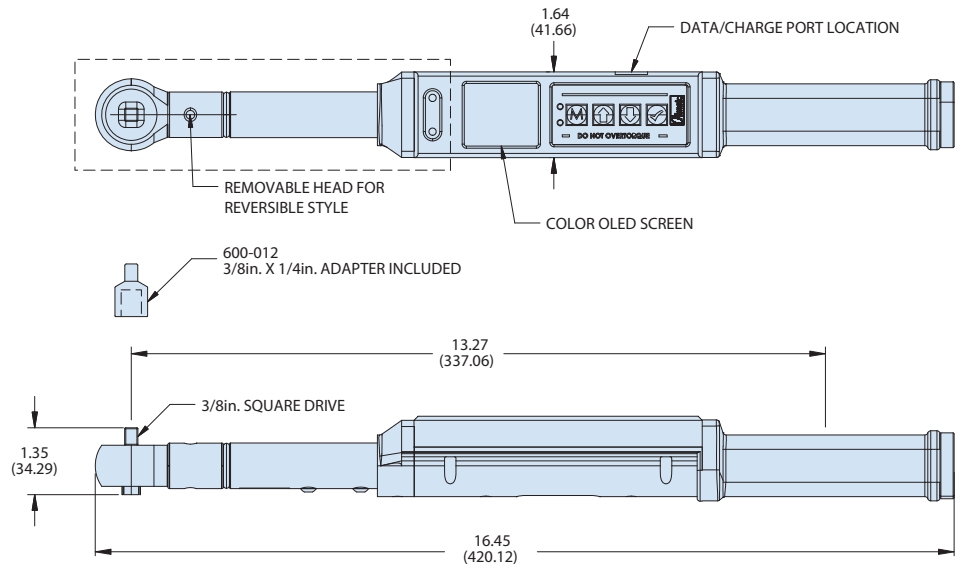

HOW TO ORDER	
Sample Part Number	602-002
Basic Part Number	602-002 Digital Torque Wrench Reversible Head



NOTES

- Assembly identified with manufacturer's name and part number.
- Use in conjunction with Glenair connector and backshell tools.
- Torque range: 17.7-177 In/lbs; digital graduations 1/10 in/lb; accuracy: $\pm 1\%$ of indicated value.
- AAA rechargeable batteries and 3/8in. to 1/4in. Drive adapter included, weight: 2.1 Lb.
- Torque arm length provided for offset torque calculation.
- Keeper pin in the tool head must be pressed in with a small tool to release, remove, and reverse the head.
- To purchase bench mount: order number 602-003, horizontal mount (flat).
- Data tracking software available upon request.
- Calibration certificate included. Recommended to be calibrated annually.