

	Issue date	22/06/21
	Test Report	
	TR	170-21
	Pag. 1 of 36	Rev. 0

Test Laboratory Glenair Italia S.p.a.
Via del Lavoro 7, Quarto Inferiore – Granarolo dell’Emilia (BO) 40057, Italy

Client - cliente: Glenair Italia – Product Manager

Reference contact – contatto: P. Brulatti

Title – titolo:
Octobyte - Ethernet Test – Cat. 8

Tests carried out by - test eseguito da: S. Cremonini	
Test report compiled by - rapporto di prova scritto da: S. Cremonini	

Statement - dichiarazione: *This is to certify that all tests have been conducted in accordance with the order/ specification / test programme. The results relate to the samples tested and have been accurately recorded in the test report given under the Testlab Manager authority. This report shall not be reproduced without the written approval of the laboratory- Questo per dichiarare che tutte le prove sono state effettuate in accordo agli ordini / norme / programmi di prova. I risultati sono relativi ai campioni sottoposti alle prove sono stati registrati in maniera accurata nel rapporto di prova distribuito sotto la supervisione del Responsabile del Laboratorio. Questo rapporto di prova non deve essere riprodotto senza il consenso scritto del Laboratorio.*

Test report approved by – rapporto di prova approvato da: L. Marani	
--------------------------------------------------------------------------------------	---------------------------------------------------------------------------------------

Test Laboratory Glenair Italia s.p.a.
 Tel. +39 051 6069998
 Email: labs@glenair.it

	Issue date	22/06/21
	Test Report	
	TR	170-21
	Pag. 2 of 36	Rev. 0

Summary page – pagina riassuntiva:

a) Scope of test – scopo delle prove

The purpose was to carry out an Ethernet Cat 8 test on new Octobyte connectors. Ethernet TIA/EIA 568 CAT 8 and ISO11801 Class II allows to transmits/receive at 40GBASE-T (40 Gigabit Ethernet) for transmitting Ethernet frames at rates of 40 gigabits per second (Gbit/s).

Ethernet test can be performed as Channel link or Permanent link performance. Permanent link requirements are more severe than channel requirement.

Test was performed with Permanent Link requirements to test the more severe requirement.

Test configuration:

Only cable (as reference)

- Socket Tera connector – 24 meter of cable – Socket Tera connector.

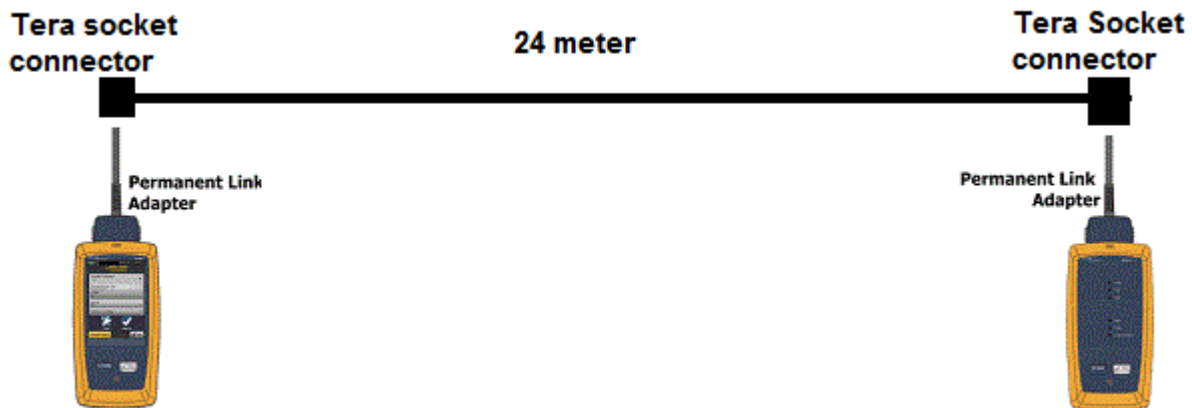



Test Report

TR

170-21

1 Octobyte connection:

- Socket Tera connector – 12 meter of cable – Octobyte socket connector **mated with** Octobyte Plug connector – 12 meter of cable - Socket Tera connector.

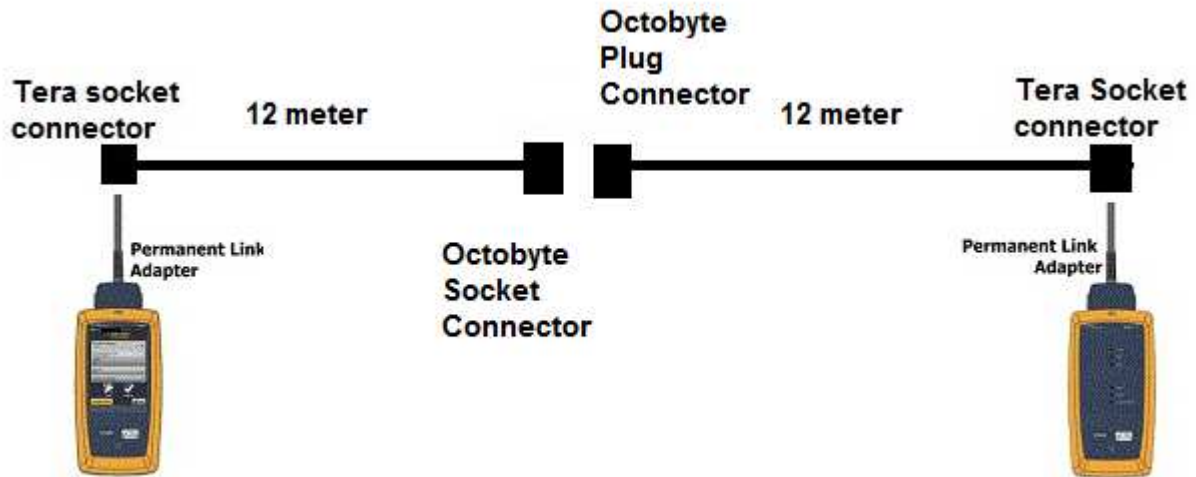

2 Octobyte connections:

- Socket Tera connector – 12 meter of cable – Octobyte socket connector **mated with** Octobyte Plug connector – 2,5 meter of cable – Octobyte Plug connector **mated with** Octobyte Socket connector – 9,5 meter of cable - Socket Tera connector.

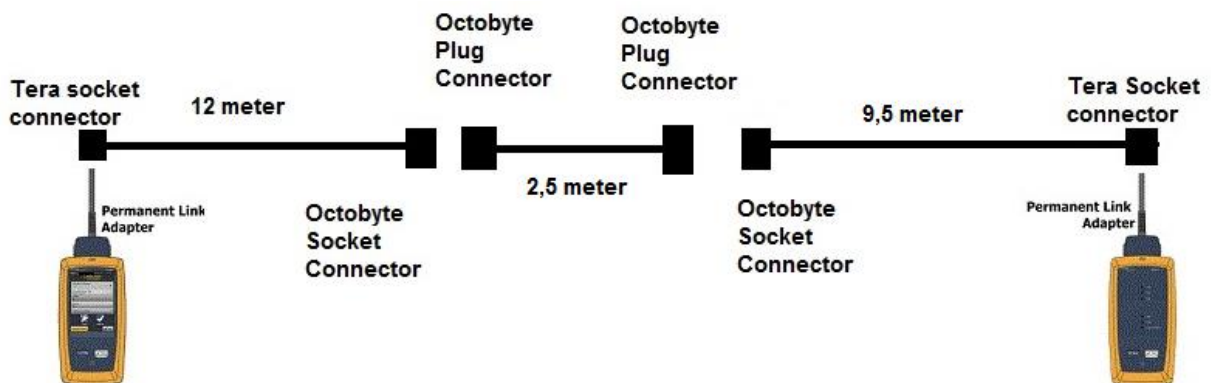

	Issue date	22/06/21
	Test Report	
	TR	170-21
	Pag. 4 of 36	Rev. 0

b) Conclusions / Outcome – conclusioni / esito:

Test	Only Cable	1 Octobyte connection	2 Octobyte connections
TIA/EIA 568 CAT 8 Permanent Link	PASS	PASS	PASS
ISO11801 Class II Permanent Link 2	PASS	PASS	PASS

Octobyte connectors pass the test of TIA/EIA 568 Cat 8 permanent link and ISO 11801 Class II Permanent link with positive result.

As per graphs below the difference between measure on: only cable / 1 connection / 2 connection are similar. Octobyte connectors connection affect low on the performance.



Issue date	22/06/21
Test Report	
TR	170-21
Pag. 5 of 36	Rev. 0

Insertion Loss comparison

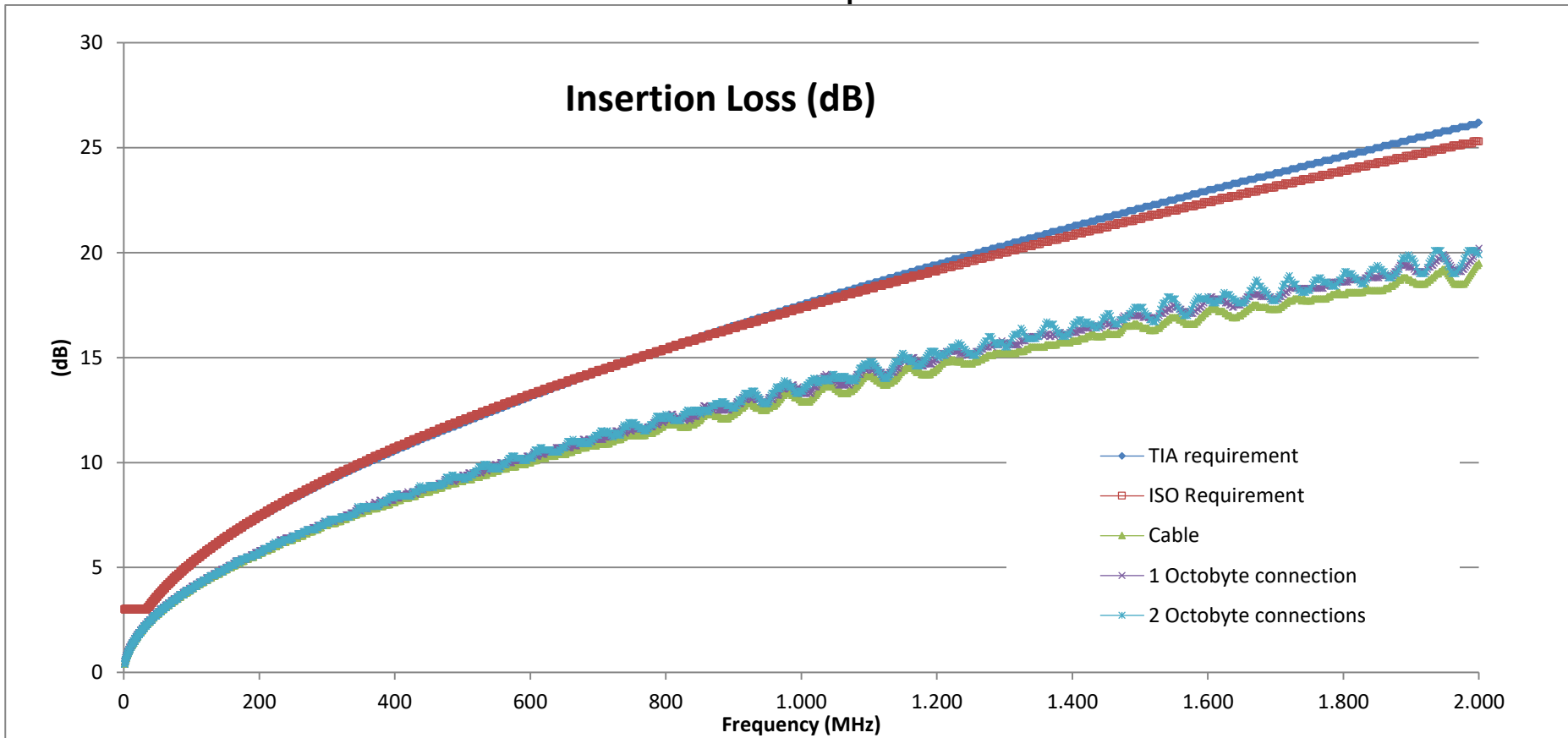

Graph was made with the minimum value of Insertion loss between pairs for each frequency.



Issue date	22/06/21
Test Report	
TR	170-21
Pag. 6 of 36	Rev. 0

NEXT comparison

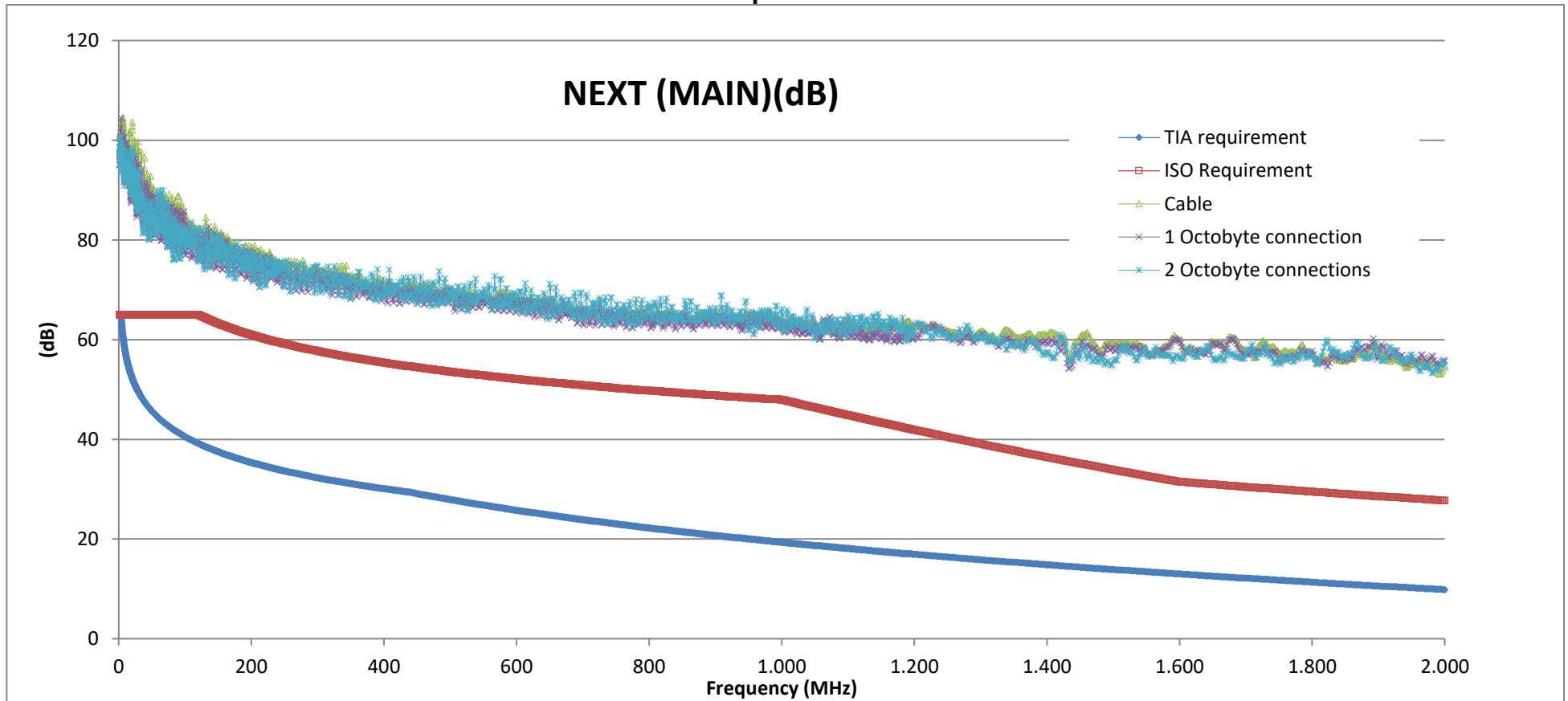

Graph was made with the minimum value of Next between pairs for each frequency.



Issue date	22/06/21
Test Report	
TR	170-21
Pag. 7 of 36	Rev. 0

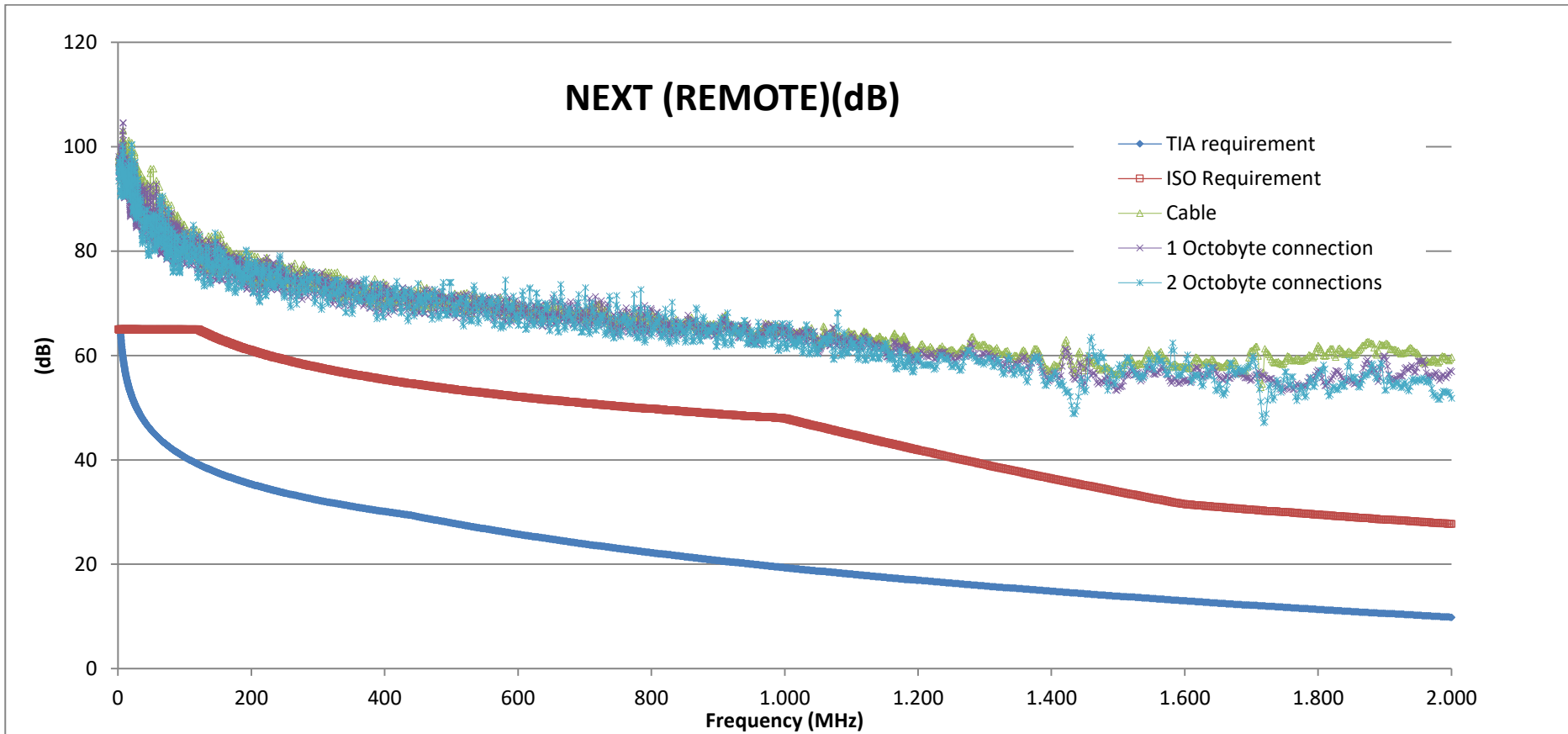

Graph was made with the minimum value of Next between pairs for each frequency.



Issue date	22/06/21
Test Report	
TR	170-21
Pag. 8 of 36	Rev. 0

Return Loss comparison

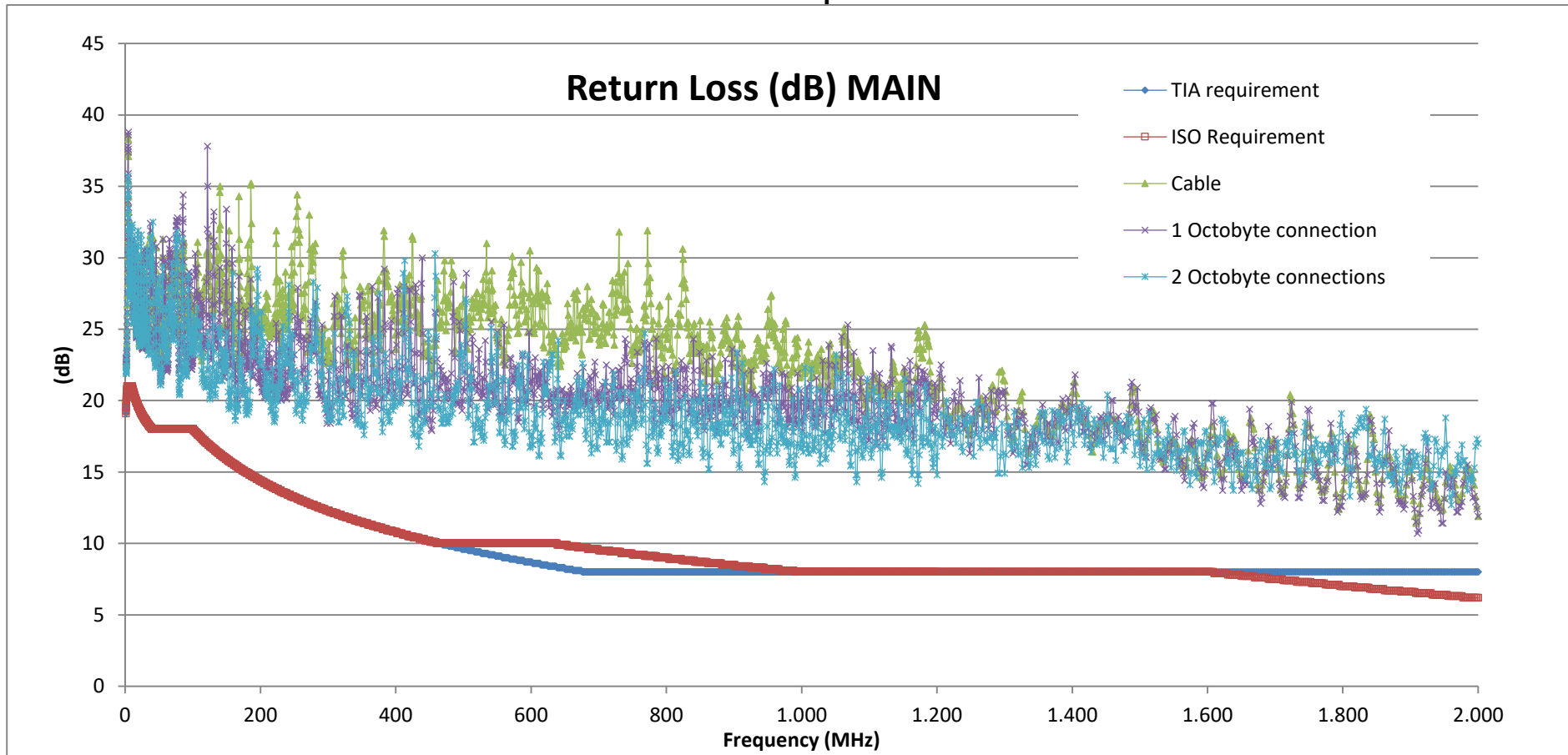

Graph was made with the minimum value of Return loss between pairs for each frequency.



Issue date	22/06/21
Test Report	
TR	170-21
Pag. 9 of 36	Rev. 0

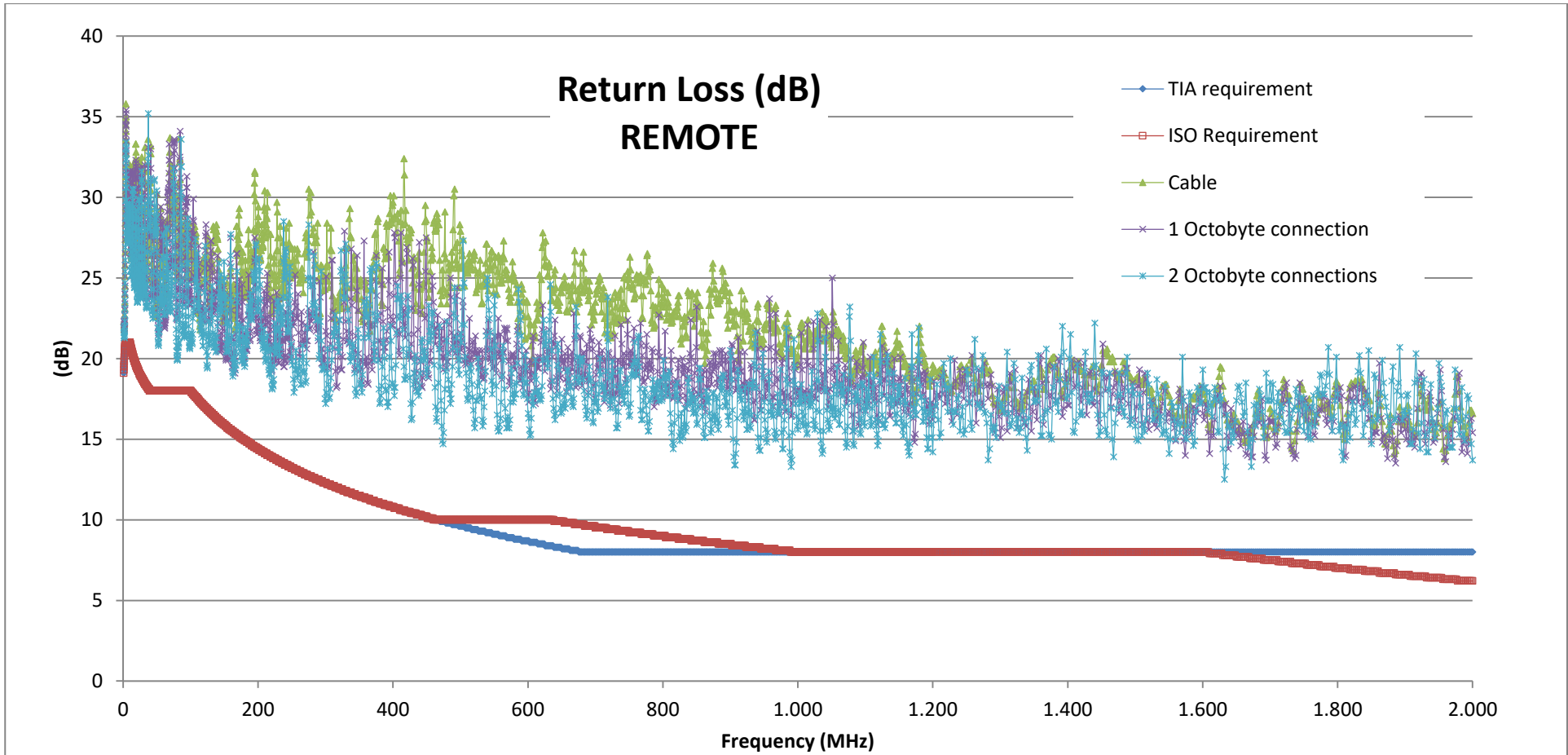

Graph was made with the minimum value of Return loss between pairs for each frequency.

	Issue date	22/06/21
	Test Report	
	TR	170-21
	Pag. 10 of 36	Rev. 0

Description of samples – descrizione dei campioni:

Cable: ROLINE S/FTP Cable Cat.8 (Class I), Solid Wire LSOH

Octobyte Plug connector: Q08P-F11-7A 3113313713



Octobyte Socket connector: Q08S-F11-7A 3113313714





Issue date

22/06/21

Test Report

TR

170-21

Pag. 11 of 36

Rev. 0

Jumper configuration

Octobyte plug – 2,5mt – Octobyte Plug



Receptacle configuration

Tera Socket – cable – Octobyte socket



	Issue date	22/06/21
	Test Report	
	TR	170-21
	Pag. 12 of 36	Rev. 0

Date of receipt of samples – data di ricezione campioni: 09/06/21

List of tests – lista delle prove:	Standard / specification applicable – norme / specifiche applicabili	Testlab procedure cross – reference – Procedura Testlab
1. Ethernet test - Permanent Link	ISO/IEC 11801:Edition 2.0 2010-04 ; ANSI/TIA-568-D	---

Comments / remarks / test deviations – commenti / osservazioni/ deviazioni:



1. Ethernet Test – CAT8

1.1. Description of Test method procedure – Descrizione della procedura del metodo di prova

Testing as per ISO/IEC 11801 Cat 8 II Permeant link and ANSI/TIA 568 Category 8 Permanent Link.

Configuration:

Test configuration:

Only cable (as reference)

- Socket Tera connector – 24 meter of cable – Socket Tera connector.

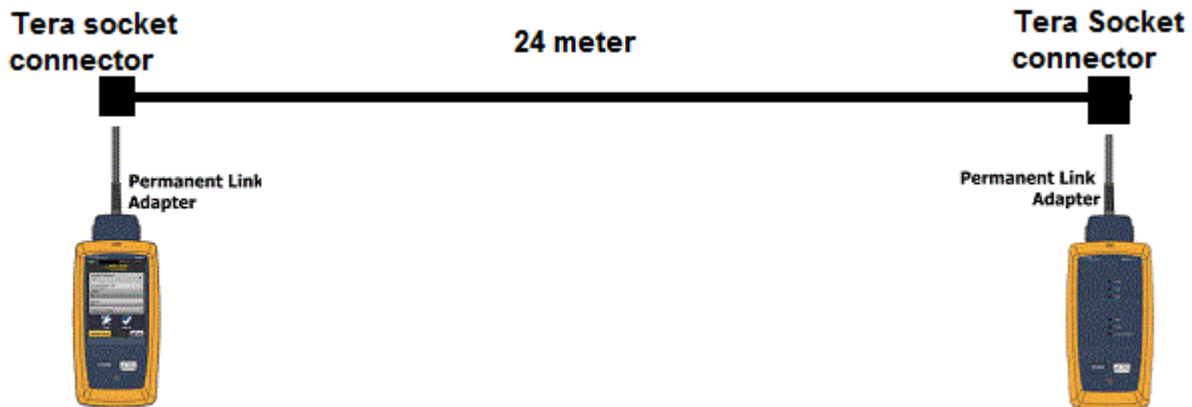

1 Octobyte connection:

- Socket Tera connector – 12 meter of cable – Octobyte socket connector **mated with** Octobyte Plug connector – 12 meter of cable - Socket Tera connector.

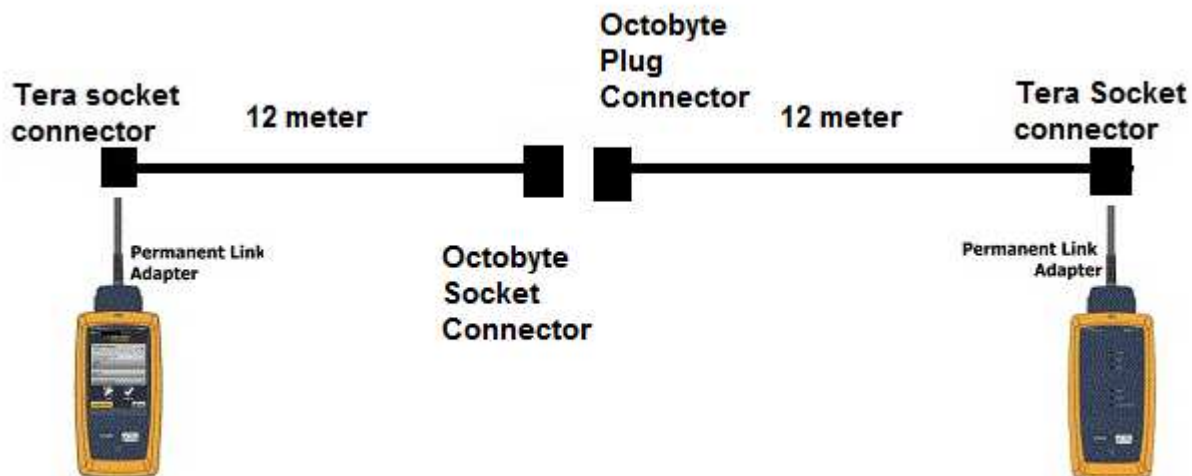



Test Report

2 Octobyte connections:

- Socket Tera connector – 12 meter of cable – Octobyte socket connector **mated with** Octobyte Plug connector – 2,5 meter of cable – Octobyte Plug connector **mated with** Octobyte Socket connector – 9,5 meter of cable - Socket Tera connector.

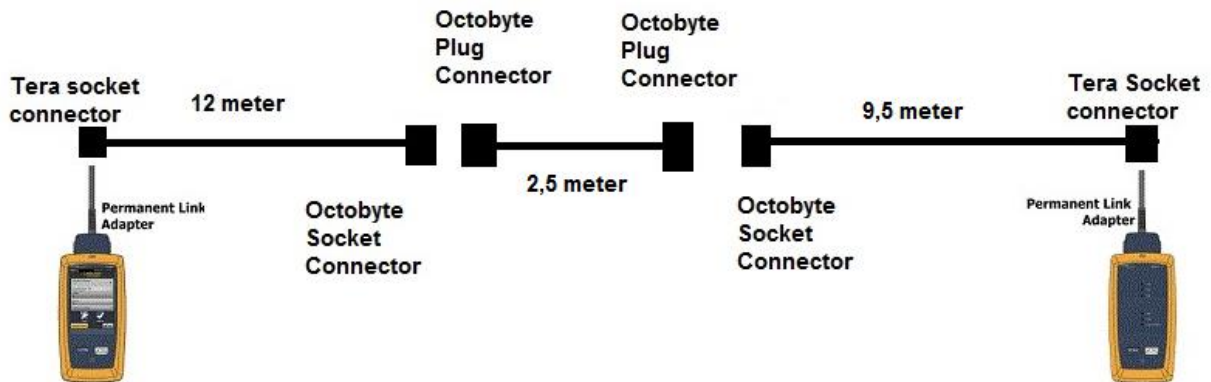

TEST SETUP



	Issue date	22/06/21
	Test Report	
	TR	170-21
	Pag. 15 of 36	Rev. 0

1.2. Items tested – campioni sottoposti a prova

As above.

1.3. Relevant equipment – strumenti utilizzati

Equipment Strumento	Internal code Codice interno	Serial Number Numero di matricola	Manufacturer / model – marca / modello	Calibration expiration date – scadenza taratura
LAN cable certifier	DSX8000	1932179+19345288; 19320145+1932375	Fluke / DSX-8000	12/21

1.4. Requirement - requisiti

PASS.

1.5. Date and place of test – data e luogo della prova

09/06/21; 18/06/21 – Glenair Italia Test laboratory – Environmental Test Room

1.6. Environmental conditions – condizioni ambientali

Date	Temperature	Humidity	Atmospheric pressure (hPa)
09/06/21	23,4°C	38,7 %RH	1011
18/06/21	23,1°C	45,6 %RH	1016

1.7. Result – risultati



Issue date 22/06/21

Test Report

TR

170-21

Pag. 16 of 36

Rev. 0

Test on Cable – ANSI/TIA Cat. 8 Permanent Link



Cable ID: TERA 24MT CAT8 TIA PERM

PASS

Cat 8 S/FTP
06/01/2021 02:49 PM

TIA Cat 8 Perm. Link (+All)
DSX-8000

Headroom (NEXT): 29.4 dB
S/N: 1932179

Tests	Detail	Status	Value	Limit	Margin
Insertion Loss (dB)	Pair 4,5, 1958.0 MHz	PASS	20.1	25.8	5.7
NEXT (dB)	Pair 3,6-4,5, 3.3 MHz	PASS	94.4	65.0	29.4
PS NEXT (dB)	Pair 3,6, 3.3 MHz	PASS	92.1	62.0	30.1
ACR-N (dB)	Pair 3,6-4,5, 3.3 MHz	N/A	93.7	62.0	31.7
PS ACR-N (dB)	Pair 3,6, 3.3 MHz	N/A	91.4	59.0	32.4
ACR-F (dB)	Pair 3,6-1,2, 1.1 MHz	PASS	93.1	71.4	21.7
PS ACR-F (dB)	Pair 3,6, 1.1 MHz	PASS	90.9	68.4	22.5
RL (dB)	Pair 7,8, 1908.0 MHz	PASS	11.4	8.0	3.4
TCL (dB)	Pair 4,5, 87.8 MHz	PASS	30.4	24.0	6.4
CDNEXT (dB)	Pair 7,8-4,5, 1402.0 MHz		42.5		
CMRL (dB)	Pair 4,5, 1654.0 MHz		5.0		
ELTCTL (dB)	Pair 4,5, 1.0 MHz	PASS	52.6	46.8	5.8
Length (m)	Pair 7,8	PASS	23.5	24.0	0.5
Prop. Delay (ns)	Pair 3,6	PASS	112	136	24
Delay Skew (ns)	Pair 3,6	PASS	3	13	10
Resistance (ohms)	Pair 3,6	PASS	3.00	5.60	2.60
Resistance Unbalance (ohms)	Pair 3,6	PASS	0.012	0.100	0.088
Resistance P2P Unbalance (ohms)	Pair 3,6-7,8	PASS	0.008	0.200	0.192
Wire Map		PASS			



Issue date

22/06/21

Test Report

TR

170-21

Pag. 17 of 36

Rev. 0



Cable ID: TERA 24MT CAT8 TIA PERM

Test Summary: PASS

Test Limit: TIA Cat 8 Perm. Link (+All)

Limits Version: V7.5

Date / Time: 06/01/2021 02:49:07 PM

Operator: SIMONE CREMONINI

Headroom 29.4 dB (NEXT 3,6-4,5)

Cable Type: Cat 8 S/FTP

NVP: 72.0%

Main: Versiv

S/N: 1932179

Software Version: V6.5 Build 5

Calibration Date: 05/14/2020

Adapter: DSX-8000 (DSX-PLA-8-TERA)

S/N: 19470006

Remote: Versiv

S/N: 1932375

Software Version: V6.5 Build 5

Calibration Date: 05/12/2020

Adapter: DSX-8000R (DSX-PLA-8-TERA)

S/N: 19470005

Wire Map	1	2	3	4	5	6	7	8	9
PASS	1	1	1	1	1	1	1	1	1
(T568B)	1	2	3	4	5	6	7	8	9

Length (m), Limit 24.0	[Pair 7,8]	23.5
Prop. Delay (ns), Limit 136	[Pair 3,6]	112
Delay Skew (ns), Limit 13	[Pair 3,6]	3
Resistance (ohms), Limit 5.60	[Pair 3,6]	3.00
Resist Unbal. (ohms), Limit 0.100	[Pair 3,6]	0.012
Resist P2P Unbal. (ohms), Limit 0.200	[Pair 3,6-7,8]	0.008

Insertion Loss Margin (dB)	[Pair 4,5]	5.7
Frequency (MHz)	[Pair 4,5]	1958.0
Limit (dB)	[Pair 4,5]	25.8

Worst Case Margin Worst Case Value

PASS	MAIN	SR	MAIN	SR
Worst Pair	1,2-3,6	3,6-4,5	4,5-7,8	1,2-3,6
NEXT (dB)	30.1	29.4	43.2	41.9
Freq. (MHz)	1.1	3.3	1992.	1714.
Limit (dB)	65.0	65.0	9.9	12.0
Worst Pair	3,6	3,6	4,5	3,6
PS NEXT (dB)	31.1	30.1	45.1	44.7
Freq. (MHz)	1.1	3.3	1992.	1714.
Limit (dB)	62.0	62.0	6.1	8.3

PASS	MAIN	SR	MAIN	SR
Worst Pair	1,2-3,6	3,6-1,2	7,8-4,5	3,6-1,2
ACR-F (dB)	21.8	21.7	40.0	39.7
Freq. (MHz)	1.1	1.1	1960.	1690.
Limit (dB)	71.4	71.4	6.6	7.8
Worst Pair	3,6	3,6	4,5	4,5
PS ACR-F (dB)	22.5	23.4	41.9	42.5
Freq. (MHz)	1.1	1.0	1962.	1972.
Limit (dB)	68.4	69.4	3.5	3.5

N/A	MAIN	SR	MAIN	SR
Worst Pair	1,2-3,6	3,6-4,5	4,5-7,8	1,2-3,6
ACR-N (dB)	32.7	31.7	50.1	46.3
Freq. (MHz)	1.1	3.3	1992.	1714.
Limit (dB)	62.0	62.0	-16.2	-11.9
Worst Pair	3,6	3,6	4,5	3,6
PS ACR-N (dB)	33.7	32.4	51.8	49.1
Freq. (MHz)	1.1	3.3	1992.	1714.
Limit (dB)	59.0	59.0	-20.1	-15.6

PASS	MAIN	SR	MAIN	SR
Worst Pair	7,8	7,8	7,8	4,5
RL (dB)	3.4	4.5	3.4	5.8
Freq. (MHz)	1908.	114.0	1908.	1958.
Limit (dB)	8.0	17.3	8.0	8.0

Compliant Network Standards:

10BASE-T	100BASE-TX	100BASE-T4
1000BASE-T	2.5GBASE-T	5GBASE-T
10GBASE-T	25GBASE-T	40GBASE-T
ATM-25	ATM-S1	ATM-155
100VG-AnyLan	TR-4	TR-16 Active

Project: CAT8_2.1
CAT8 Test-fw

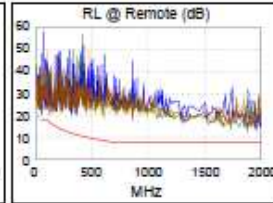
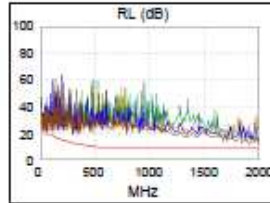
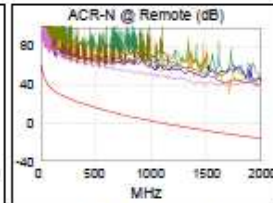
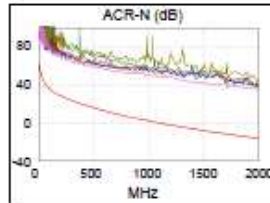
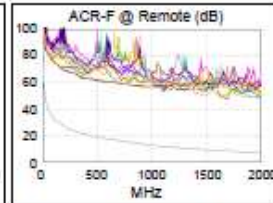
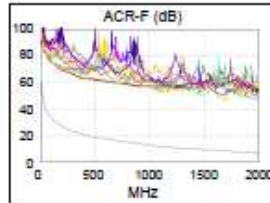
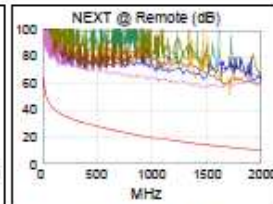
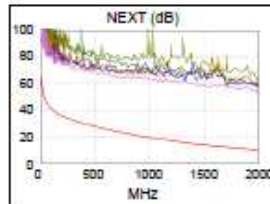

LinkWare™ PC Version 10.7





Issue date

22/06/21

Test Report

TR

170-21

Pag. 18 of 36

Rev. 0



Cable ID: TERA 24MT CAT8 TIA PERM

Test Summary: PASS

Test Limit: TIA Cat 8 Perm. Link (+All)
 Limits Version: V7.5
 Date / Time: 06/01/2021 02:49:07 PM
 Operator: SIMONE CREMONINI
 Headroom 29.4 dB (NEXT 3,6-4,5)
 Cable Type: Cat 8 S/FTP
 NVP: 72.0%

Main: Versiv
 S/N: 1932179
 Software Version: V6.5 Build 5
 Calibration Date: 05/14/2020
 Adapter: DSX-8000 (DSX-PLA-8-TERA)
 S/N: 19470006

Remote: Versiv
 S/N: 1932375
 Software Version: V6.5 Build 5
 Calibration Date: 05/12/2020
 Adapter: DSX-8000R (DSX-PLA-8-TERA)
 S/N: 19470005

	Worst Case Margin		Worst Case Value	
	MAIN	SR	MAIN	SR
PASS				
Worst Pair	4,5	1,2	1,2	1,2
TCL (dB)	6.4	6.9	9.6	11.5
Freq. (MHz)	87.8	29.8	370.0	369.0
Limit (dB)	24.0	32.0	13.3	13.4
N/A				
Worst Pair			7,8-4,5	7,8-4,5
CDNEXT (dB)			39.3	42.5
Freq. (MHz)			1434.	1402.
Limit (dB)				
N/A				
Worst Pair			4,5	4,5
CMRL (dB)			3.5	5.0
Freq. (MHz)			1640.	1654.
Limit (dB)				
PASS				
Worst Pair	4,5	4,5	3,6	1,2
ELTCTL (dB)	5.8	6.7	14.8	14.7
Freq. (MHz)	1.0	1.0	2000.	2000.
Limit (dB)	46.8	46.8	3.0	3.0

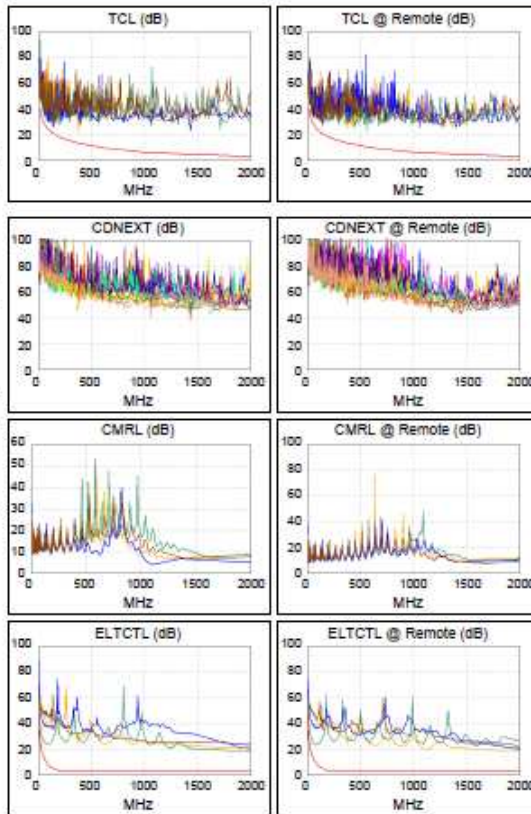

LinkWare™ PC Version: 10.7.



Issue date 22/06/21

Test Report

TR

170-21

Pag. 19 of 36

Rev. 0

Test on Cable – ISO/IEC 11801 Cat. II Permanent Link 2



Cable ID: TERA 24MT CAT8 II PL2

PASS

Cat 8 S/FTP
06/01/2021 02:43 PM

ISO11801 PL Class II (+All)
DSX-8000

Headroom (NEXT): 12.1 dB
S/N: 1932179

Tests	Detail	Status	Value	Limit	Margin
Insertion Loss (dB)	Pair 4,5, 1958.0 MHz	PASS	20.1	25.0	4.9
NEXT (dB)	Pair 4,5-7,8, 142.5 MHz	PASS	75.7	63.6	12.1
PS NEXT (dB)	Pair 7,8, 124.5 MHz	PASS	75.3	61.7	13.6
ACR-N (dB)	Pair 4,5-7,8, 142.5 MHz	PASS	70.9	57.4	13.5
PS ACR-N (dB)	Pair 7,8, 124.5 MHz	PASS	70.8	55.9	14.9
ACR-F (dB)	Pair 3,6-4,5, 414.0 MHz	PASS	61.4	41.2	20.2
PS ACR-F (dB)	Pair 4,5, 369.0 MHz	PASS	61.0	39.2	21.8
RL (dB)	Pair 7,8, 114.0 MHz	PASS	21.7	17.3	4.4
TCL (dB)	Pair 4,5, 87.8 MHz	PASS	30.4	17.0	13.4
CDNEXT (dB)	Pair 7,8-4,5, 1402.0 MHz		42.5		
CMRL (dB)	Pair 4,5, 1648.0 MHz		5.0		
ELTCTL (dB)	Pair 1,2, 2000.0 MHz	PASS	17.7	3.0	14.7
Length (m)	Pair 7,8		23.5		
Prop. Delay (ns)	Pair 3,6	PASS	112	147	35
Delay Skew (ns)	Pair 3,6	PASS	3	9	6
Resistance (ohms)	Pair 3,6	PASS	3.01	6.00	2.99
Resistance Unbalance (ohms)	Pair 1,2	PASS	0.016	0.200	0.184
Resistance P2P Unbalance (ohms)	Pair 3,6-7,8	PASS	0.009	0.200	0.191
Wire Map		PASS			



Issue date

22/06/21

Test Report

TR

170-21

Pag. 20 of 36

Rev. 0



Cable ID: TERA 24MT CAT8 II PL2

Test Summary: PASS

Test Limit: ISO11801 PL Class II (+All)

Main: Versiv

Remote: Versiv

Limits Version: V7.5

S/N: 1932179

S/N: 1932375

Date / Time: 06/01/2021 02:43:33 PM

Software Version: V6.5 Build 5

Software Version: V6.5 Build 5

Operator: SIMONE CREMONINI

Calibration Date: 05/14/2020

Calibration Date: 05/12/2020

Headroom 12.1 dB (NEXT 4,5-7,8)

Adapter: DSX-8000 (DSX-PLA-8-TERA)

Adapter: DSX-8000R (DSX-PLA-8-TERA)

Cable Type: Cat 8 S/FTP

S/N: 19470006

S/N: 19470005

NVP: 72.0%

Wire Map	1	2	3	4	5	6	7	8	8
PASS									
(T568B)	1	2	3	4	5	6	7	8	8



Length (m)	[Pair 7,8]	23.5
Prop. Delay (ns), Limit 147	[Pair 3,8]	112
Delay Skew (ns), Limit 9	[Pair 3,8]	3
Resistance (ohms), Limit 6.00	[Pair 3,6]	3.01
Resist. Unbal. (ohms), Limit 0.200	[Pair 1,2]	0.016
Resist. P2P Unbal. (ohms), Limit 0.200	[Pair 3,6-7,8]	0.009
Insertion Loss Margin (dB)	[Pair 4,5]	4.9
Frequency (MHz)	[Pair 4,5]	1958.0
Limit (dB)	[Pair 4,5]	25.0

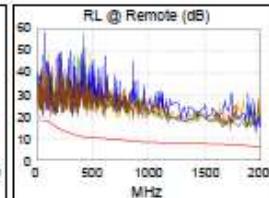
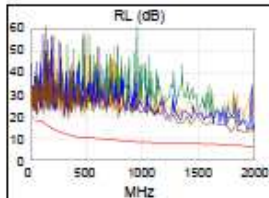
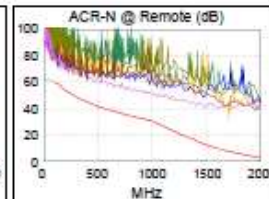
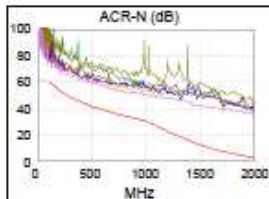
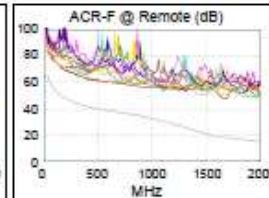
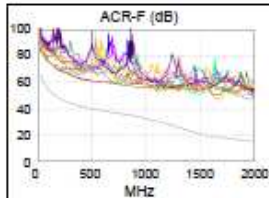
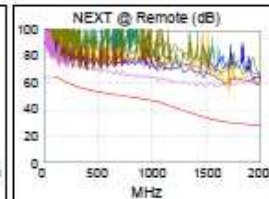
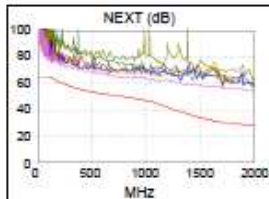
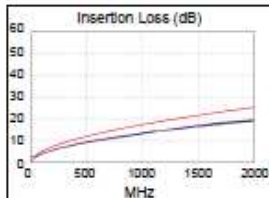

	Worst Case Margin		Worst Case Value	
PASS	MAIN	SR	MAIN	SR
Worst Pair	4,5-7,8	4,5-7,8	4,5-7,8	1,2-3,6
NEXT (dB)	12.7	12.1	25.1	23.9
Freq. (MHz)	272.0	142.5	1992.	1714.
Limit (dB)	58.5	63.6	27.8	30.3
Worst Pair	7,8	7,8	4,5	3,6
PS NEXT (dB)	13.6	14.0	26.3	26.0
Freq. (MHz)	124.5	134.0	1992.	1714.
Limit (dB)	61.7	61.1	24.8	27.3

PASS	MAIN	SR	MAIN	SR
Worst Pair	3,6-4,5	4,5-3,6	7,8-4,5	3,6-1,2
ACR-F (dB)	20.2	20.3	31.4	30.0
Freq. (MHz)	414.0	419.0	1968.	1892.
Limit (dB)	41.2	41.1	15.1	17.6
Worst Pair	4,5	4,5	4,5	4,5
PS ACR-F (dB)	21.9	21.8	33.4	34.0
Freq. (MHz)	1054.	369.0	1972.	1974.
Limit (dB)	29.1	39.2	12.0	12.0

PASS	MAIN	SR	MAIN	SR
Worst Pair	4,5-7,8	4,5-7,8	4,5-7,8	1,2-3,6
ACR-N (dB)	14.2	13.5	31.2	27.8
Freq. (MHz)	124.5	142.5	1992.	1714.
Limit (dB)	58.9	57.4	2.5	7.0
Worst Pair	7,8	7,8	4,5	3,6
PS ACR-N (dB)	14.9	15.4	32.1	29.9
Freq. (MHz)	124.5	134.0	1992.	1714.
Limit (dB)	55.9	55.1	-0.5	4.0

PASS	MAIN	SR	MAIN	SR
Worst Pair	4,5	7,8	7,8	4,5
RL (dB)	4.7	4.4	5.4	7.3
Freq. (MHz)	52.3	114.0	1908.	1958.
Limit (dB)	18.0	17.3	6.5	6.3

Compliant Network Standards:
 10BASE-T 100BASE-TX 100BASE-T4
 1000BASE-T 2.5GBASE-T 5GBASE-T
 10GBASE-T 25GBASE-T 40GBASE-T
 ATM-25 ATM-51 ATM-155
 100VG-AnyLan TR-4 TR-16 Active

LinkWare™ PC, Version 10.7

Project: CAT8_2_1
 CAT8 Test-fw





Issue date

22/06/21

Test Report

TR

170-21

Pag. 21 of 36

Rev. 0



Cable ID: TERA 24MT CAT8 II PL2

Test Summary: PASS

Test Limit: ISO11801 PL Class II (+All)

Main: Versiv

Remote: Versiv

Limits Version: V7.5

S/N: 1932179

S/N: 1932375

Date / Time: 06/01/2021 02:43:33 PM

Software Version: V6.5 Build 5

Software Version: V6.5 Build 5

Operator: SIMONE CREMONINI

Calibration Date: 05/14/2020

Calibration Date: 05/12/2020

Headroom 12.1 dB (NEXT 4,5-7,8)

Adapter: DSX-8000 (DSX-PLA-8-TERA)

Adapter: DSX-8000R (DSX-PLA-8-TERA)

Cable Type: Cat 8 S/FTP

S/N: 19470006

S/N: 19470005

NVP: 72.0%

	Worst Case Margin		Worst Case Value	
	MAIN	SR	MAIN	SR
PASS				
Worst Pair	4,5	1,2	1,2	1,2
TCL (dB)	13,4	13,9	16,7	18,6
Freq. (MHz)	87,8	29,8	370,0	369,0
Limit (dB)	17,0	25,0	6,3	6,4
N/A				
Worst Pair			7,8-4,5	7,8-4,5
CDNEXT (dB)			39,4	42,5
Freq. (MHz)			1434,	1402,
Limit (dB)				
N/A				
Worst Pair			4,5	4,5
CMRL (dB)			3,5	5,0
Freq. (MHz)			1644,	1648,
Limit (dB)				
PASS				
Worst Pair	3,5	1,2	3,5	1,2
ELTCTL (dB)	14,8	14,7	14,8	14,7
Freq. (MHz)	2000,	2000,	2000,	2000,
Limit (dB)	3,0	3,0	3,0	3,0

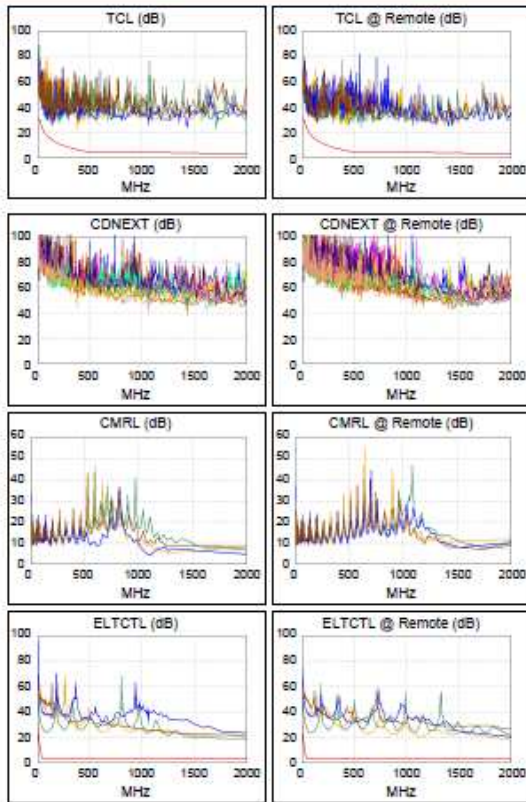

LinkWare™ PC Version 10.7



Issue date 22/06/21

Test Report

TR

170-21

Pag. 22 of 36

Rev. 0

Test on 1 OctoByte connection – ANSI/TIA Cat. 8 Permanent Link



Cable ID: TERA + 1 OCTO CAT8 TIA P

PASS

Cat 8 S/FTP

TIA Cat 8 Perm. Link (+All)

Headroom (NEXT): 29.1 dB

06/09/2021 01:47 PM

DSX-8000

S/N: 1932179

Tests	Detail	Status	Value	Limit	Margin
Insertion Loss (dB)	Pair 3,6, 1982.0 MHz	PASS	20.8	26.0	5.2
NEXT (dB)	Pair 3,6-7,8, 1.9 MHz	PASS	94.1	65.0	29.1
PS NEXT (dB)	Pair 7,8, 3.3 MHz	PASS	92.3	62.0	30.3
ACR-N (dB)	Pair 3,6-7,8, 1.9 MHz	N/A	93.5	62.0	31.5
PS ACR-N (dB)	Pair 7,8, 3.3 MHz	N/A	91.6	59.0	32.6
ACR-F (dB)	Pair 4,5-3,6, 1.0 MHz	PASS	93.1	72.4	20.7
PS ACR-F (dB)	Pair 4,5, 1.0 MHz	PASS	91.2	69.4	21.8
RL (dB)	Pair 7,8, 1910.0 MHz	PASS	10.7	8.0	2.7
TCL (dB)	Pair 4,5, 87.8 MHz	PASS	30.3	24.0	6.3
CDNEXT (dB)	Pair 7,8-4,5, 1400.0 MHz		42.7		
CMRL (dB)	Pair 4,5, 1646.0 MHz		5.6		
ELTCTL (dB)	Pair 4,5, 1.0 MHz	PASS	52.4	46.8	5.6
Length (m)	Pair 7,8	PASS	23.5	24.0	0.5
Prop. Delay (ns)	Pair 3,6	PASS	112	136	24
Delay Skew (ns)	Pair 3,6	PASS	3	13	10
Resistance (ohms)	Pair 3,6	PASS	3.03	5.60	2.57
Resistance Unbalance (ohms)	Pair 1,2	PASS	0.014	0.100	0.086
Resistance P2P Unbalance (ohms)	Pair 3,6-7,8	PASS	0.007	0.200	0.193
Wire Map		PASS			



Issue date

22/06/21

Test Report

TR

170-21

Pag. 23 of 36

Rev. 0



Cable ID: TERA + 1 OCTO CAT8 TIA P

Test Summary: **PASS**

Test Limit: TIA Cat 8 Perm. Link (+All)
 Limits Version: V7.6
 Date / Time: 06/09/2021 01:47:59 PM
 Operator: SIMONE CREMONINI
 Headroom 29.1 dB (NEXT 3,6-7,8)
 Cable Type: Cat 8 S/FTP
 NVP: 72.0%

Main: Versiv
 S/N: 1932179
 Software Version: V6.6 Build 2
 Calibration Date: 05/14/2020
 Adapter: DSX-8000 (DSX-PLA-8-TERA)
 S/N: 19470006

Remote: Versiv
 S/N: 1932375
 Software Version: V6.6 Build 2
 Calibration Date: 05/12/2020
 Adapter: DSX-8000R (DSX-PLA-8-TERA)
 S/N: 19470005

Wire Map	1 2 3 4 5 6 7 8 9
PASS	
(T568B)	1 2 3 4 5 6 7 8 9

Length (m), Limit 24.0	[Pair 7,8]	23.5
Prop. Delay (ns), Limit 136	[Pair 3,6]	112
Delay Skew (ns), Limit 13	[Pair 3,6]	3
Resistance (ohms), Limit 5.60	[Pair 3,8]	3.03
Resist Unbal. (ohms), Limit 0.100	[Pair 1,2]	0.014
Resist P2P Unbal. (ohms), Limit 0.200	[Pair 3,6-7,8]	0.007
Insertion Loss Margin (dB)	[Pair 3,6]	5.2
Frequency (MHz)	[Pair 3,6]	1982.0
Limit (dB)	[Pair 3,6]	26.0

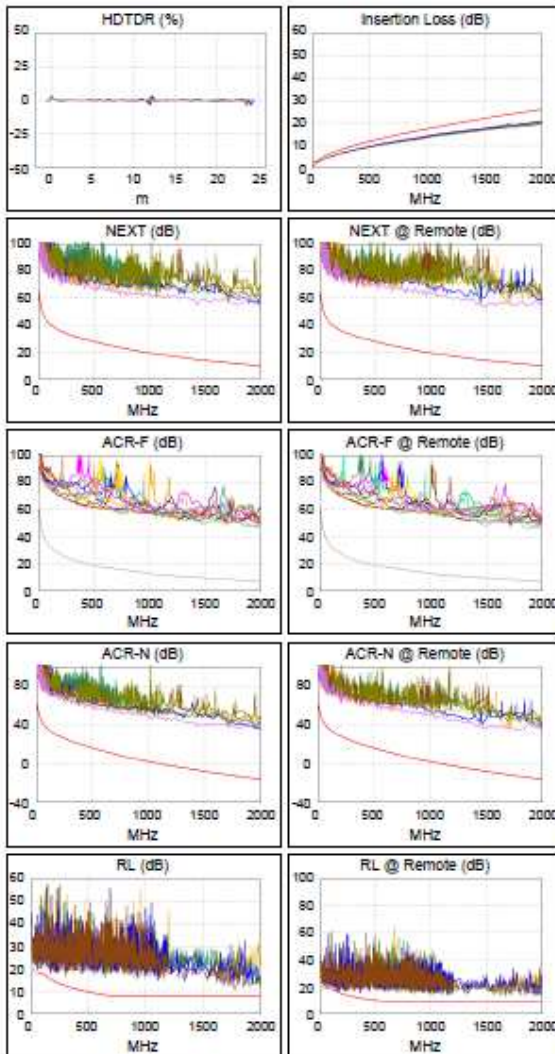

	Worst Case Margin		Worst Case Value	
PASS	MAIN	SR	MAIN	SR
Worst Pair	3,6-7,8	3,6-7,8	4,5-7,8	4,5-7,8
NEXT (dB)	30.0	29.1	39.7	41.4
Freq. (MHz)	1.4	1.9	1432.	1746.
Limit (dB)	65.0	65.0	14.5	11.8
Worst Pair	3,6	7,8	7,8	7,8
PS NEXT (dB)	30.8	30.3	46.1	42.2
Freq. (MHz)	1.4	3.3	1994.	1498.
Limit (dB)	62.0	62.0	6.0	10.2
PASS	MAIN	SR	MAIN	SR
Worst Pair	4,5-3,6	3,6-4,5	7,8-4,5	7,8-4,5
ACR-F (dB)	20.7	20.7	39.9	39.5
Freq. (MHz)	1.0	1.0	1966.	1864.
Limit (dB)	72.4	72.4	6.5	7.0
Worst Pair	3,6	4,5	1,2	4,5
PS ACR-F (dB)	22.7	21.8	40.4	41.2
Freq. (MHz)	1.0	1.0	2000.	1990.
Limit (dB)	69.4	69.4	3.4	3.4
N/A	MAIN	SR	MAIN	SR
Worst Pair	3,6-7,8	3,6-7,8	4,5-7,8	4,5-7,8
ACR-N (dB)	32.5	31.5	51.4	47.3
Freq. (MHz)	1.4	1.9	1994.	1746.
Limit (dB)	62.0	62.0	-16.2	-12.4
Worst Pair	3,6	7,8	7,8	7,8
PS ACR-N (dB)	33.3	32.6	52.2	53.7
Freq. (MHz)	1.4	3.3	1994.	2000.
Limit (dB)	59.0	59.0	-20.1	-20.2
PASS	MAIN	SR	MAIN	SR
Worst Pair	7,8	4,5	7,8	7,8
RL (dB)	2.7	3.5	2.7	5.5
Freq. (MHz)	1910.	52.5	1910.	1866.
Limit (dB)	8.0	18.0	8.0	8.0

Compliant Network Standards:		
10BASE-T	100BASE-TX	100BASE-T4
1000BASE-T	2.5GBASE-T	5GBASE-T
10GBASE-T	25GBASE-T	40GBASE-T
ATM-25	ATM-S1	ATM-155
100VG-AnyLan	TR-4	TR-16 Active

LinkWare™ PC Version: 10.7

Project: CAT8 Test-1
 CAT8 Test-fw





Issue date

22/06/21

Test Report

TR

170-21

Pag. 24 of 36

Rev. 0



Cable ID: TERA + 1 OCTO CAT8 TIA P

Test Summary: PASS

Test Limit: TIA Cat 8 Perm. Link (+All)
 Limits Version: V7.6
 Date / Time: 06/09/2021 01:47:59 PM
 Operator: SIMONE CREMONINI
 Headroom 29.1 dB (NEXT 3,6-7,8)
 Cable Type: Cat 8 S/FTP
 NVP: 72.0%

Main: Versiv
 S/N: 1932179
 Software Version: V6.6 Build 2
 Calibration Date: 05/14/2020
 Adapter: DSX-8000 (DSX-PLA-8-TERA)
 S/N: 19470006

Remote: Versiv
 S/N: 1932375
 Software Version: V6.6 Build 2
 Calibration Date: 05/12/2020
 Adapter: DSX-8000R (DSX-PLA-8-TERA)
 S/N: 19470005

	Worst Case Margin		Worst Case Value	
PASS	MAIN	SR	MAIN	SR
Worst Pair	4,5	1,2	4,5	3,6
TCL (dB)	6,3	6,6	18,4	13,1
Freq. (MHz)	87,8	29,8	1434,	447,0
Limit (dB)	24,0	32,0	3,3	11,9
N/A	MAIN	SR	MAIN	SR
Worst Pair			7,8-4,5	7,8-4,5
CDNEXT (dB)			38,9	42,7
Freq. (MHz)			1432,	1400,
Limit (dB)				
N/A	MAIN	SR	MAIN	SR
Worst Pair			4,5	4,5
CMRL (dB)			3,3	5,6
Freq. (MHz)			1196,	1646,
Limit (dB)				
PASS	MAIN	SR	MAIN	SR
Worst Pair	4,5	4,5	3,6	1,2
ELTCTL (dB)	5,6	6,3	14,4	13,8
Freq. (MHz)	1,0	1,0	2000,	2000,
Limit (dB)	46,8	46,8	3,0	3,0

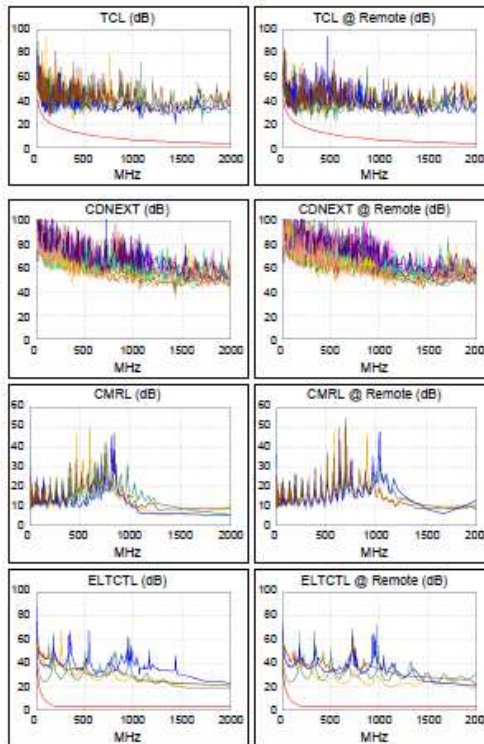

LinkWare™ PC Version 10.7





Issue date

22/06/21

Test Report

TR

170-21

Pag. 25 of 36

Rev. 0

HDTDx – 1 Octobite Connection

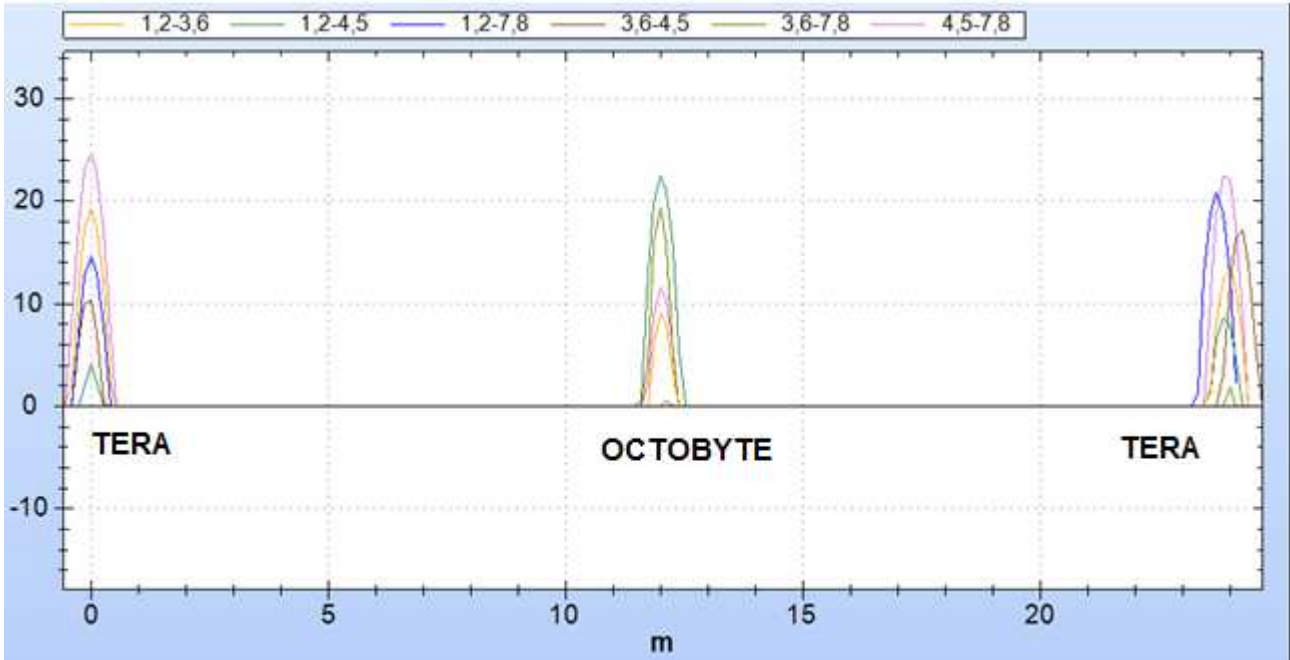

HDTDdR – 1 Octobite Connection

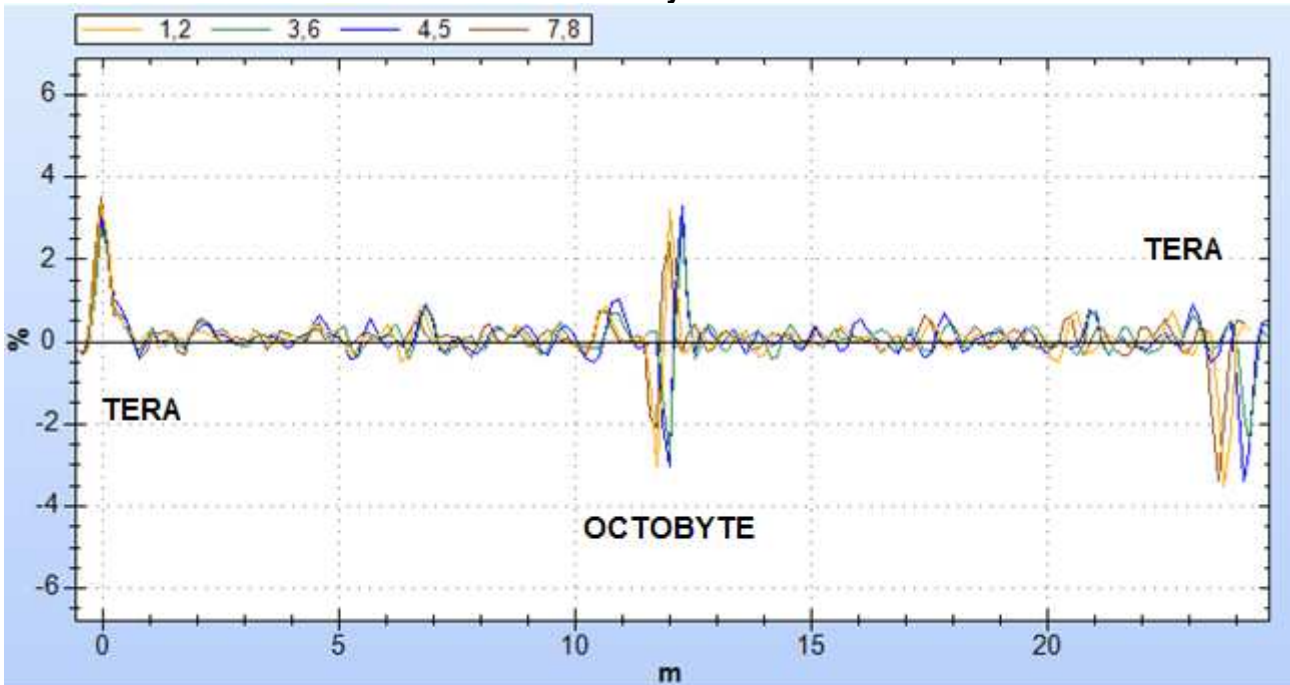



Issue date 22/06/21

Test Report

TR

170-21

Pag. 26 of 36

Rev. 0

Test on 1 Octobyte connection – ISO/IEC 11801 Cat. II Permanent Link 2



Cable ID: TERA + 1 OCTO CAT8 ISO II P

PASS

Cat 8 S/FTP
06/09/2021 01:46 PM

ISO11801 PL Class II (+All)
DSX-8000

Headroom (NEXT): 10.5 dB
S/N: 1932179

Tests	Detail	Status	Value	Limit	Margin
Insertion Loss (dB)	Pair 3,6, 1980.0 MHz	PASS	20.8	25.2	4.4
NEXT (dB)	Pair 4,5-7,8, 137.5 MHz	PASS	74.4	63.9	10.5
PS NEXT (dB)	Pair 7,8, 129.0 MHz	PASS	73.8	61.4	12.4
ACR-N (dB)	Pair 4,5-7,8, 137.5 MHz	PASS	69.7	57.8	11.9
PS ACR-N (dB)	Pair 7,8, 129.0 MHz	PASS	69.2	55.5	13.7
ACR-F (dB)	Pair 7,8-4,5, 749.0 MHz	PASS	56.3	36.0	20.3
PS ACR-F (dB)	Pair 3,6, 369.0 MHz	PASS	59.9	39.2	20.7
RL (dB)	Pair 4,5, 52.5 MHz	PASS	21.4	18.0	3.4
TCL (dB)	Pair 4,5, 87.8 MHz	PASS	30.3	17.0	13.3
CDNEXT (dB)	Pair 7,8-4,5, 1402.0 MHz		42.5		
CMRL (dB)	Pair 4,5, 1644.0 MHz		5.7		
ELTCTL (dB)	Pair 1,2, 2000.0 MHz	PASS	16.9	3.0	13.9
Length (m)	Pair 7,8		23.5		
Prop. Delay (ns)	Pair 3,6	PASS	112	147	35
Delay Skew (ns)	Pair 3,6	PASS	3	9	6
Resistance (ohms)	Pair 3,6	PASS	3.02	6.00	2.98
Resistance Unbalance (ohms)	Pair 1,2	PASS	0.019	0.200	0.181
Resistance P2P Unbalance (ohms)	Pair 3,6-7,8	PASS	0.007	0.200	0.193
Wire Map		PASS			



Issue date

22/06/21

Test Report

TR

170-21

Pag. 27 of 36

Rev. 0



Cable ID: TERA + 1 OCTO CAT8 ISO II P

Test Summary: PASS

Test Limit: ISO11801 PL Class II (+All)

Main: Versiv

Remote: Versiv

Limits Version: V7.6

S/N: 1932179

S/N: 1932375

Date / Time: 06/09/2021 01:46:42 PM

Software Version: V6.6 Build 2

Software Version: V6.6 Build 2

Operator: SIMONE CREMONINI

Calibration Date: 05/14/2020

Calibration Date: 05/12/2020

Headroom 10.5 dB (NEXT 4,5-7,8)

Adapter: DSX-8000 (DSX-PLA-8-TERA)

Adapter: DSX-8000R (DSX-PLA-8-TERA)

Cable Type: Cat 8 S/FTP

S/N: 19470006

S/N: 19470005

NVP: 72.0%

Wire Map	1	2	3	4	5	6	7	8	S
PASS	1	1	1	1	1	1	1	1	1
(T568B)	1	2	3	4	5	6	7	8	S



Length (m)	[Pair 7,8]	23.5
Prop. Delay (ns), Limit 147	[Pair 3,6]	112
Delay Skew (ns), Limit 9	[Pair 3,6]	3
Resistance (ohms), Limit 6.00	[Pair 3,6]	3.02
Resist. Unbal. (ohms), Limit 0.200	[Pair 1,2]	0.019
Resist. P2P Unbal. (ohms), Limit 0.200	[Pair 3,6-7,8]	0.007

Insertion Loss Margin (dB)	[Pair 3,6]	4.4
Frequency (MHz)	[Pair 3,6]	1980.0
Limit (dB)	[Pair 3,6]	25.2

Worst Case Margin Worst Case Value

	MAIN	SR	MAIN	SR
PASS				
Worst Pair	4,5-7,8	4,5-7,8	4,5-7,8	4,5-7,8
NEXT (dB)	10.6	10.5	19.1	19.5
Freq. (MHz)	138.0	137.5	1434.	1498.
Limit (dB)	63.9	63.9	35.5	33.9
Worst Pair	7,8	7,8	7,8	7,8
PS NEXT (dB)	12.5	12.4	27.3	21.6
Freq. (MHz)	138.0	129.0	1992.	1498.
Limit (dB)	60.9	61.4	24.8	30.9

	MAIN	SR	MAIN	SR
PASS				
Worst Pair	7,8-4,5	7,8-4,5	7,8-4,5	7,8-4,5
ACR-F (dB)	20.3	20.3	31.1	30.6
Freq. (MHz)	749.0	738.0	1964.	1860.
Limit (dB)	36.0	36.2	15.1	16.0
Worst Pair	4,5	3,6	1,2	4,5
PS ACR-F (dB)	21.1	20.7	31.9	32.8
Freq. (MHz)	730.0	369.0	2000.	1990.
Limit (dB)	33.3	39.2	11.8	11.9

	MAIN	SR	MAIN	SR
PASS				
Worst Pair	4,5-7,8	4,5-7,8	4,5-7,8	4,5-7,8
ACR-N (dB)	12.1	11.9	32.5	29.0
Freq. (MHz)	138.0	137.5	1994.	1746.
Limit (dB)	57.7	57.8	2.5	6.5
Worst Pair	7,8	7,8	7,8	7,8
PS ACR-N (dB)	13.8	13.7	32.8	34.0
Freq. (MHz)	129.0	129.0	1994.	2000.
Limit (dB)	55.5	55.5	-0.5	-0.6

	MAIN	SR	MAIN	SR
PASS				
Worst Pair	4,5	4,5	7,8	4,5
RL (dB)	3.4	3.5	4.6	7.4
Freq. (MHz)	52.5	52.5	1910.	1960.
Limit (dB)	18.0	18.0	6.5	6.3

Compliant Network Standards:
 10GBASE-T 100GBASE-TX 100GBASE-T4
 1000BASE-T 2.5GBASE-T 5GBASE-T
 10GBASE-T 25GBASE-T 40GBASE-T
 ATM-25 ATM-S1 ATM-155
 100VG-AnyLan TR-4 TR-16 Active

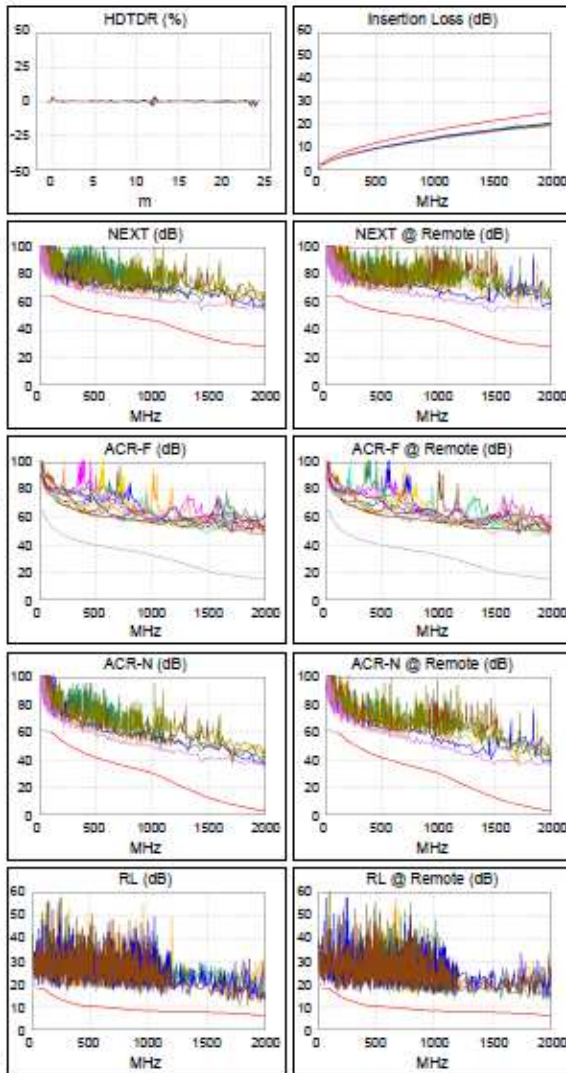

LinkWare™ PC Version 10.7





Issue date

22/06/21

Test Report

TR

170-21

Pag. 28 of 36

Rev. 0



Cable ID: TERA + 1 OCTO CAT8 ISO II P

Test Summary: PASS

Test Limit: ISO11801 PL Class II (+All)
 Limits Version: V7.6
 Date / Time: 06/08/2021 01:46:42 PM
 Operator: SIMONE CREMONINI
 Headroom 10.5 dB (NEXT 4,5-7,8)
 Cable Type: Cat 8 S/FTP
 NVP: 72.0%

Main: Versiv
 S/N: 1932179
 Software Version: V8.6 Build 2
 Calibration Date: 05/14/2020
 Adapter: DSX-8000 (DSX-PLA-8-TERA)
 S/N: 19470006

Remote: Versiv
 S/N: 1932375
 Software Version: V8.6 Build 2
 Calibration Date: 05/12/2020
 Adapter: DSX-8000R (DSX-PLA-8-TERA)
 S/N: 19470005

	Worst Case Margin		Worst Case Value	
	MAIN	SR	MAIN	SR
PASS				
Worst Pair	4,5	1,2	4,5	3,6
TCL (dB)	13,3	13,8	18,8	19,9
Freq. (MHz)	87,8	29,8	1434,	446,0
Limit (dB)	17,0	25,0	3,0	5,0
N/A				
Worst Pair			7,8-4,5	7,8-4,5
CDNEXT (dB)			37,3	42,5
Freq. (MHz)			1434,	1402,
Limit (dB)				
N/A				
Worst Pair			4,5	4,5
CMRL (dB)			3,4	5,7
Freq. (MHz)			1214,	1644,
Limit (dB)				
PASS				
Worst Pair	3,6	1,2	3,6	1,2
ELTCTL (dB)	14,5	13,9	14,5	13,9
Freq. (MHz)	2000,	2000,	2000,	2000,
Limit (dB)	3,0	3,0	3,0	3,0

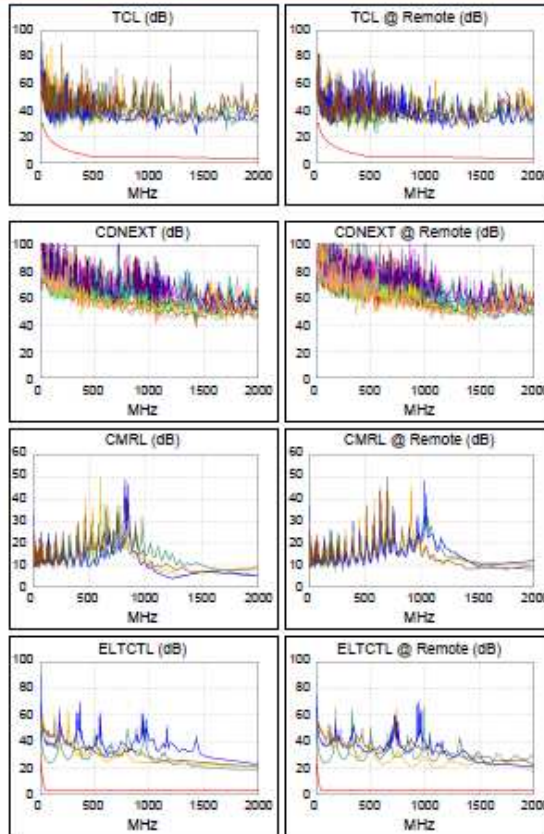

LinkWare™ PC Version 10.7



Issue date 22/06/21

Test Report

TR

170-21

Pag. 29 of 36

Rev. 0

Test on 2 OctoByte connections – ANSI/TIA Cat. 8 Permanent Link



Cable ID: TERA + 2 OCTO CAT8 TIA P

PASS

Cat 8 S/FTP
06/18/2021 04:54 PM

TIA Cat 8 Perm. Link (+All)
DSX-8000

Headroom (NEXT): 26.5 dB
S/N: 1932179

Tests	Detail	Status	Value	Limit	Margin
Insertion Loss (dB)	Pair 4,5, 1934.0 MHz	PASS	22.2	25.7	3.5
NEXT (dB)	Pair 1,2-7,8, 3.9 MHz	PASS	90.5	64.0	26.5
PS NEXT (dB)	Pair 7,8, 3.6 MHz	PASS	90.1	61.2	28.9
ACR-N (dB)	Pair 1,2-7,8, 3.9 MHz	N/A	89.8	61.0	28.8
PS ACR-N (dB)	Pair 7,8, 3.6 MHz	N/A	89.4	58.2	31.2
ACR-F (dB)	Pair 4,5-3,6, 1.0 MHz	PASS	90.8	72.4	18.4
PS ACR-F (dB)	Pair 4,5, 1.0 MHz	PASS	89.1	69.4	19.7
RL (dB)	Pair 4,5, 80.3 MHz	PASS	19.9	18.0	1.9
TCL (dB)	Pair 4,5, 70.8 MHz	PASS	32.3	25.6	6.7
CDNEXT (dB)	Pair 7,8-4,5, 1434.0 MHz		40.2		
CMRL (dB)	Pair 4,5, 1646.0 MHz		5.2		
ELTCTL (dB)	Pair 7,8, 1.0 MHz	PASS	50.0	46.8	3.2
Length (m)	Pair 1,2	PASS	23.5	24.0	0.5
Prop. Delay (ns)	Pair 3,6	PASS	111	136	25
Delay Skew (ns)	Pair 3,6	PASS	2	13	11
Resistance (ohms)	Pair 3,6	PASS	2.99	5.60	2.61
Resistance Unbalance (ohms)	Pair 1,2	PASS	0.014	0.100	0.086
Resistance P2P Unbalance (ohms)	Pair 3,6-7,8	PASS	0.009	0.200	0.191
Wire Map		PASS			



Issue date

22/06/21

Test Report

TR

170-21

Pag. 30 of 36

Rev. 0



Cable ID: TERA + 2 OCTO CAT8 TIA P

Test Summary: PASS

Test Limit: TIA Cat 8 Perm. Link (+All)
 Limits Version: V7.6
 Date / Time: 06/18/2021 04:54:15 PM
 Operator: SIMONE CREMONINI
 Headroom 26.5 dB (NEXT 1,2-7,8)
 Cable Type: Cat 8 S/FTP
 NVP: 72.0%

Main: Versiv
 S/N: 1932179
 Software Version: V6.6 Build 2
 Calibration Date: 05/14/2020
 Adapter: DSX-8000 (DSX-PLA-8-TERA)
 S/N: 19470006

Remote: Versiv
 S/N: 1932375
 Software Version: V6.6 Build 2
 Calibration Date: 05/12/2020
 Adapter: DSX-8000R (DSX-PLA-8-TERA)
 S/N: 19470005

Wire Map	1 2 3 4 5 6 7 8 S
PASS	1 1 1 1 1 1 1 1 1
(T568B)	1 2 3 4 5 6 7 8 S



Length (m), Limit 24.0	[Pair 1,2]	23.5
Prop. Delay (ns), Limit 136	[Pair 3,6]	111
Delay Skew (ns), Limit 13	[Pair 3,6]	2
Resistance (ohms), Limit 5.60	[Pair 3,6]	2.99
Resist Unbal. (ohms), Limit 0.100	[Pair 1,2]	0.014
Resist P2P Unbal. (ohms), Limit 0.200	[Pair 3,6-7,8]	0.009
Insertion Loss Margin (dB)	[Pair 4,5]	3.5
Frequency (MHz)	[Pair 4,5]	1934.0
Limit (dB)	[Pair 4,5]	25.7

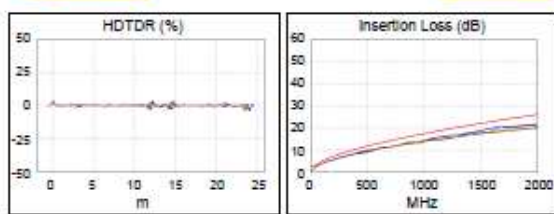

	Worst Case Margin		Worst Case Value	
PASS	MAIN	SR	MAIN	SR
Worst Pair	1,2-7,8	1,2-7,8	4,5-7,8	1,2-3,6
NEXT (dB)	30.1	26.5	43.3	35.1
Freq. (MHz)	3.5	3.9	1980.	1718.
Limit (dB)	64.7	64.0	10.0	12.0
Worst Pair	4,5	7,8	7,8	1,2
PS NEXT (dB)	31.0	28.9	45.7	38.8
Freq. (MHz)	1.0	3.6	1982.	1718.
Limit (dB)	62.0	61.2	6.1	8.2

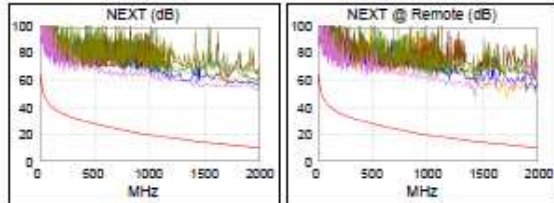

PASS	MAIN	SR	MAIN	SR
Worst Pair	4,5-3,6	3,6-4,5	7,8-4,5	7,8-4,5
ACR-F (dB)	18.4	18.4	38.6	39.1
Freq. (MHz)	1.0	1.0	1968.	1968.
Limit (dB)	72.4	72.4	6.5	6.5
Worst Pair	4,5	4,5	4,5	3,6
PS ACR-F (dB)	20.7	19.7	40.0	40.2
Freq. (MHz)	1.0	1.0	1968.	1938.
Limit (dB)	69.4	69.4	3.5	3.6

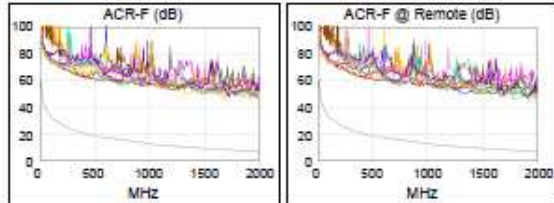

N/A	MAIN	SR	MAIN	SR
Worst Pair	1,2-7,8	1,2-7,8	4,5-7,8	1,2-3,6
ACR-N (dB)	32.4	28.8	49.5	37.8
Freq. (MHz)	4.4	3.9	1982.	1718.
Limit (dB)	60.2	61.0	-16.1	-11.9
Worst Pair	3,6	7,8	4,5	3,6
PS ACR-N (dB)	33.3	31.2	50.5	41.6
Freq. (MHz)	4.1	3.6	1980.	1718.
Limit (dB)	57.3	58.2	-19.9	-15.7

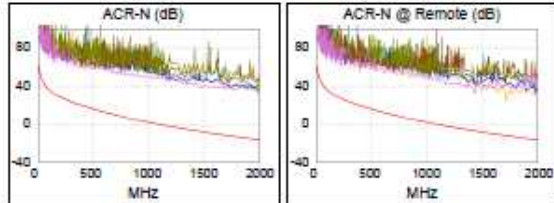

PASS	MAIN	SR	MAIN	SR
Worst Pair	4,5	4,5	4,5	4,5
RL (dB)	2.4	1.9	4.7	4.5
Freq. (MHz)	80.0	80.3	1960.	1632.
Limit (dB)	18.0	18.0	8.0	8.0

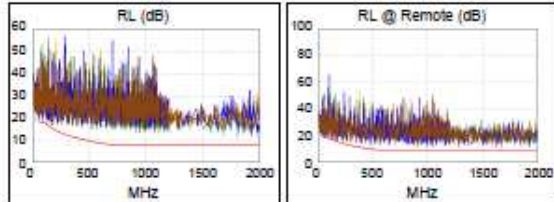

Compliant Network Standards:
 10BASE-T 100BASE-TX 100BASE-T4
 1000BASE-T 2.5GBASE-T 5GBASE-T
 10GBASE-T 25GBASE-T 40GBASE-T
 ATM-25 ATM-S1 ATM-155
 100GBase Ethernet TR-4 TR-16 Active

LinkWare™ PC Version 10.6.1

Project: 170-21
 Test: 170-21-1
 Cat8 Test 2.rtf





Issue date

22/06/21

Test Report

TR

170-21

Pag. 31 of 36

Rev. 0



Cable ID: TERA + 2 OCTO CAT8 TIA P

Test Limit: TIA Cat 8 Perm. Link (+All)

Limits Version: V7.6

Date / Time: 06/18/2021 04:54:15 PM

Operator: SIMONE CREMONINI

Headroom 26.5 dB (NEXT 1,2-7,8)

Cable Type: Cat 8 S/FTP

NVP: 72.0%

Main: Versiv

S/N: 1932179

Software Version: V8.6 Build 2

Calibration Date: 05/14/2020

Adapter: DSX-8000 (DSX-PLA-8-TERA)

S/N: 19470006

Test Summary: PASS

Remote: Versiv

S/N: 1932375

Software Version: V8.6 Build 2

Calibration Date: 05/12/2020

Adapter: DSX-8000R (DSX-PLA-8-TERA)

S/N: 19470005

	Worst Case Margin		Worst Case Value	
PASS	MAIN	SR	MAIN	SR
Worst Pair	4.5	1.2	1.2	1.2
TCL (dB)	6.7	6.8	11.6	9.1
Freq. (MHz)	70.8	25.5	372.0	370.0
Limit (dB)	25.6	33.1	13.3	13.3
N/A	MAIN	SR	MAIN	SR
Worst Pair			7.8-4.5	7.8-4.5
CDNEXT (dB)			40.2	36.6
Freq. (MHz)			1434.	1434.
Limit (dB)				
N/A	MAIN	SR	MAIN	SR
Worst Pair			4.5	4.5
CMRL (dB)			3.4	5.2
Freq. (MHz)			1886.	1646.
Limit (dB)				
PASS	MAIN	SR	MAIN	SR
Worst Pair	7.8	7.8	3.5	1.2
ELTCTL (dB)	6.2	3.2	14.4	14.6
Freq. (MHz)	1.0	1.0	2000.	1988.
Limit (dB)	46.8	46.8	3.0	3.0

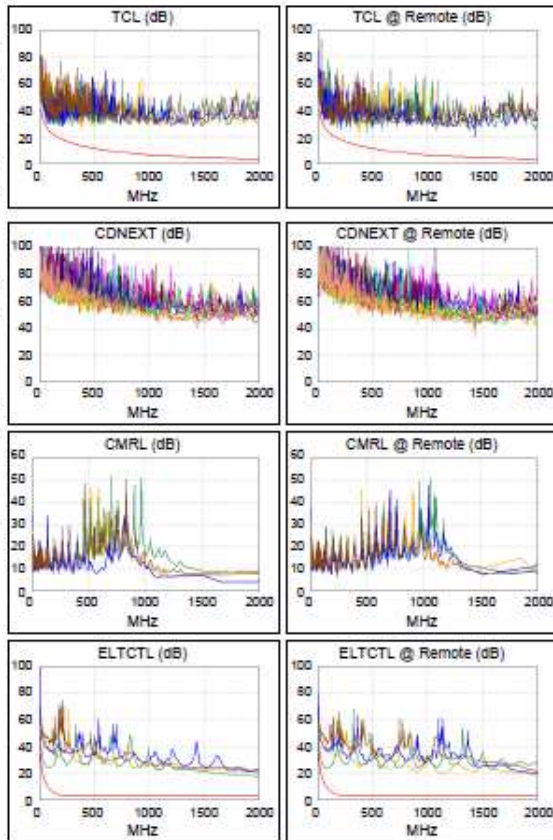

LinkWare™ PC Version 10.8.1



Issue date

22/06/21

Test Report

TR

170-21

Pag. 32 of 36

Rev. 0

Test on 2 Octo byte connections – ISO/IEC 11801 Cat. II Permanent Link 2



Cable ID: TERA + 2 OCTO CAT8 ISO			PASS		
Cat 8 S/FTP		ISO11801 PL Class II (+All)	Headroom (NEXT): 8.8 dB		
06/18/2021 04:55 PM		DSX-8000	S/N: 1932179		
Tests	Detail	Status	Value	Limit	Margin
Insertion Loss (dB)	Pair 4,5, 1934.0 MHz	PASS	22.2	24.9	2.7
NEXT (dB)	Pair 4,5-7,8, 129.0 MHz	PASS	73.2	64.4	8.8
PS NEXT (dB)	Pair 4,5, 129.0 MHz	PASS	72.1	61.4	10.7
ACR-N (dB)	Pair 4,5-7,8, 129.0 MHz	PASS	68.6	58.5	10.1
PS ACR-N (dB)	Pair 4,5, 129.0 MHz	PASS	67.4	55.5	11.9
ACR-F (dB)	Pair 7,8-4,5, 745.0 MHz	PASS	55.9	36.1	19.8
PS ACR-F (dB)	Pair 4,5, 737.0 MHz	PASS	53.6	33.2	20.4
RL (dB)	Pair 4,5, 80.3 MHz	PASS	19.9	18.0	1.9
TCL (dB)	Pair 4,5, 70.8 MHz	PASS	32.3	18.6	13.7
CDNEXT (dB)	Pair 7,8-4,5, 1434.0 MHz		40.7		
CMRL (dB)	Pair 4,5, 1650.0 MHz		5.2		
ELTCTL (dB)	Pair 3,6, 2000.0 MHz	PASS	17.4	3.0	14.4
Length (m)	Pair 1,2		23.5		
Prop. Delay (ns)	Pair 3,6	PASS	111	147	36
Delay Skew (ns)	Pair 3,6	PASS	2	9	7
Resistance (ohms)	Pair 3,6	PASS	3.00	6.00	3.00
Resistance Unbalance (ohms)	Pair 1,2	PASS	0.010	0.200	0.190
Resistance P2P Unbalance (ohms)	Pair 3,6-7,8	PASS	0.009	0.200	0.191
Wire Map		PASS			



Issue date

22/06/21

Test Report

TR

170-21

Pag. 33 of 36

Rev. 0



Cable ID: TERA + 2 OCTO CAT8 ISO

Test Summary: PASS

Test Limit: ISO11801 PL Class II (+All)
 Limits Version: V7.6
 Date / Time: 06/18/2021 04:55:36 PM
 Operator: SIMONE CREMONINI
 Headroom 8.8 dB (NEXT 4,5-7,8)
 Cable Type: Cat 8 S/FTP
 NVP: 72.0%

Main: Versiv
 S/N: 1932179
 Software Version: V6.6 Build 2
 Calibration Date: 05/14/2020
 Adapter: DSX-8000 (DSX-PLA-8-TERA)
 S/N: 19470006

Remote: Versiv
 S/N: 1932375
 Software Version: V6.6 Build 2
 Calibration Date: 05/12/2020
 Adapter: DSX-9000R (DSX-PLA-8-TERA)
 S/N: 19470005

Wire Map	1 2 3 4 5 6 7 8 8
PASS	1 1 1 1 1 1 1 1 1
(T568B)	1 2 3 4 5 6 7 8 8

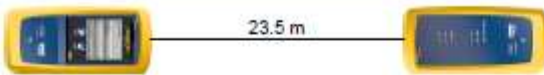

Length (m)	[Pair 1,2]	23.5
Prop. Delay (ns), Limit 147	[Pair 3,6]	111
Delay Skew (ns), Limit 9	[Pair 3,6]	2
Resistance (ohms), Limit 6.00	[Pair 3,6]	3.00
Resist. Unbal. (ohms), Limit 0.200	[Pair 1,2]	0.010
Resist. P2P Unbal. (ohms), Limit 0.200	[Pair 3,6-7,8]	0.009
Insertion Loss Margin (dB)	[Pair 4,5]	2.7
Frequency (MHz)	[Pair 4,5]	1934.0
Limit (dB)	[Pair 4,5]	24.9

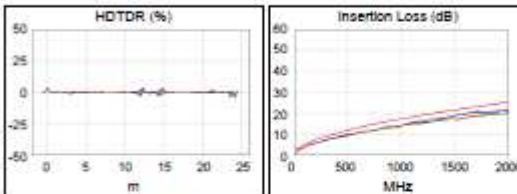

	MAIN	SR	MAIN	SR
PASS				
Worst Pair	4,5-7,8	4,5-7,8	4,5-7,8	1,2-3,6
NEXT (dB)	9.6	8.8	25.5	18.8
Freq. (MHz)	129.5	129.0	1982.	1718.
Limit (dB)	64.4	64.4	27.8	30.3
Worst Pair	7,8	4,5	7,8	1,2
PS NEXT (dB)	11.4	10.7	26.9	19.5
Freq. (MHz)	129.5	129.0	1982.	1718.
Limit (dB)	61.4	61.4	24.8	27.3

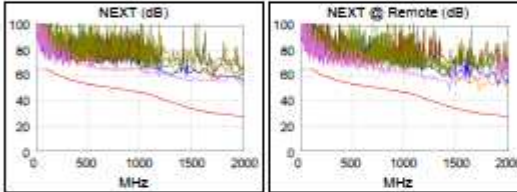

	MAIN	SR	MAIN	SR
PASS				
Worst Pair	7,8-4,5	4,5-7,8	7,8-4,5	7,8-4,5
ACR-F (dB)	19.8	19.9	29.8	30.5
Freq. (MHz)	745.0	746.0	1968.	1968.
Limit (dB)	36.1	36.1	15.1	15.1
Worst Pair	4,5	3,6	4,5	3,6
PS ACR-F (dB)	20.4	20.6	31.2	32.1
Freq. (MHz)	737.0	412.0	1968.	1930.
Limit (dB)	33.2	38.2	12.1	12.4

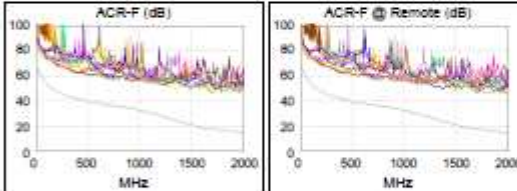

	MAIN	SR	MAIN	SR
PASS				
Worst Pair	4,5-7,8	4,5-7,8	4,5-7,8	1,2-3,6
ACR-N (dB)	11.0	10.1	30.8	18.8
Freq. (MHz)	129.5	129.0	1982.	1720.
Limit (dB)	58.4	58.5	2.6	6.9
Worst Pair	4,5	4,5	4,5	3,6
PS ACR-N (dB)	12.8	11.9	31.0	21.8
Freq. (MHz)	129.0	129.0	1978.	1720.
Limit (dB)	55.5	55.5	-0.3	3.9

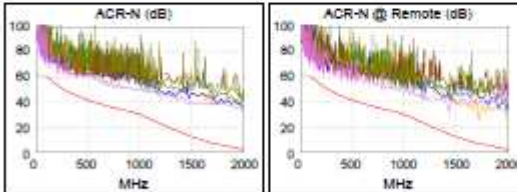

	MAIN	SR	MAIN	SR
PASS				
Worst Pair	4,5	4,5	4,5	4,5
RL (dB)	2.4	1.9	6.2	4.8
Freq. (MHz)	80.0	80.3	1960.	1632.
Limit (dB)	18.0	18.0	6.3	7.8

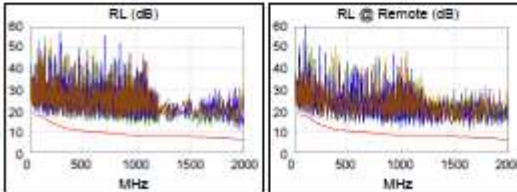

Compliant Network Standards:
 10GBASE-T, 100GBASE-TX, 100GBASE-T4
 100GBASE-T, 2.5GBASE-T, 5GBASE-T
 10GBASE-T, 25GBASE-T, 40GBASE-T
 ATM-25, ATM-51, ATM-155
 TR-4, TR-16 Active

LinkWare™ PC Version 10.6.1

Project: CAT8.1
 Cable Test: 21W





Issue date

22/06/21

Test Report

TR

170-21

Pag. 34 of 36

Rev. 0



Cable ID: TERA + 2 OCTO CAT8 ISO

Test Limit: ISO11801 PL Class II (+All)
 Limits Version: V7.6
 Date / Time: 06/18/2021 04:55:36 PM
 Operator: SIMONE CREMONINI
 Headroom 8.8 dB (NEXT 4,5-7,8)
 Cable Type: Cat 8 S/FTP
 NVP: 72.0%

Main: Versiv
 S/N: 1932179
 Software Version: V6.6 Build 2
 Calibration Date: 05/14/2020
 Adapter: DSX-8000 (DSX-PLA-8-TERA)
 S/N: 19470006

Test Summary: PASS

Remote: Versiv
 S/N: 1932375
 Software Version: V6.6 Build 2
 Calibration Date: 05/12/2020
 Adapter: DSX-8000R (DSX-PLA-8-TERA)
 S/N: 19470005

	Worst Case Margin		Worst Case Value	
	MAIN	SR	MAIN	SR
PASS				
Worst Pair	4,5	1,2	1,2	1,2
TCL (dB)	13.7	13.8	18.4	16.1
Freq. (MHz)	70.8	25.3	372.0	370.0
Limit (dB)	18.6	26.2	6.3	6.3
N/A				
Worst Pair			7,8-4,5	7,8-4,5
CDNEXT (dB)			40.7	36.4
Freq. (MHz)			1434.	1434.
Limit (dB)				
N/A				
Worst Pair			4,5	4,5
CMRL (dB)			3.4	5.2
Freq. (MHz)			1886.	1650.
Limit (dB)				
PASS				
Worst Pair	3,6	1,2	3,6	1,2
ELTCTL (dB)	14.4	15.6	14.4	15.6
Freq. (MHz)	2000.	1996.	2000.	1996.
Limit (dB)	3.0	3.0	3.0	3.0

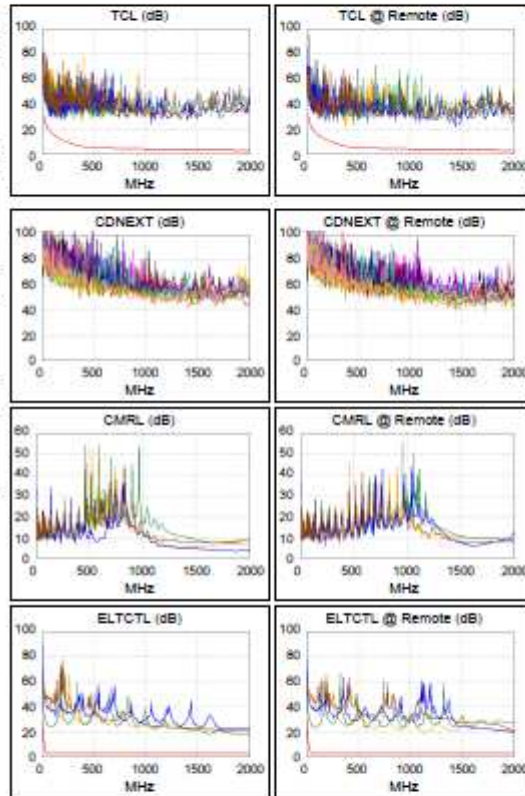

LinkWare™ PC Version 10.8.1





Issue date

22/06/21

Test Report

TR

170-21

Pag. 35 of 36

Rev. 0

HDTDx – 2 OctoByte Connection

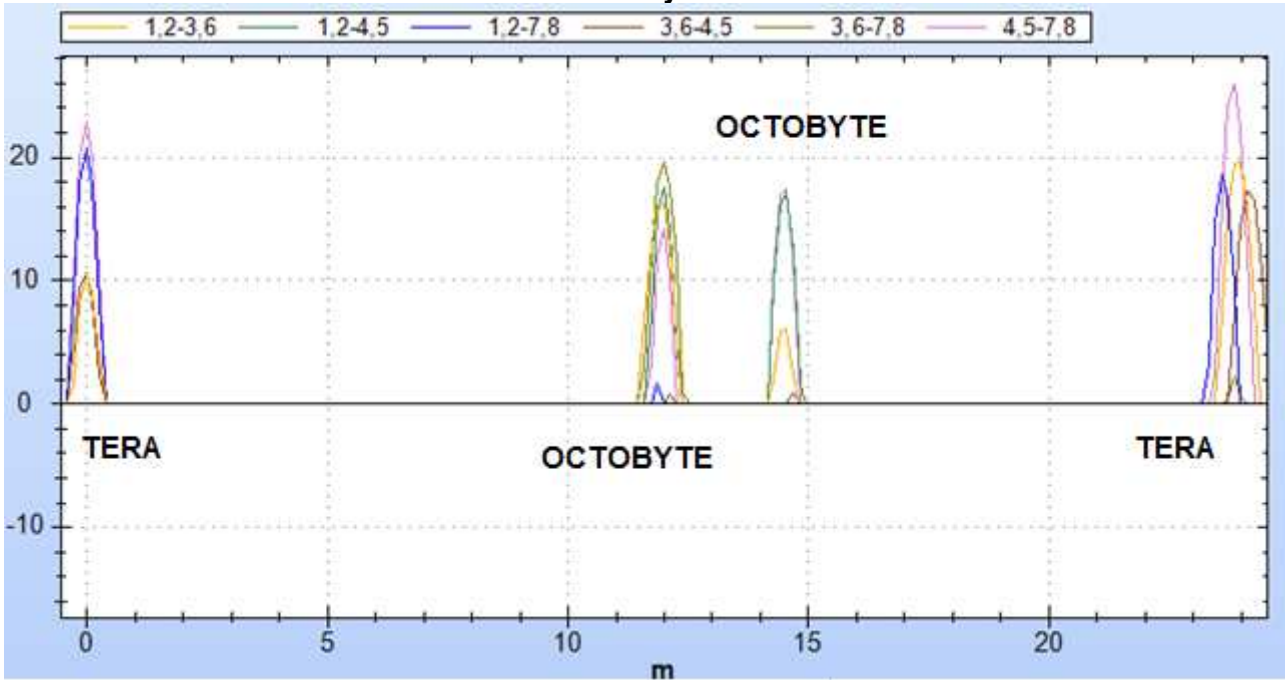

HDTDdR – 2 OctoByte Connection

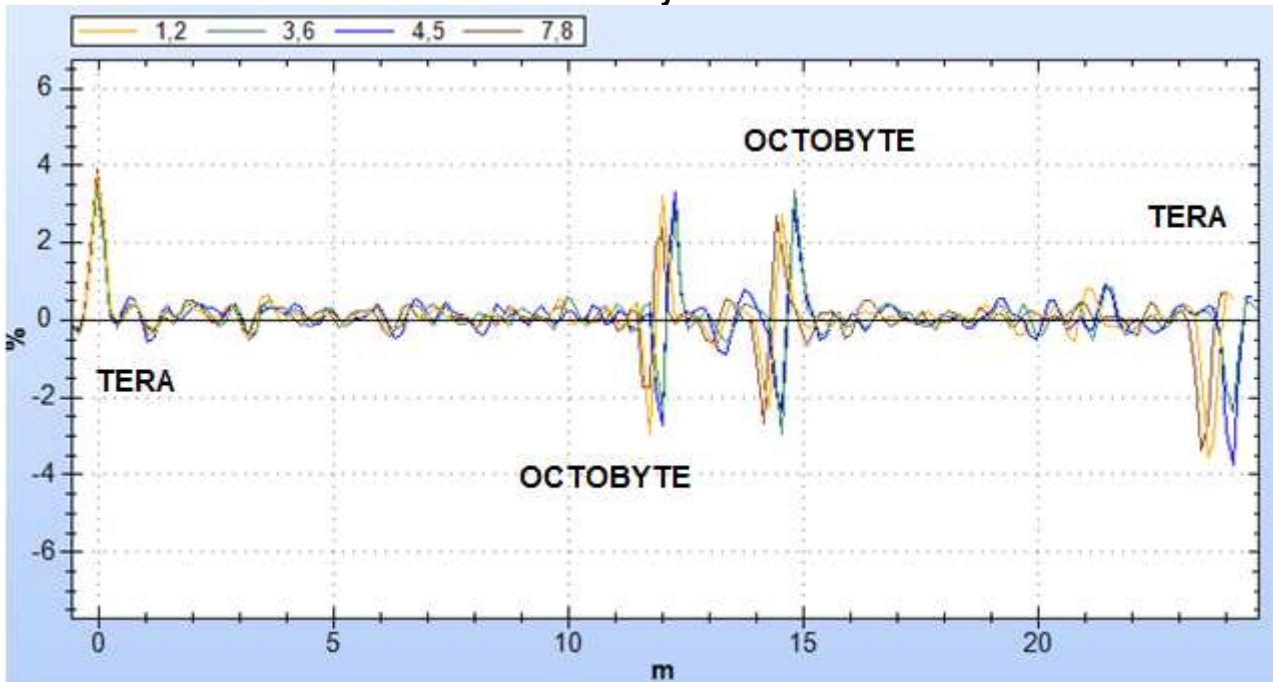

	Issue date	22/06/21
	Test Report	
	TR	170-21
	Pag. 36 of 36	Rev. 0

1.8. Comments / remarks – commenti / osservazioni

Test	Cable	1 Octobyte connection	2 Octobyte connections
TIA/EIA 568 CAT 8 Permanent Link	PASS	PASS	PASS
ISO11801 Class II Permanent Link 2	PASS	PASS	PASS