

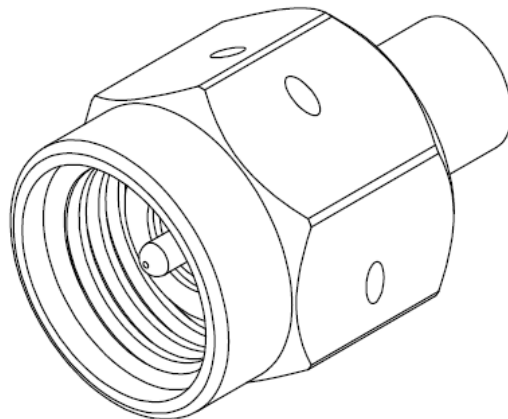

# GT-25-158

COAX CONNECTOR, 2.92 MM MALE  
GRF01-0301-2.92-MS-160 FOR CABLE 962-048-160  
RF Signal Integrity Report





## Revision History

Rev	Date	Issued	Approved	Description
1	8/21/2025	L. Blackwell	G. Hunziker	Initial Release

## Table of Contents

1. Introduction .....	3
2. Test Information .....	3
2.1. Test Samples .....	3
2.2. Test Setup .....	3
3. Test Results .....	4
3.1.1. Connector Insertion Loss .....	4
3.1.2. Connector VSWR .....	5

## Table of Figures

Figure 1. GRF01-0301-2.92-MS-160 Test Article .....	3
Figure 2. Connector Insertion Loss .....	4
Figure 3. Connector VSWR .....	5

## 1. Introduction

This document contains results from testing that was performed to evaluate the high-frequency electrical performance of the Glenair 2.92 mm male connector, part number GRF01-0301-2.92-MS-160. This report outlines the frequency domain performances of Insertion Loss (IL) and Voltage Standing Wave Ratio (VSWR).

## 2. Test Information

### 2.1. Test Samples

Test samples consisted of GRF01-0301-2.92-MS-160 connectors terminated to Glenair cable 962-048-160.



Figure 1. GRF01-0301-2.92-MS-160 Test Article

### 2.2. Test Setup

Measurements were taken using an Anritsu MS46524B Vector Network Analyzer. No test fixturing was required as the test samples are directly connected to the test equipment. The test data was saved in a touchstone (.s2p) format.

### 3. Test Results

#### 3.1.1. Connector Insertion Loss

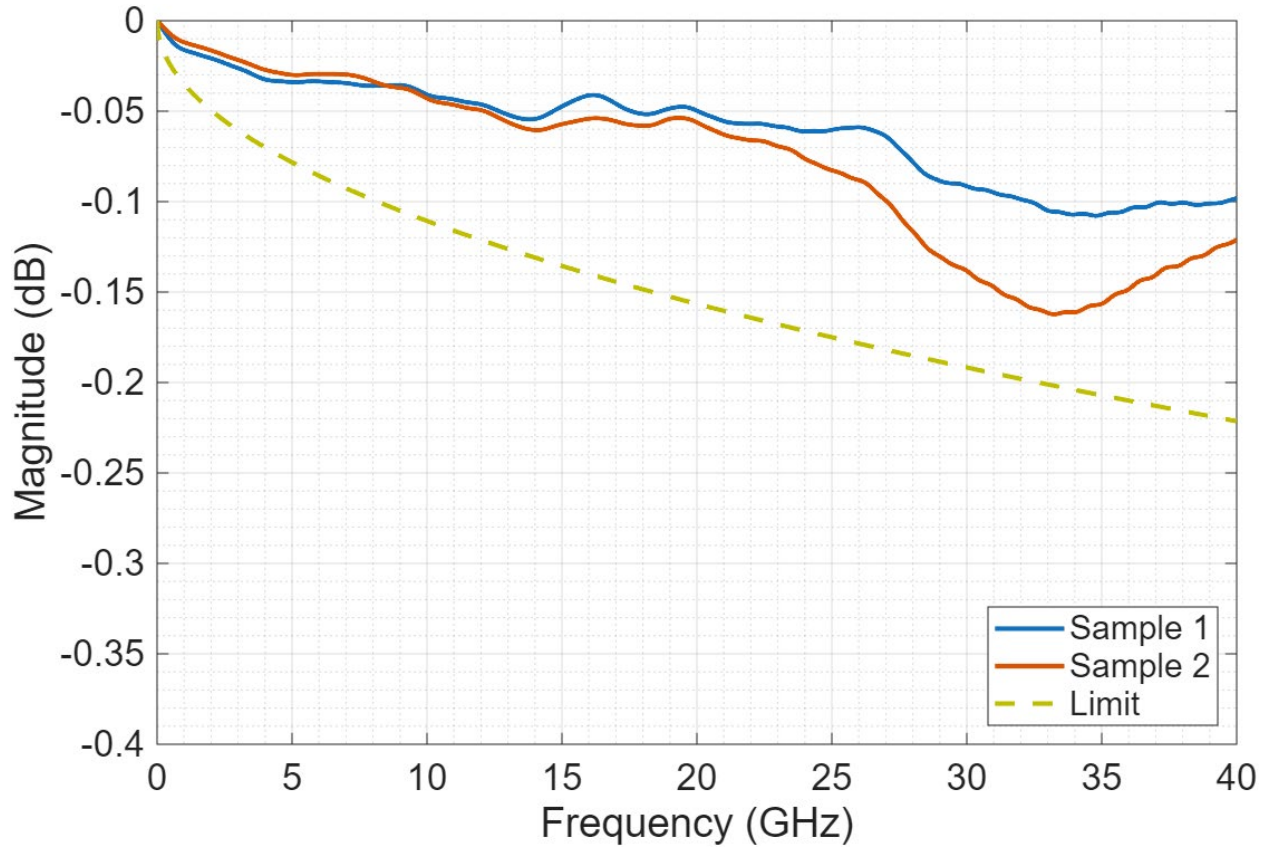

Figure 2. Connector Insertion Loss

### 3.1.2. Connector VSWR

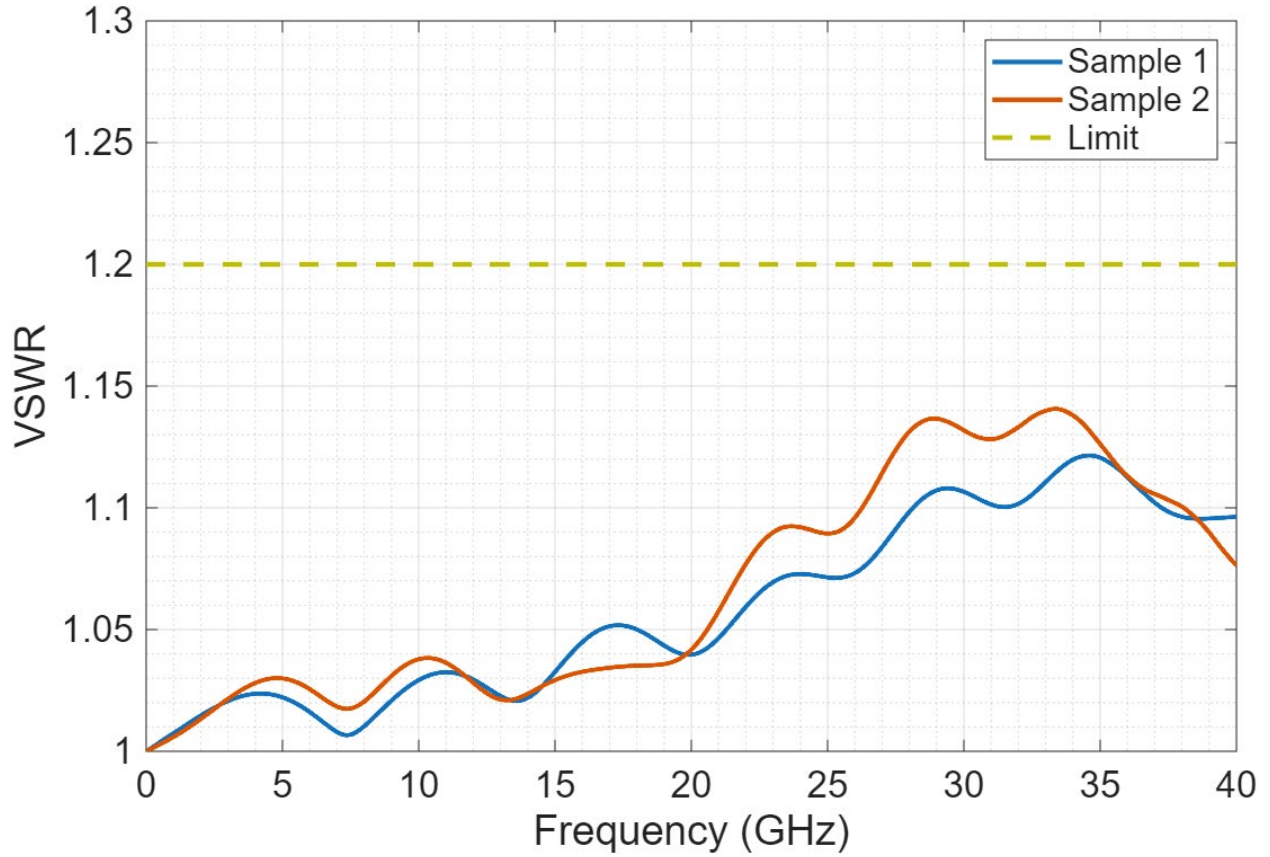

Figure 3. Connector VSWR