

# MIL-PRF-24758-49

## User Installable Backshell

### with Band Termination Porch to MIL-PRF-24758 Conduit

A

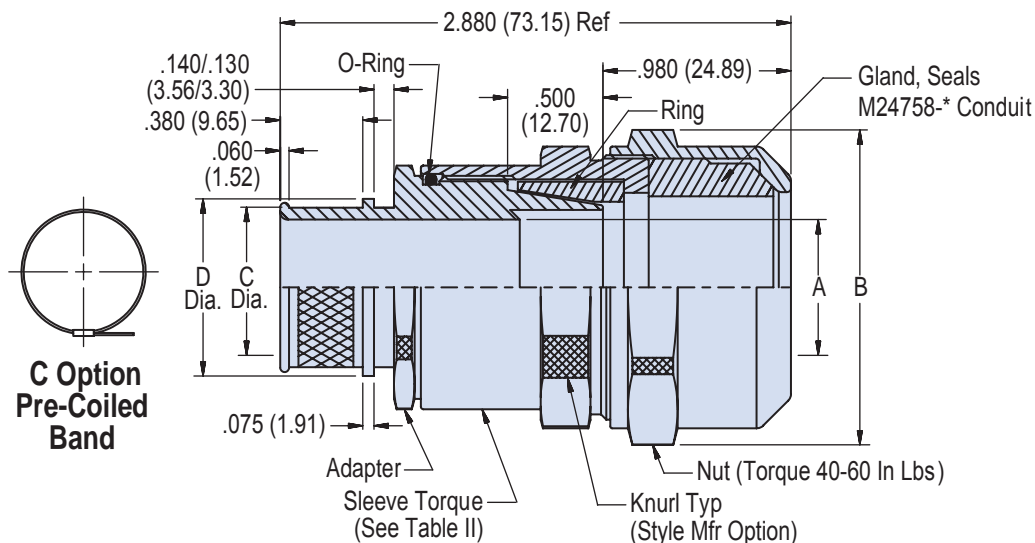
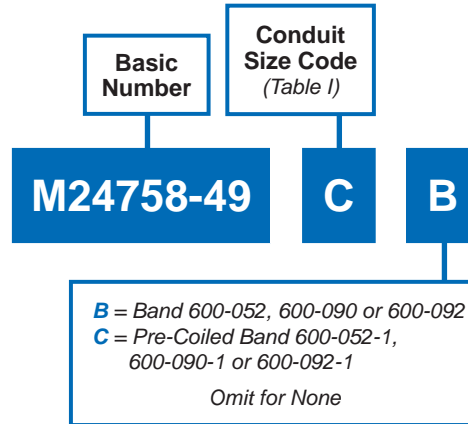

### APPLICATION NOTES

- Assembly identified with manufacturer's name, code I.D. number, part number and classification code 490, space permitting.
- Glenair 600 Series Backshell Assembly Tools are recommended for assembly and installation.
- Material / Finish:  
Coupling nuts, adapters, nuts, sleeves, elbows and rings - 316L SST/  
Electroless nickel, matte finish.  
O-Ring and gland - Silicone rubber/NA
- Metric dimensions (mm) are indicated in parentheses.

**MIL-PRF-24758-49**  
**User Installable Backshell**  
 with Band Termination Porch to MIL-PRF-24758 Conduit



MIL-PRF  
24758A

A

**TABLE I: CONDUIT SIZE CODE & DIMENSIONS**

Conduit Size Code	A I.D.	B MAX	C DIA.	D DIA.
A	.250 (6.35)	1.18 (29.97)	.375 (9.53)	.531 (13.49)
B	.500 (12.70)	1.45 (36.83)	.625 (15.88)	.750 (19.05)
C	.750 (19.05)	1.79 (45.47)	.875 (22.23)	1.000 (25.40)
D	1.000 (25.40)	2.06 (52.32)	1.125 (28.58)	1.250 (31.75)
E	1.250 (31.75)	2.32 (58.93)	1.375 (34.93)	1.500 (38.10)
F	1.500 (38.10)	2.59 (65.79)	1.625 (41.28)	1.750 (44.45)
G	2.000 (50.80)	3.26 (82.80)	2.125 (53.98)	2.250 (57.15)
H	2.500 (63.50)	3.80 (96.52)	2.625 (66.68)	2.750 (69.85)
J	.375 (9.53)	1.32 (33.53)	.500 (12.70)	.625 (15.88)
K	.625 (15.88)	1.66 (42.16)	.750 (19.05)	.875 (22.23)
L	3.000 (76.20)	4.34 (110.24)	3.125 (79.38)	3.250 (82.55)

**TABLE II:  
Recommended  
Sleeve Torque**

Conduit Size Code	±5 Inch Pounds
A	120
B	140
C	150
D	170
E	170
F	170
G	170
H	170
J	120
K	140
L	170