

GRF05-0004 50 Ohm BNC Series Socket Bulkhead Feedthrough Connector



HOW TO ORDER			
Sample Part Number		GRF05-0004	-1 Z1
Series	GRF05-0004 = GRF triax hermetic adapter		
Keying (Both Ends)	-1 = .4375-28 UNEF-2A Thd		
	-2 = 2 Lug Bayonet		
	-3 = 3 Lug Bayonet		
Finish	Z1 = Stainless steel / passivate		
	ZL = Stainless steel / nickel		
	Z3 = Silver Plate		

MATERIAL AND FINISH

- Body, jam nut: CRES/see part number development
- Intermediate contact and center pin contact (glass sealed section) - nickel-iron and nickel alloy / gold plated
- Center socket contact (mating ends): BeCu/gold plated alloy
- Insulator: fused vitreous glass/N.A. PTFE/N.A.
- Sealing gasket: Fluorosilicone/N.A.

SPECIFICATIONS

- Frequency range: DC to 4 Ghz
- Insertion loss: -.157 dB min
- VSWR: 1.25 max
- Hermeticity: 1×10^{-7} cc/sec of helium at one atmosphere Delta P
- Insulation resistance: greater than 5000 MegOhms
- DWV: 1200 VAC between center contact and intermediate contact, 500VAC between intermediate contact and outer body
- Operating temperature: -65°C to +200°C

NOTES

- With bayonet or threaded coupling (see part number development).

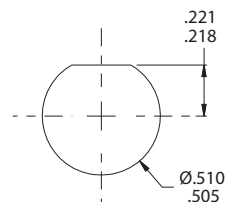
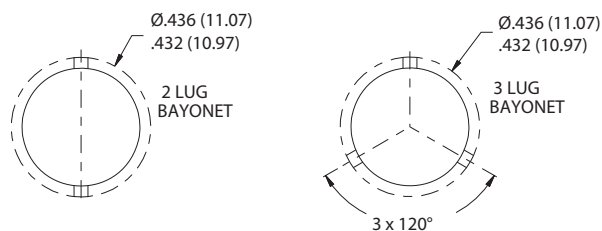
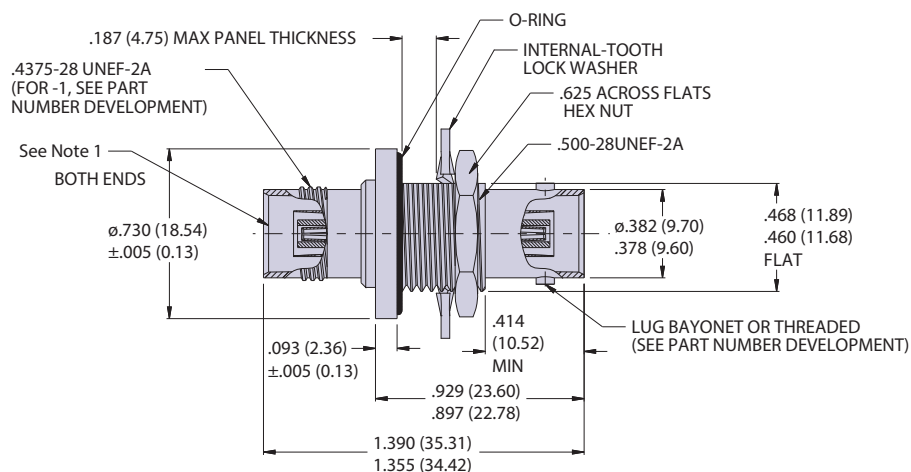

RECOMMENDED MOUNTING HOLE

CONTACT JUMPER AND CONNECTOR ASSEMBLIES