

GRF01-0007 50 Ohm BNC Series Socket Bulkhead Feedthrough Connector



HOW TO ORDER	
Sample Part Number	GRF01-0007
Series	GRF01-0007 = GRF triax hermetic adapter

MATERIAL AND FINISH

- Shell: stainless steel 304L / passivated
- Mounting nut, washer: stainless steel 303 / passivated
- Hermetic seal contact: alloy 52 / gold plated
- Front socket and rear contacts: copper alloy / gold Plated
- Insulator: PTFE / N.A.
- Fused vitreous glass / N.A.
- O-ring: fluorosilicone per MIL-DTL-25988 or equivalent / N.A.

SPECIFICATIONS

- Temperature range: -65°C to +125°C
- Hermeticity: < 1 x 10⁻⁷ cc/sec of helium at one atmosphere Delta P.
- Impedance: 50 ohms nom.
- Frequency range: DC-10 Ghz
- VSWR: 1.20:1 DC to 3 Ghz
- Insertion loss: .2 dB, DC to 3 Ghz
- DWV: 1000 VRMS at sea level
- IR: 5000 megohms minimum, room temperature

NOTES

1. Connector is designed for 50 Ohm cable see table I
2. Connector interface per Mil-STD-348, Series SMA, Socket contact"

CABLES ACCOMODATED

- M17/113-RG316
- M17/119-RG174
- M17/138-00001
- M17/217-00001
- RG188

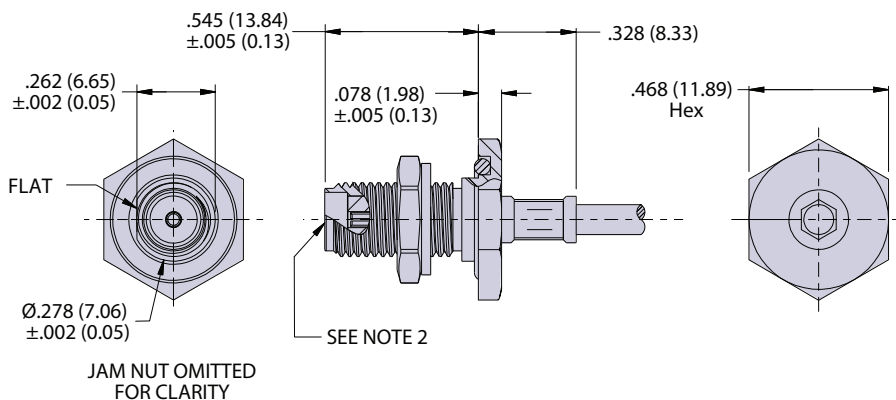
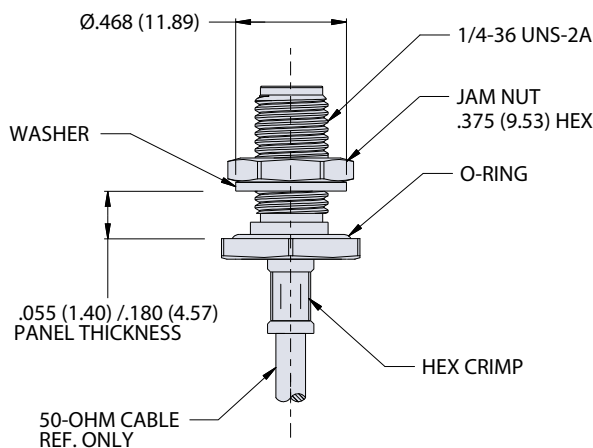

CONTACT JUMPER AND CONNECTOR ASSEMBLIES