

Series 79 Micro-Crimp®



799-164

Piggyback EMI Banding Backshell, Series 792

- Split Piggyback for Series 792
- Band-Master® Shield Termination
- For High-Speed Data Cables



799-164

This accessory fits Series 792 connectors with twinax, quadrax or El Ochito contacts:
792-001, 792-002

EMI, piggyback, split. 799-164 piggyback backshell fits Series 792 connectors with rear groove on shell. Backshell has internal fluorosilicone wire strain relief grommet. Grommet has three hole sizes to accommodate twinax, quadrax or octaxial high speed cables. Available with Qwik-Ty strain relief arm or slots for lacing tape. Terminate cable shield to backshell with BandMaster ATS band strap. Aluminum with stainless steel screws. Non-environmental.

799-164 INTERNAL VIEW

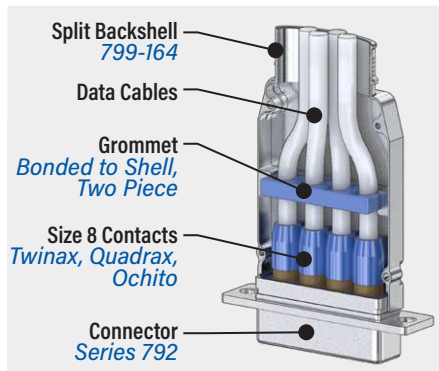

Shell Size	A Max		B Max		Height	
	in	mm	in	mm	in	mm
A	.575	14.6	.810	20.6	2.380	60.5
B	.575	14.6	1.185	30.1	2.500	63.5
C	.575	14.6	1.560	39.6	2.940	74.7
D	.575	14.6	1.935	49.1	3.120	79.2
E	.575	14.6	2.310	58.7	3.310	84.1
F	.950	24.1	2.310	58.7	3.380	85.9

PART NUMBER	
Sample PN →	799-164 M D N N N 2
Base P/N	799-164
Material / Finish	TZ Alum / Tin-Zinc M Alum / Electroless Nickel MT Alum / Nickel-PTFE ZR Alum / Black Zinc-Nickel
Shell Size	A B C D E F
Band	N No Band B Standard Band Incl. S Slim Std. Band Incl. M Micro Band Included J Micro Slim Band Included L Micro-Max Band Included
Qwik-Ty	T Qwik-Ty Strain Relief Arm N No Qwik-Ty
Lace-Tie Option	H Holes for Lace-Tie S Slots for Lace-Tie N No Lace-Tie Provision
Cable Size	1 .188 (4.8) Max. Individual Cable Diameter 2 .250 (6.4) Max. Individual Cable Diameter 3 .313 (8.0) Max. Individual Cable Diameter

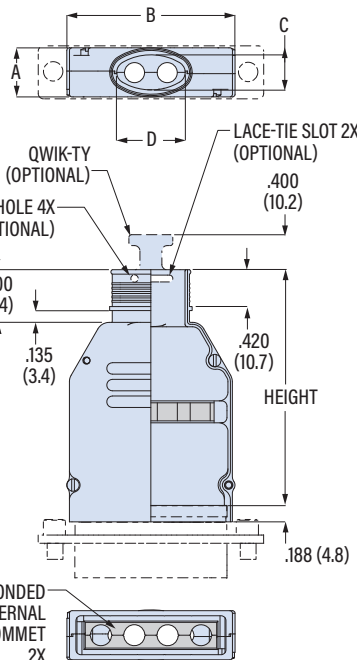

ENTRY SIZE 1

Shell Size	C in	C mm	D in	D mm
A	.200	5.1	.300	7.6
B	.250	6.4	.390	9.9
C	.400	10.2	.440	11.2
D	.400	10.2	.520	13.2
E	.400	10.2	.690	17.5
F	.700	17.8	.700	17.8

ENTRY SIZE 2

Shell Size	C in	C mm	D in	D mm
A	.260	6.6	.360	9.1
B	.340	8.6	.510	13.0
C	.400	10.2	.740	18.8
D	.400	10.2	.960	24.4
E	.400	10.2	1.170	29.7
F	.775	19.7	.775	19.7

ENTRY SIZE 3

Shell Size	C in	C mm	D in	D mm
A	.320	8.1	.420	10.7
B	.380	9.7	.630	16.0
C	.400	10.2	.940	23.9
D	.400	10.2	1.250	31.8
E	.400	10.2	1.550	39.4
F	.775	19.7	1.650	41.9

Band Type and Width	Hand Tool	Pneumatic
Standard: .24 (6.1)	601-100	601-106
Slim Standard: .24 (6.1)	601-109	601-110
Micro: .12 (3.0)	601-101	601-107
Micro Slim: .12 (3.0)	601-122	601-123
Micro-Max: .12 (3.0)	601-129	601-118

SERIES 79 MICRO-CRIMP ACCESSORIES