

# DPX / AS81659



## 527-476

### Backshell, EMI Banding, AS81659/ DPXB

- Composite Split
- Band-Master ATS Shield Termination



### 527-476

Split EMI backshell fits AS81659 connectors

Lightweight composite material. Terminate cable braid shield to backshell with **Band-Master ATS®** banding strap. Options include slots for individual wire shields and Qwik-Ty arm.

Thermoplastic with stainless steel hardware and aluminum mesh/neoprene gasket.

### FIGURE 1 POLYSULFIDE OPTION

TERMINATION AREAS  
FREE OF CADMIUM

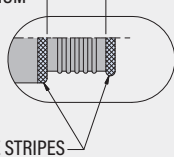

POLYSULFIDE STRIPES  
POLYSULFIDE OPTION IS AVAILABLE  
FOR FINISH CODE XW ONLY

### BAND OPTIONS

Terminate cable braid to backshell with optional band strap and banding tool. Pre-coiled bands are passivated stainless steel. Slim Standard bands have reduced thickness for weight reduction.



Band Type and Width	Hand Tool	Pneumatic Tool
Standard: .24 (6.1)	601-100	601-106
Slim Standard: .24 (6.1)	601-109	601-110

PART NUMBER	
Sample PN →	<b>527-476</b> XM S T K G
Base P/N	<b>527-476</b>
Finish	<b>XM</b> Electroless Nickel <b>XW</b> Olive Drab Cadmium
Connector Code	<b>Omit</b> All AS81659 Connectors except for Connector Code P1. Backshell Replaces Insert Retainer Plates. <b>P1</b> DPX**E and Class E Environmental Connectors with Interfacial and Grommet Seal. Backshell Installs on Insert Retainer Plates.
Slot Option	<b>Omit</b> None <b>S</b> Slots Included
Qwik-Ty Option	<b>Omit</b> None <b>T</b> Qwik-Ty Strain Relief Arm Included
Band Option	<b>Omit</b> No Band <b>K</b> Standard Band Included <b>J</b> Slim Standard Band Included
Polysulfide Option	<b>Omit</b> None <b>P</b> Polysulfide Stripes (Finish Code XW Only, fig. 1)
EMI Gasket	<b>Omit</b> None <b>G</b> EMI Gasket Included

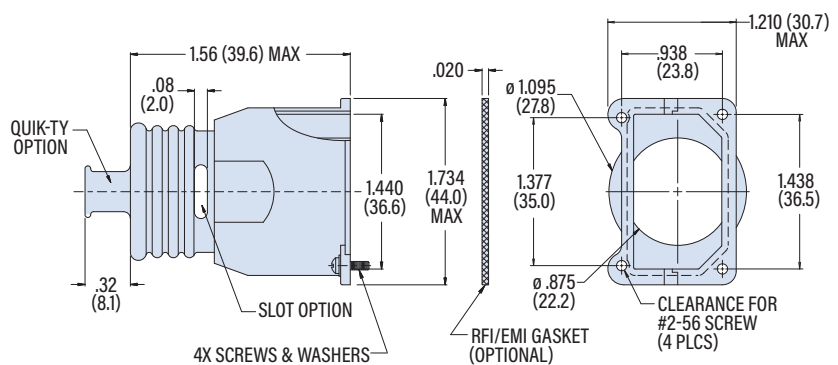

DPX / AS81659 BACKSHELLS