

ENVIRONMENTAL CONNECTORS MIL-DTL-38999 Series I Type



947-101 Flange mount environmental bulkhead feed-thru • 1.00ⁱⁿ Panel

BULKHEAD FEED-THRU

HOW TO ORDER					
Sample Part Number	947-101	-21	-35	B	P
Basic Part Number	947-101 Environmental Bulkhead Feed-Thru				
Shell Sizes	-09, -11, -13, -15, -17, -19, -21, -23, -25				
Insert Arrangement	Per MIL-DTL-38999 Series I MIL-STD-1560				
Alternate Key Position	A, B, C, D, N = Normal				
Contact Termination	P = Pin on Flange Side P1 = Pin to pin		S = Socket on Flange Side S1 = Socket to Socket		

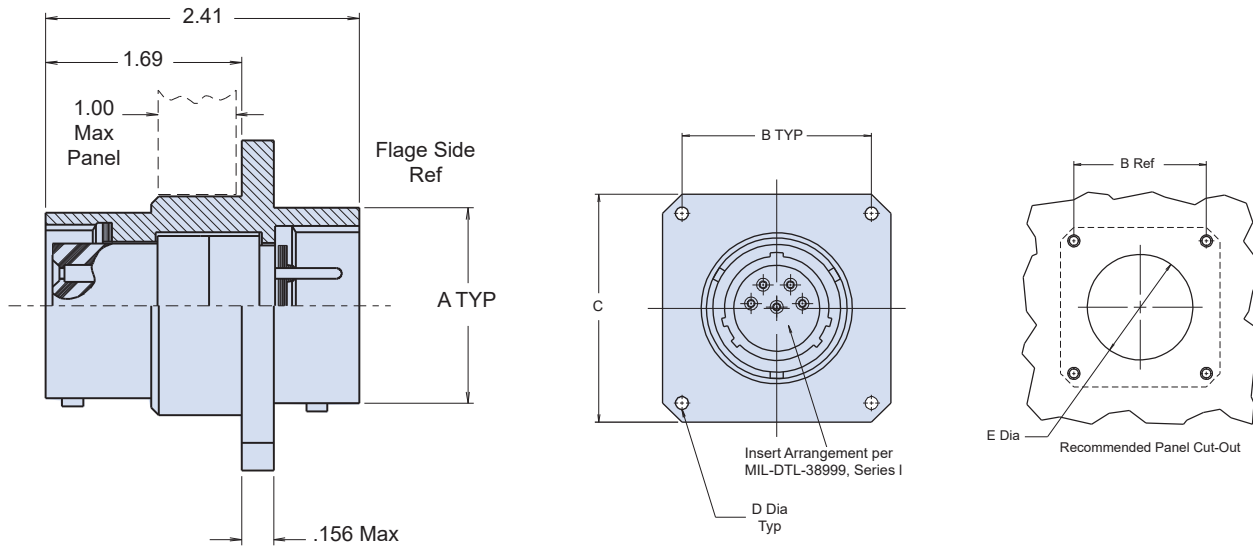

NOTES

- Material/finish:
Shells and nuts—Al alloy, 6061-T6, QQ-A-225/8/cadmium O.D. per QQ-P-416 Type II, Class 3 over electroless nickel, Mil-C-26074, Class 1/2/3/4, Grade A/B/C, 500 hr. salt spray
Contacts—lead nickel copper/gold plate, MIL-G-45204, Type II, Class I
Bayonet pins—AISI 300 series stainless steel/passivate, QQ-P-35
Hoods—AISI 305 series stainless steel/passivate, QQ-P-35.
Inserts—Epiall 1908
Seals—silicone per ZZ-R-765

TABLE I: CONNECTOR DIMENSIONS

SHELL SIZE	A MAX	B SQ	C SQ	D DIA	E ±.005(0.1)
09	.573(14.6)	.719(18.3)	.938(23.8)	.125(3.2)	.703(17.9)
11	.701(17.8)	.812(20.6)	1.031(26.2)	.125(3.2)	.827(21.0)
13	.851(21.6)	.906(23.0)	1.125(28.8)	.125(3.2)	1.015(25.8)
15	.976(24.8)	.969(24.6)	1.219(31.0)	.125(3.2)	1.140(29.0)
17	1.101(28.0)	1.062(27.0)	1.312(33.3)	.125(3.2)	1.265(32.1)
19	1.208(30.7)	1.156(29.4)	1.438(36.5)	.125(3.2)	1.390(35.3)
21	1.333(33.9)	1.250(31.8)	1.562(39.7)	.125(3.2)	1.515(38.5)
23	1.458(37.0)	1.375(34.9)	1.688(42.9)	.156(4.0)	1.640(41.7)
25	1.583(40.2)	1.500(38.1)	1.812(46.0)	.156(4.0)	1.765(44.8)