



SERIES 800 UN THREAD MATING Mighty Mouse Connectors and Cables

Receptacles with PC Tails or Solder Cups



Environmental, PCB Receptacle 800-012 connectors feature low profile shells for minimum protrusion inside enclosures and integral board standoffs. Contacts are non-removable. Specify 800-012 connectors for applications where open face water immersion is not a requirement.

Water Tight PCB Receptacle 800-040 connectors are identical to 800-012, but are specially sealed ("MOD-518") and 100% tested to maintain a helium leak rate of less than 1×10^{-4} cc/second at one ATM. Connectors meet MIL-STD-810 Method 512G immersion requirements in unmated/open face condition.

How To Order						
Sample Part Number	800-012	-07	M	7-10	P	Z
Series	800-012 = Environmental Receptacle with Solder Cups or PC Tails 800-040 = Receptacle, same as 800-012,					
Shell Style (See Table I)	-02 = Square Flange -07 = Jam-Nut (See Jam-Nut Panel Cutout Dimensions Page D)					
Shell Material and Finish	C = Aluminum / Black Anodize (Non-Conductive) M = Aluminum / Electroless Nickel NF = Aluminum / Cadmium with Olive Drab Chromate ZNU = Aluminum / Zinc-Nickel with Black Chromate MT = Aluminum / Nickel-PTFE Z1 = Stainless Steel / Passivated					
Shell Size - Insert Arrangement	See Contact Arrangements page D-4					
Contact Type	P = Pin, PC Tail S = Socket, PC Tail		E = Pin, Solder Cup F = Socket, Solder Cup			
Polarization (See Table II)	N = Normal X = Pos. X Y = Pos. Y Z = Pos. Z					

Table II: Shell Key Positions ^{1,2}	
Shell Size 5 and 6	Shell Size 7 thru 12
Key Position	Key Rotation
N Normal	150°
X	140°
Y	130°
Z	120°

Shell sizes 5 thru 6 and insert arrangement 8-13: master key is located at top dead center for normal (N) position. Shell size 7 thru 12: master key is rotated 90° from TDC for normal position

Table I: Shell Style	
-02 Square Flange Front Mount	-07 Jam-Nut for Rear Panel Mounting

NOTE

- Shell sizes 5 thru 6 and insert arrangement 8-13: master key is located at top dead center (TDC) for normal (N) position.
- Shell size 7 thru 12: master key is rotated 90° from TDC for normal position
- See page D-7 for panel cut-out dimensions
- Material / finish:
 - Receptacle shell: aluminum alloy or CRES / see How to Order Table
 - Insulator: High Grade Rigid Dielectric / N.A.
 - Interfacial seal, O-ring: fluorosilicone rubber
 - Contact: copper alloy / gold plate per ASTM B 488, Type II, Class 1.25, over a suitable underplate
 - Potting compound: epoxy

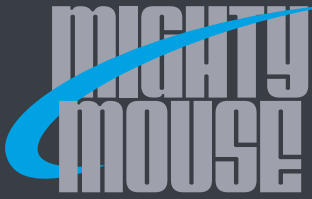

SERIES 800 UN THREAD MATING
Mighty Mouse Connectors and Cables
 Square Flange-Mount Receptacle
 with PC Tails or Solder Cups



SQUARE FLANGE-MOUNT PCB RECEPTACLE - SHELL STYLE 02

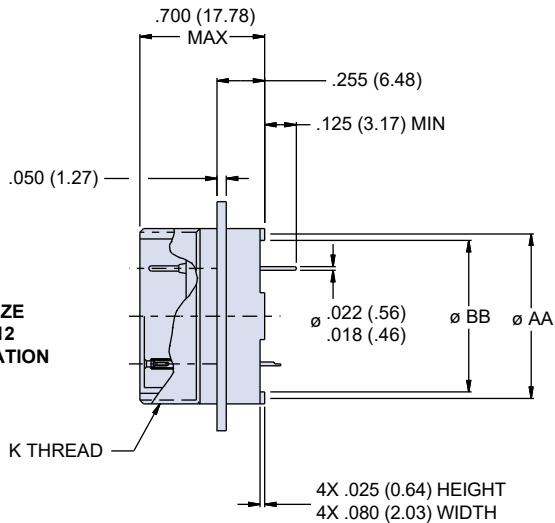
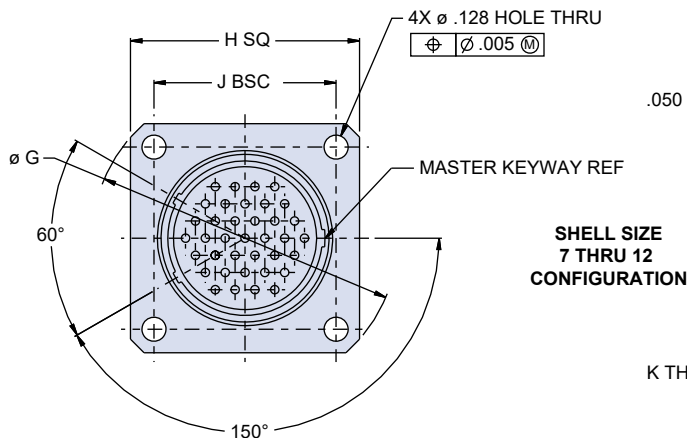
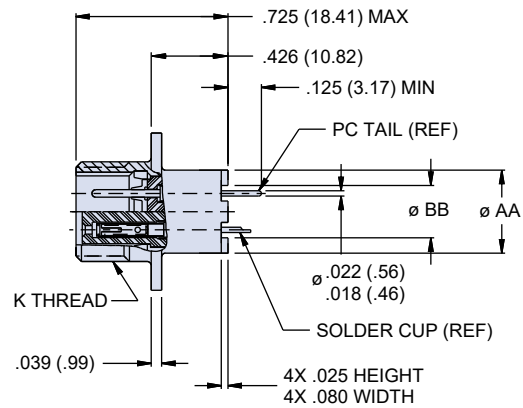
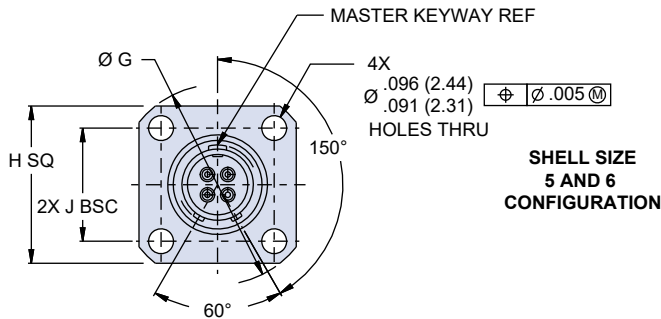

Dimensions						
Shell Size	Ø G	H SQ	J BSC	K Thread	Ø AA O.D.	Ø BB I.D.
5	.680 (17.27)	.527 (13.39)	.363 (9.22)	.3125-28 UN-2A	.265 (6.73)	.186 (4.72)
6	.750 (19.05)	.588 (14.94)	.423 (10.74)	.3750-28 UN-2A	.330 (8.38)	.238 (6.05)
7	.850 (21.59)	.650 (16.51)	.483 (12.27)	.4375-28 UNEF-2A	.424 (10.77)	.327 (8.31)
8	.938 (23.83)	.710 (18.03)	.542 (13.77)	.5000-32 UN-2A	.448 (11.38)	.388 (9.86)
9	1.250 (31.75)	.938 (23.83)	.719 (18.26)	.5625-32 UN-2A	.500 (12.70)	.446 (11.33)
10	1.250 (31.75)	.938 (23.83)	.719 (18.26)	.6250-32 UN-2A	.575 (14.60)	.515 (13.08)
12	1.375 (34.92)	1.031 (26.19)	.812 (20.62)	.7500-28 UN-2A	.660 (16.76)	.599 (15.21)

SERIES 800 UN THREAD MATING

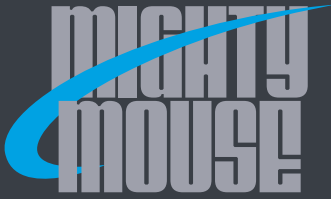

SERIES 800 UN THREAD MATING

Mighty Mouse Connectors and Cables



Jam-Nut Receptacle with PC Tails or Solder Cups

JAM-NUT MOUNT PCB RECEPTACLE - SHELL STYLE 07

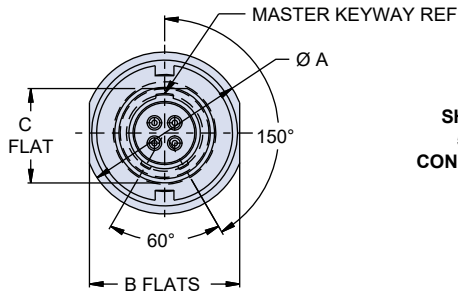

**SHELL SIZE
5 AND 6
CONFIGURATION**

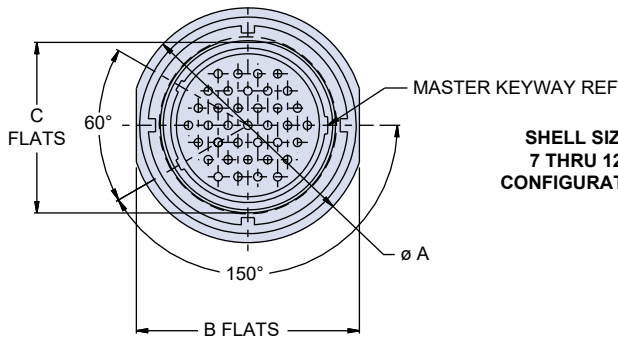
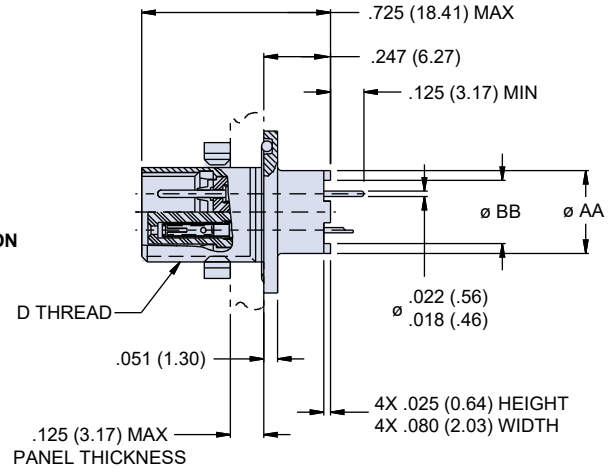

**SHELL SIZE
7 THRU 12
CONFIGURATION**

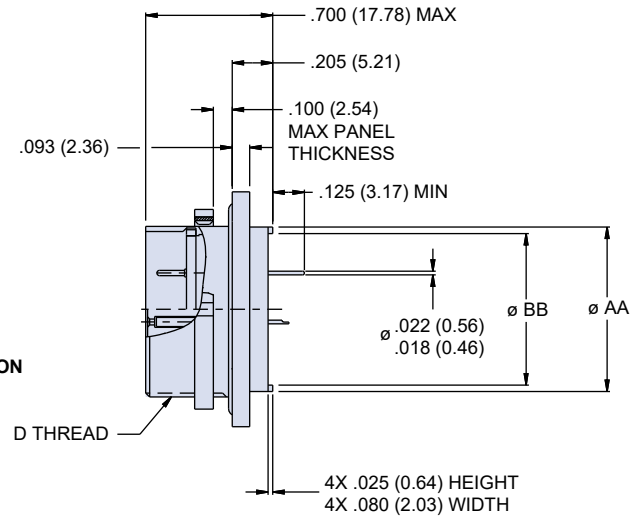

Dimensions

Shell Size	Ø A	B Flat	C Flat	D Thread
5	.541 (13.74)	.500 (12.70)	.285 (7.24)	.3125-28 UN-2A
6	.610 (15.49)	.562 (14.27)	.352 (8.94)	.3750-28 UN-2A
7	.670 (17.02)	.635 (16.13)	.411 (10.44)	.4375-28 UNEF-2A
8	.775 (19.68)	.735 (18.67)	.473 (12.01)	.5000-32 UN-2A
9	.875 (22.23)	.806 (20.47)	.530 (13.46)	.5625-32 UN-2A
10	.980 (24.89)	.940 (23.88)	.604 (15.34)	.6250-32 UN-2A
12	1.062 (26.97)	.986 (25.04)	.712 (18.08)	.7500-28 UN-2A

SERIES 800 UN THREAD MATING