

# HEAT SHRINK TERMINATION SLEEVES

## AS83519/2 Type HST Sleeve



### GS83519/2 • With Pre-Installed Lead Wire



Designed to meet SAE AS83519 performance requirements, Glenair Heat Shrink Termination (HST) shield to ground termination sleeves with pre-installed lead wire are fabricated from radiation cross-linked translucent blue PVDF tubing. Each HST device is equipped with a pre-fluxed solder preform and thermally-stabilized thermoplastic sealing rings that encapsulate and protect the shield-to-ground termination.

#### MATERIAL AND PERFORMANCE NOTES

- Insulation sleeve: heat-shrinkable, translucent blue PVDF
- Radiation crosslinked per AS23053/8
- Solder: Sn63 per IPC-J-STD-006
- Flux: ROL1 per IPC-J-STD-004
- Sealing ring: thermally stabilized thermoplastic, color blue
- Temperature rating: -55°C to +150°C
- Cable jacket rating: 125°C min
- Shield plating: tin or silver

HOW TO ORDER			
Sample Part Number	GS83519	/2	3
Product Series	HST Sleeve		
Basic No.	/2 With pre-installed lead wire		
Size	0 – 20 (See Table)		

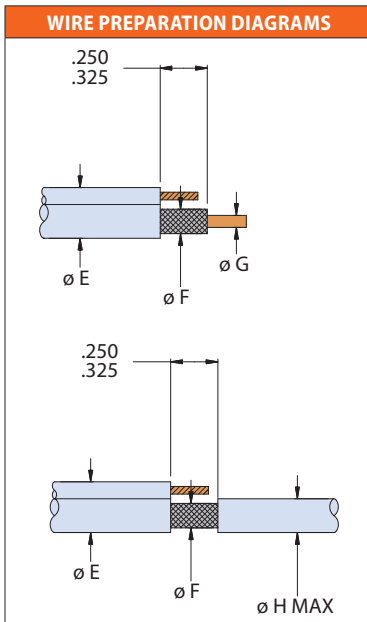
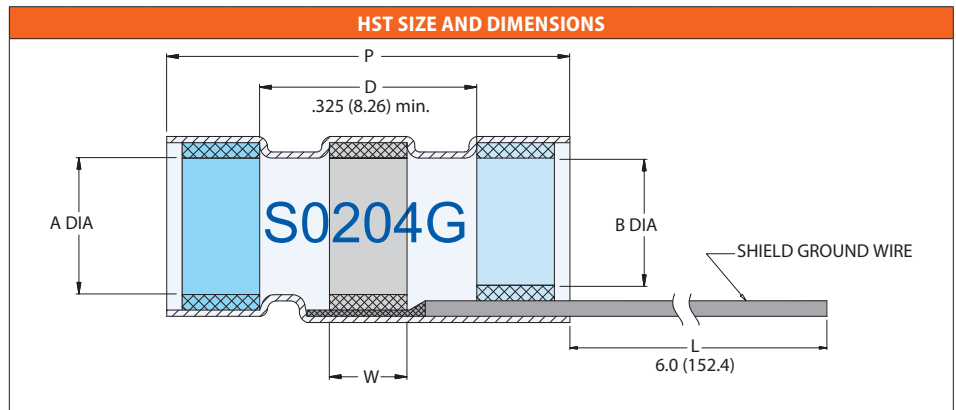

Size	ØA Min	ØB Min	P±.07	W Ref	Lead Wire GS22759-32	Marking Code	ØE Max	ØF Min	ØG Min	ØH Max	M83519/2 P/N Ref.
1	.105 (2.67)	.075 (1.91)	.65 (16.5)	.095 (2.42)	-20-90	S0201G	.105 (2.65)	.035 (0.90)	.020 (0.50)	.075 (1.90)	-1
2	.145 (3.68)	.105 (2.67)	.65 (16.5)	.095 (2.42)	-20-90	S0202G	.145 (3.68)	.055 (1.40)	.030 (0.72)	.105 (2.65)	-2
3	.200 (5.08)	.170 (4.32)	.65 (16.5)	.125 (3.18)	-20-90	S0203G	.200 (5.08)	.085 (2.15)	.050 (1.25)	.170 (4.30)	-3
4	.255 (6.48)	.235 (5.97)	.75 (19.0)	.125 (3.18)	-20-90	S0204G	.255 (6.45)	.130 (3.30)	.070 (1.80)	.235 (5.95)	-4
5	.300 (7.62)	.275 (7.0)	.75 (19.0)	.125 (3.18)	-20-90	S0205G	.300 (7.60)	.170 (4.30)	.100 (2.50)	.275 (7.00)	-5
6	.105 (2.67)	.075 (1.91)	.65 (16.5)	.095 (2.42)	-22-90	S0206G	.105 (2.65)	.035 (0.90)	.020 (0.50)	.075 (1.90)	-6
7	.145 (3.68)	.105 (2.67)	.65 (16.5)	.095 (2.42)	-22-90	S0207G	.145 (3.68)	.055 (1.40)	.030 (0.72)	.105 (2.65)	-7
8	.200 (5.08)	.170 (4.32)	.65 (16.5)	.125 (3.18)	-22-90	S0208G	.200 (5.08)	.085 (2.15)	.050 (1.25)	.170 (4.30)	-8
9	.255 (6.48)	.235 (5.97)	.75 (19.0)	.125 (3.18)	-22-90	S0209G	.255 (6.45)	.130 (3.30)	.070 (1.80)	.235 (5.95)	-9
10	.300 (7.62)	.275 (7.0)	.75 (19.0)	.125 (3.18)	-22-90	S0210G	.300 (7.60)	.170 (4.30)	.100 (2.50)	.275 (7.00)	-10
11	.105 (2.67)	.075 (1.91)	.65 (16.5)	.095 (2.42)	-24-90	S0211G	.105 (2.65)	.035 (0.90)	.020 (0.50)	.075 (1.90)	-11
12	.145 (3.68)	.105 (2.67)	.65 (16.5)	.095 (2.42)	-24-90	S0212G	.145 (3.68)	.055 (1.40)	.030 (0.72)	.105 (2.65)	-12
13	.200 (5.08)	.170 (4.32)	.65 (16.5)	.125 (3.18)	-24-90	S0213G	.200 (5.08)	.085 (2.15)	.050 (1.25)	.170 (4.30)	-13
14	.255 (6.48)	.235 (5.97)	.75 (19.0)	.125 (3.18)	-24-90	S0214G	.255 (6.45)	.130 (3.30)	.070 (1.80)	.235 (5.95)	-14
15	.300 (7.62)	.275 (7.0)	.75 (19.0)	.125 (3.18)	-24-90	S0215G	.300 (7.60)	.170 (4.30)	.100 (2.50)	.275 (7.00)	-15
16	.105 (2.67)	.075 (1.91)	.65 (16.5)	.095 (2.42)	-26-90	S0216G	.105 (2.65)	.035 (0.90)	.020 (0.50)	.075 (1.90)	-16
17	.145 (3.68)	.105 (2.67)	.65 (16.5)	.095 (2.42)	-26-90	S0217G	.145 (3.68)	.055 (1.40)	.030 (0.72)	.105 (2.65)	-17
18	.200 (5.08)	.170 (4.32)	.65 (16.5)	.125 (3.18)	-26-90	S0218G	.200 (5.08)	.085 (2.15)	.050 (1.25)	.170 (4.30)	-18
19	.255 (6.48)	.235 (5.97)	.75 (19.0)	.125 (3.18)	-26-90	S0219G	.255 (6.45)	.130 (3.30)	.070 (1.80)	.235 (5.95)	-19
20	.300 (7.62)	.275 (7.0)	.75 (19.0)	.125 (3.18)	-26-90	S0220G	.300 (7.60)	.170 (4.30)	.100 (2.50)	.275 (7.00)	-20