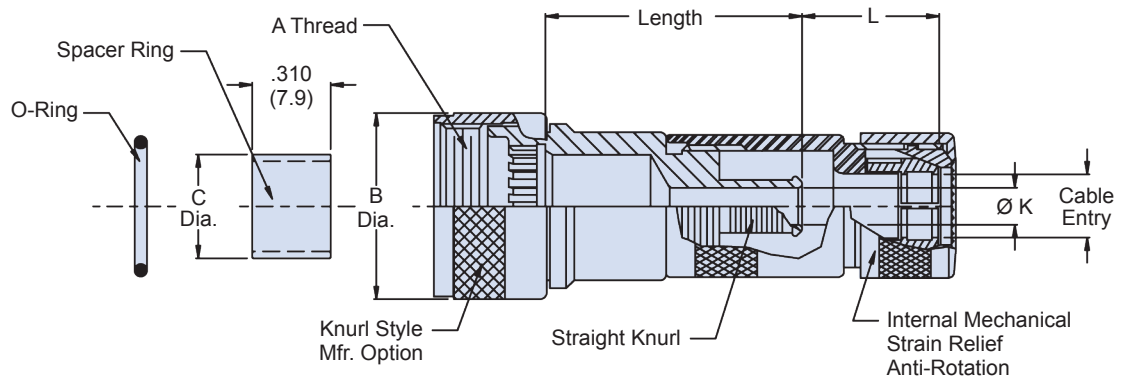
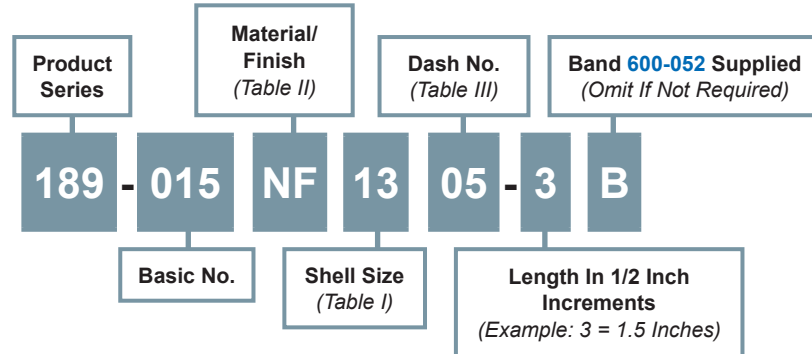

MIL-PRF-28876 and 189-015 banding backshell
How To Order

Material and Plating

Adapter, Coupling Nut, Spacer Ring see Table II
 Clamp Components: Ryton R 4XT-Black, Ultem 1000-Natural
 Anti-Rotation Device: Torlon 42031-Natural
 O-Ring: Fluorosilicone

Notes

Glenair 600 Series Backshell assembly tools are recommended for assembly and installation. Standard minimum length: 1.5 inches, for shorter length consult factory.
 Spacer Ring and O-Ring are packaged loose and must be installed with Connector at time of assembly. The spacer is utilized to retain the terminus Insert.
 For Shield termination see Glenair drawing 600-050 & 600-052.
 Consult factory for larger cable size.
 MIL-I-32053/4 & /5 Shrink sleeve to be packaged loose in a plastic bag.
 MIL-I-32053/4 Shrink Sleeving to be heat shrink over rear of Adapter before
 MIL-I-32053/5 Shrink Sleeving.
 For assembly instructions, see GAP-064

189-015

Environmental Banding Backshell
for Multichannel M85045 Shipboard Fiber Optic Cable
for Use with MIL-PRF-28876 or Glenair 180-040 Connectors



MIL-PRF-28876
Connectors

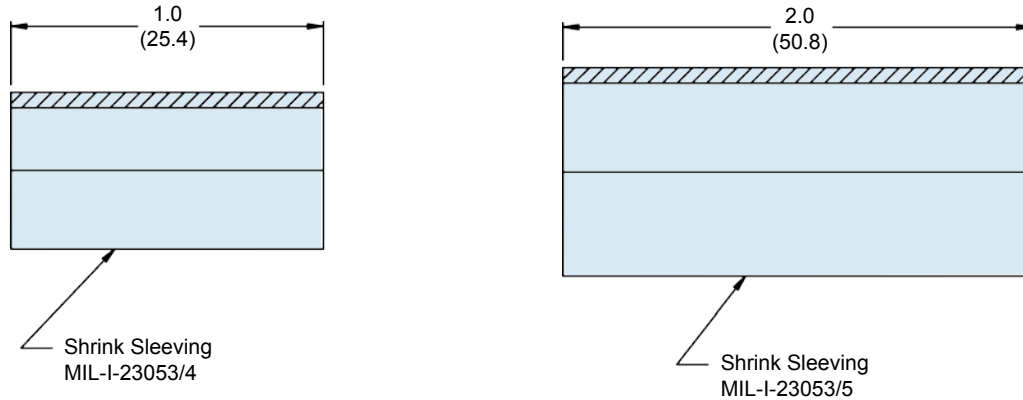

Shell Size	Designator (Ref)	A Thread Class 2B	B Max	C Max	Max Dash Number
11	A	3/4 -20 UNEF	1.028 (26.1)	.410 (10.4)	05
13	B	7/8 -20 UNEF	1.141 (29.0)	.532 (13.5)	05
15	C	1 -20 UNEF	1.263 (32.1)	.710 (18.0)	07
23	F	1-7/16 -18 UNEF	1.703 (43.3)	1.116 (28.3)	13

Code	Material	Finish Description
M	Aluminum Alloy	Electroless Nickel
NF		Cadmium/Olive Drab Over Electroless Nickel (500 hour salt spray)

Refer to Appendix for material/finish details

Dash No.	Clamp Size	Cable Dia Max	K Dia ±.005 (0.1)	L Max	MIL-I-23053 Shrink Sleeve	MIL-I-23053 Shrink Sleeve	Cable Entry Dia	
							Minimum	Maximum
05	12	.280 (7.1)	.312 (7.9)	1.11 (28.2)	/4-203-0	/5-107-0	.233 (5.2)	.375 (9.5)
07	16	.395 (10.0)	.438 (11.1)	1.21 (30.7)	/4-204-0	/5-108-0	.358 (8.3)	.500 (12.7)
09	20	.510 (13.0)	.562 (14.3)	1.21 (30.7)	/4-204-0	/5-109-0	.482 (11.5)	.625 (15.9)
11	24	.621 (15.8)	.688 (17.5)	1.21 (30.7)	/4-205-0	/5-106-0	.545 (13.1)	.750 (19.1)
13	28	.736 (18.7)	.812 (20.6)	1.36 (34.5)	/4-205-0	/5-110-0	.670 (16.3)	.875 (22.2)

