

SeaKing™ Fiber Optic  
10K PSI open-face  
pressure rated fiber  
optic connectors,  
cables and jumpers

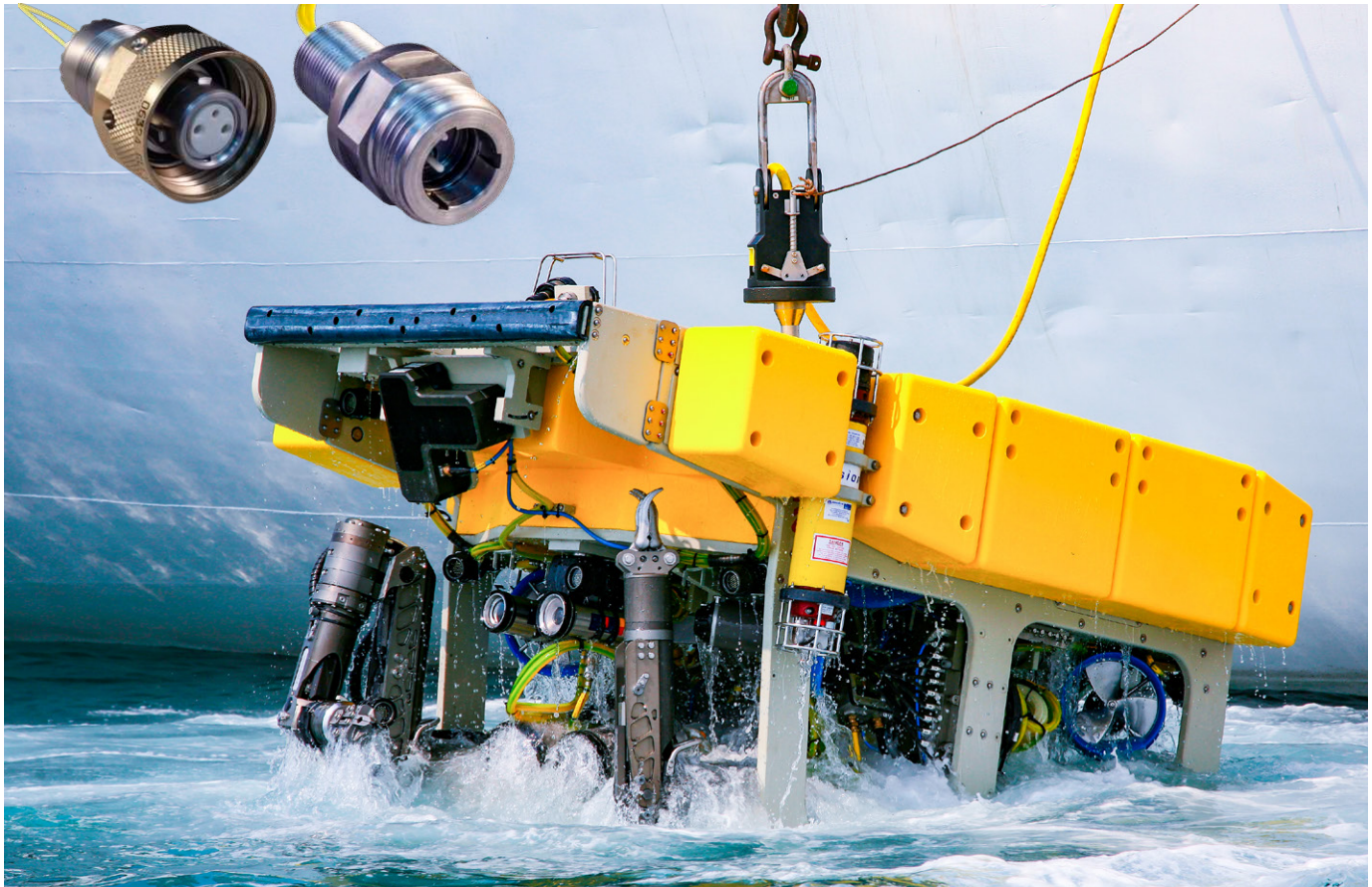

Data-intensive applications such as towed array sonar systems, well logging and monitoring equipment, digital seismic streamers, as well as magnetic flux leakage and ultrasonic inspection sensors used in intelligent pipeline inspection are ideally suited for ruggedized high-pressure fiber optics. Fiber optic interconnect systems deliver ultra high data bandwidth, immunity from RFI and other forms of electromagnetic interference, as well as reduced size and weight compared to high-speed copper.

- Overmolded and PBOF butt-joint assemblies
- Full hydrostatic qualification test report available
- Wide range of fiber and hybrid fiber/electric layouts
- Singlemode and multimode
- <1.0db per mated connection data loss for singlemode

## SeaKing Fiber Optic Series Overview

### ENVIRONMENTAL OVERMOLDED FIBER OPTIC JUMPERS

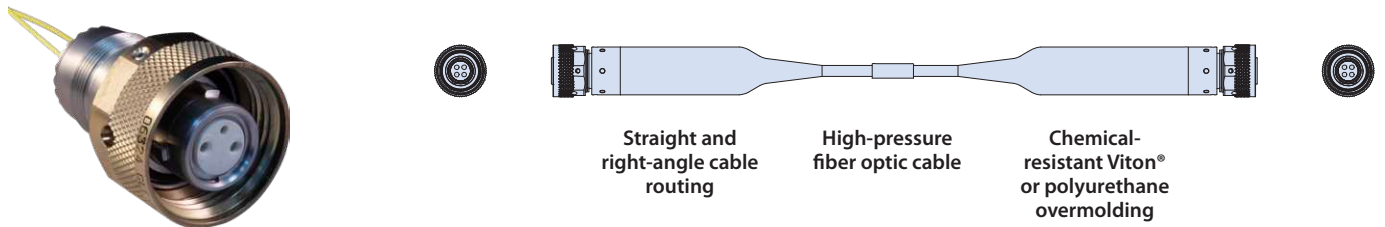

### PRESSURE-BALANCED OIL-FILLED (PBOF) HIGH-PRESSURE FIBER OPTIC ASSEMBLIES

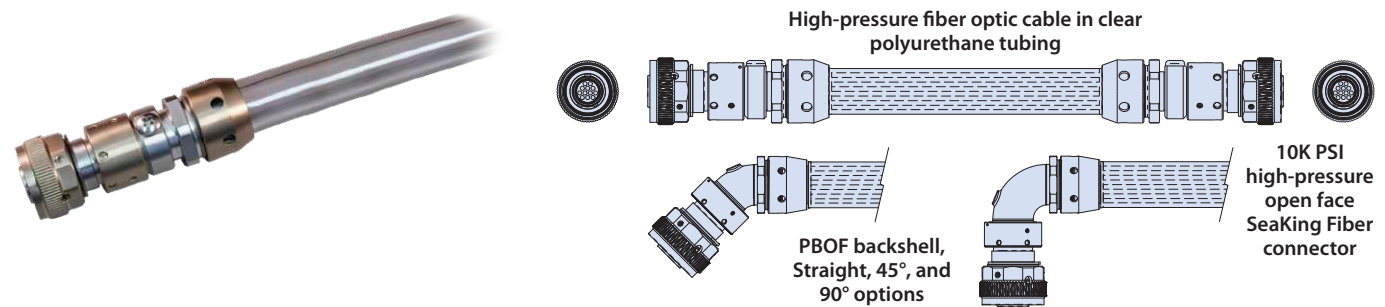

### SEAKING™ BCR OR FCR TO COMMERCIAL FIBER OPTIC PIGTAIL ASSEMBLY FOR I/O-TO-BOARD MODULE APPLICATIONS

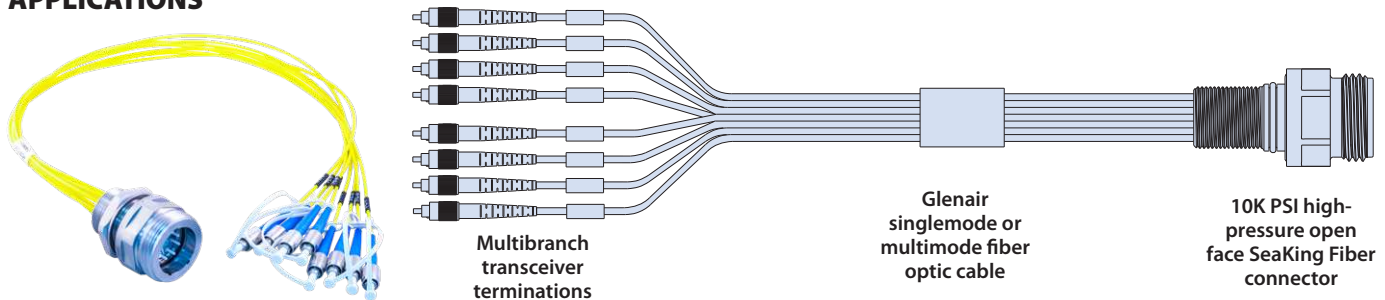

### KEY AND KEYWAY POSITIONS

Alternate Keyway Positions		
Key Position	Key Rotation	
	A°	B°
Normal (N)	150°	210°
A	75°	210°
B	95°	230°
C	140°	275°

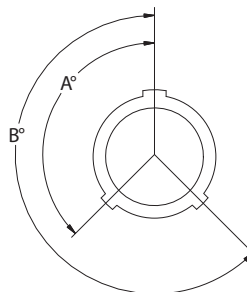

Plug (Key)

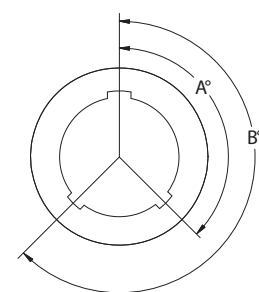

Receptacle (Keyway)