

189-014 PEEK Convoluted Tubing Adapter for MIL-PRF-28876 fiber optic connectors

NAVSEA / Underwater Fiber Optics



HOW TO ORDER			
Sample Part Number	189-014	NF	11
Basic Number	Adapter Backshell for PEEK Convoluted Tubing		
Material/Finish	See Material and Finish table		
Shell Size	See Shell Size / Dimensions / Peek Conduit Size table		

MATERIAL AND FINISH

- Spacer Ring: Monel

NOTES

- Spacer Ring is packaged loose and must be installed with Connector at time of assembly to retain Terminus Insert.
- For 45° or 90° Backshell option, see Glenair drawing 189-021.

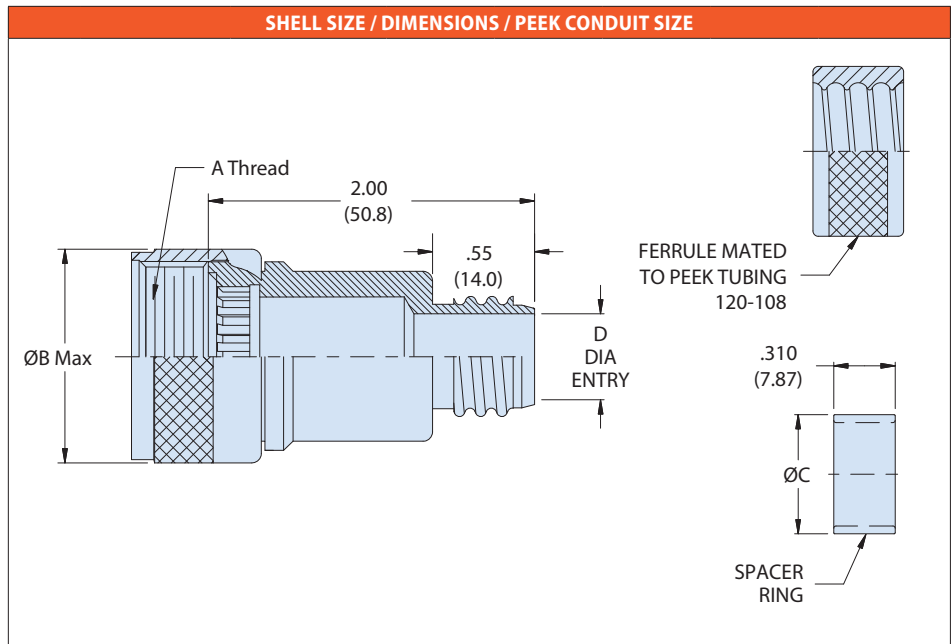

Shell Size	Designator (Ref)	A Thread Class 2B	ØB Max	ØC Max	Ø D Entry	PEEK Conduit Size	
						Frac. Size	Dash No.
11	A	3/4-20 UNEF	.960 (24.4)	.410 (10.4)	.390 (9.91)	1/2	16
13	B	7/8-20 UNEF	1.09 (27.7)	.532 (13.5)	.390 (9.91)	1/2	16
15	C	1-20 UNEF	1.26 (32.0)	.710 (18.0)	.390 (9.91)	1/2	16
23	F	1 7/16-18 UNEF	1.70 (43.2)	1.12 (28.4)	.890 (22.6)	1	32

MATERIAL AND FINISH		
Code	Material	Finish Description
GB4	Aluminum Alloy	Hard Anodize, Black with PTFE
J		Gold Iridite over Cad Plate over Nickel
ME		Electroless Nickel
MT		Nickel-PTFE, Grey
NF		Cadmium, Olive Drab
T		Cad Plate / Bright Dip over Nickel
TZ		Tin-Zinc, Bronze-Gold
ZR		Zinc-Nickel, Black