



SERIES 77 Lipless Boots



770-005A Right Angle Boot How to Order



Lipless, 90° shrink boots provide mechanical and environmental protection from damage and debris. Boots are available in eight material options with five adhesive choices. Glenair 90° boots are made in accordance with AS85049 and fit most circular connectors. All adhesive lined and unlined shrink boots are RoHS compliant. Shrink boots are water-tight when equipped with factory installed or user-installed adhesive. Lipless boots bind to accessory threads at rear of connector without an additional adapter resulting in a lower profile and can be ordered with potting holes to fit your requirements. Choose boot size based on rear connector thread diameter and cable diameter.

D

How to Order							
Sample Part Number	770	-005	A	1	03	W1	-PP
Product Series	770 = Series 77 shrink boot						
Basic Number	005 = lipless boot without eyelet						
Angular Function	A = 90°						
Material	See material and adhesives table						
Boot Size	00, 02, 03, 04, 05, 06, 07, 08; see shell size cross reference in dimensions table						
Adhesive Lined	Omit for none; see material and adhesives table						
Potting Ports	PP = potting port Omit for none						

Material and Adhesive Compatibility						
Material Code	Material Description (Compound No.)	Hot Melt Adhesives			High Performance Epoxy Adhesives	
		W1	W2	W3 (TACOM approved)	R	U
		High Temperature -55°C to 125°C	Standard -55°C to 70°C	Elastomeric -55°C to 125°C	Pre-Coat -75°C to 150°C	Two-Part -75°C to 155°C
1	High-Performance Semi-Rigid Elastomer (2025)	●	●		●	Type U epoxy adhesive is compatible with all boot materials. Ordered separately, user-installed (779-001). Order boot with no adhesive lining.
2	Zero Halogen Semi-Rigid Polyolefin (2010)	●	●		●	
3	General Purpose Flexible Polyolefin (2040)		●			
5	Viton Fluoroelastomer Blend (2050)	●		●	●	
6	High Performance Elastomer Alloy (2051)	●		●		
7	Semi-Rigid Polyolefin (2071)	●	●			
8	Low Outgassing Fluoropolymer Alloy (2008)	Material Type 8 not available with pre-coat adhesive. Use Type U two-part epoxy				
9	Low Temp Flexible Polyolefin (2013)		●			

NOTES

1. See **Modification Codes** listed in Section A for material color options available for **Type 1 (compound 2025)** material.
2. See **Reference Information** pages in this section for material and adhesive selection guides.
3. Recovered dimension apply to unrestricted recovery. Dimensions may differ than shown when boots are installed over assembly.



SERIES 77 Lipless Boots



770-005A Right Angle Boot Dimensions

Lipless Straight Shrink Boots: Dimensions

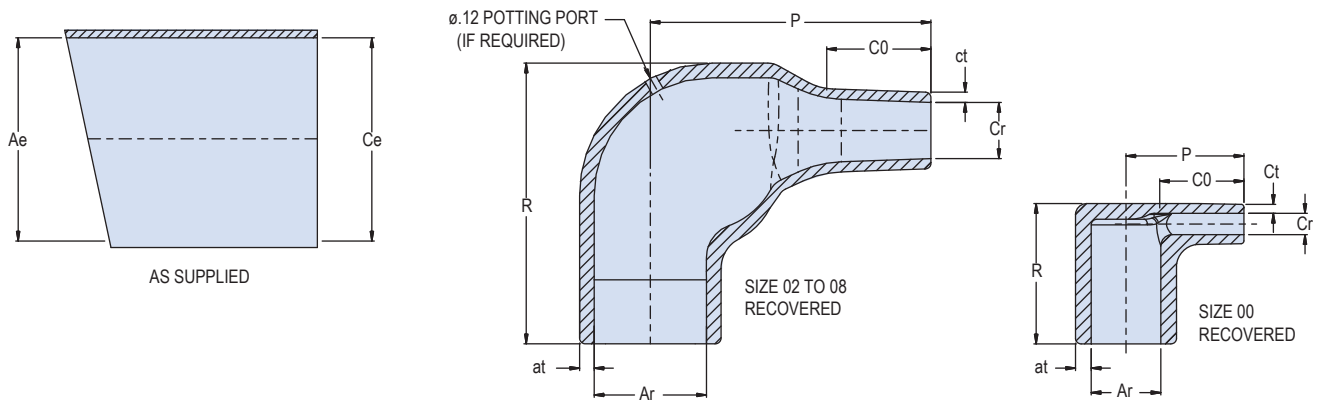

Dimensions											
Boot Size	Glenair US Part Marking	Shell Size	Ae Dia Min	Ce Dia Min	Ar Dia Max	at ±30%	Cr Dia Max	ct ±20%	CO Ref	P ±20%	R Ref
00	A00	5	.354 (9.0)	.354 (9.0)	.236 (6.0)	.039 (1.0)	.079 (2.0)	.028 (0.7)	.236 (6.0)	.413 (10.5)	.492 (12.5)
02	A02	7	.669 (17.0)	.669 (17.0)	.315 (8.0)	.051 (1.3)	.138 (3.5)	.028 (0.7)	.276 (7.0)	.787 (20.0)	.787 (20.0)
03	A03	9	.945 (24.0)	.945 (24.0)	.394 (10.0)	.063 (1.6)	.197 (5.0)	.035 (0.9)	.394 (10.0)	.984 (25.0)	.984 (25.0)
04	A04	11-15	1.181 (30.0)	1.181 (30.0)	.532 (13.5)	.071 (1.8)	.217 (5.5)	.039 (1.0)	.472 (12.0)	1.260 (32.0)	1.063 (27.0)
05	A05	13-17	1.260 (32.0)	1.260 (32.0)	.709 (18.0)	.071 (1.8)	.276 (7.0)	.047 (1.2)	.591 (15.0)	1.535 (39.0)	1.260 (32.0)
06	A06	17-21	1.417 (36.0)	1.417 (36.0)	.886 (22.5)	.079 (2.0)	.335 (8.5)	.047 (1.2)	.630 (16.0)	1.929 (49.0)	1.496 (38.0)
07	A07	21-23	1.693 (43.0)	1.693 (43.0)	1.102 (28.0)	.087 (2.2)	.394 (10.0)	.059 (1.5)	.709 (18.0)	2.165 (55.0)	1.850 (47.0)
08	A08	23-25	2.165 (55.0)	2.165 (55.0)	1.378 (35.0)	.130 (3.3)	.591 (15.0)	.079 (2.0)	1.260 (32.0)	3.150 (80.0)	2.165 (55.0)

For materials Type 2, Type 3 and Type 9, dimension 'Ce' is nominal

Lipless Straight Boots: Part Marking, Raised Lettering

