

SERIES 79 MICRO-CRIMP RECTANGULAR CONNECTORS

Backshells and Accessories



799-164

Piggyback EMI Banding Backshell, Series 792

- ◆ for Series 792 connectors
- ◆ Internal grommet fits high speed data cables





EMI, piggyback, split. 799-164 piggyback backshell fits Series 792 connectors with rear groove on shell. Internal fluorosilicone wire strain relief grommet accommodates high speed cables. Available with Qwik-Ty strain relief arm or slots/holes for lacing tape. Terminate cable shield to backshell with BandMaster ATS band strap. Aluminum with stainless steel screws.

799-164

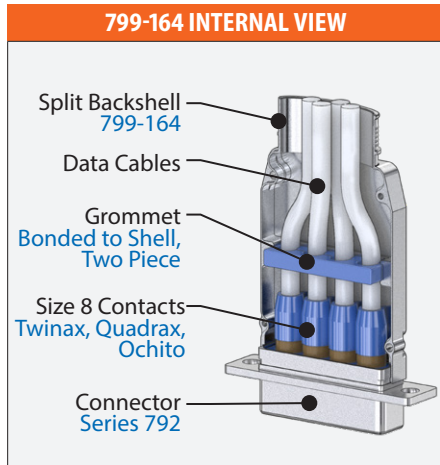
This accessory fits Series 792 cable connectors with #8 insert arrangements.
792-001, 792-002
Not for use with insert arrangements with #23 contacts.

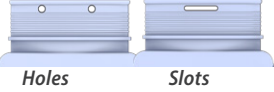

HOW TO ORDER	
Sample Part Number	799-164 M D B T N 2
Basic Part Number	799-164
Finish	<ul style="list-style-type: none"> M Electroless Nickel MT Nickel / PTFE N Olive Drab Cadmium TZ Tin-Zinc ZR Black Zinc-Nickel
Shell Size	A B C D E F
Band	<ul style="list-style-type: none"> B Standard Band Included S Slim Standard Band Included M Micro Band Included J Micro Slim Band Included L Micro-Max Band Included 
Qwik-Ty	<ul style="list-style-type: none"> T Qwik-Ty Strain Relief Arm N No Qwik-Ty 
Lace-Tie Option	<ul style="list-style-type: none"> H Holes for Lace-Tie S Slots for Lace-Tie N No Lace-Tie Provision 
Cable Size	<ul style="list-style-type: none"> 1 .188 (4.8) Max Individual Cable Diameter 2 .250 (6.4) Max Individual Cable Diameter 3 .313 (8.0) Max Individual Cable Diameter

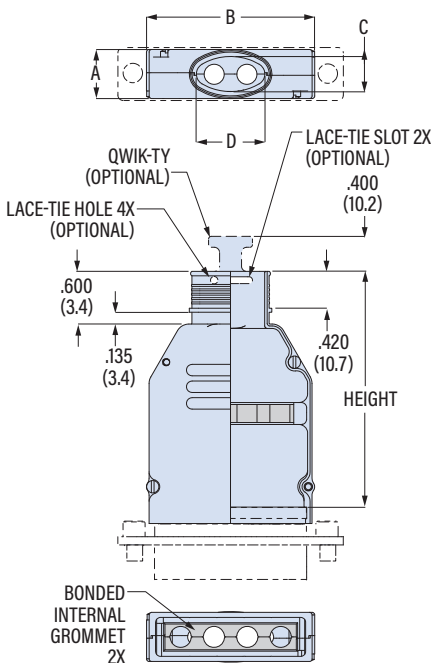

Shell Size	A Max		B Max		Height		Cable Size 1		Cable Size 2		Cable Size 3							
	in	mm	in	mm	in	mm	C	D	C	D	C	D						
A	.575	14.6	.810	20.6	2.380	60.5	.200	5.1	.300	7.6	.260	6.6	.360	9.1	.320	8.1	.420	10.7
B	.575	14.6	1.185	30.1	2.690	68.3	.250	6.4	.390	9.9	.340	8.6	.510	13.0	.380	9.7	.630	16.0
C	.575	14.6	1.560	39.6	2.940	74.7	.400	10.2	.440	11.2	.400	10.2	.740	18.8	.400	10.2	.940	23.9
D	.575	14.6	1.935	49.1	3.120	79.2	.400	10.2	.520	13.2	.400	10.2	.960	24.4	.400	10.2	1.250	31.8
E	.575	14.6	2.310	58.7	3.310	84.1	.400	10.2	.690	17.5	.400	10.2	1.170	29.7	.400	10.2	1.550	39.4
F	.950	24.1	2.310	58.7	3.380	85.9	.700	17.8	.700	17.8	.775	19.7	.775	19.7	.775	19.7	1.650	41.9

BAND OPTIONS				
Band Type	Band Width	Band P/N 14" Length Pre-Coiled	Hand Tool	Pneumatic Tool
Standard	.24 (6.1)	601-041	601-100	601-106
Slim Standard	.24 (6.1)	601-573	601-109	601-110
Micro	.12 (3.0)	601-065	601-101	601-107
Micro Slim	.12 (3.0)	601-603	601-122	601-123
Micro-Max	.12 (3.0)	601-703	601-129	601-130

Stainless steel band strap provides fast, cost-effective and highly reliable termination of braided metallic shielding. *Slim Standard* and *Micro Slim* bands have reduced thickness for weight reduction. High tension *Micro-Max* bands reduce braid-to-shell electrical resistance.

BACKSHELLS AND ACCESSORIES

MICRO-CRIMP RECTANGULAR CONNECTORS

Series 792 High-Speed



Series 792 Insert Arrangements

SERIES 792 INSERT ARRANGEMENTS

Thermoplastic Insert	Grounded All-Aluminum	No. of Contacts	
		#8	#23
A-1W1	A-1G1	1	—
A-3W1		1	2
B-23W1		1	22
B-2W2	B-2G2	2	—
B-6W2		2	4
C-24W2		2	22
C-3W3	3G3	3	—
C-9W3		3	6
D-27W3		3	24
D-4W4	D-4G4	4	—
D-12W4		4	8
E-5W5	E-5G5	5	—
E-15W5		5	10
E-45W3		3	42
F-9W9	F-9G9	9	—
F-31W9		9	22

⚠ Cavity Numbers
Cavity numbers shown are for mating face of plug (socket) connector. Receptacle (pin) numbers are reversed.

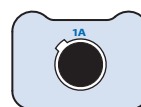

1 #8

A-1W1

A-1G1 Grounded

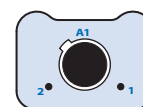

1 #8, 2 #23

A-3W1

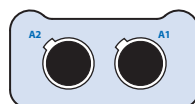

2 #8

B-2W2

B-2G2 Grounded

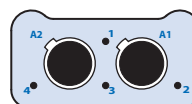

2 #8, 4 #23

B-6W2

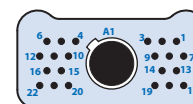

1 #8, 22 #23

B-23W1

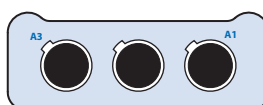

3 #8

C-3W3

C-3G3 Grounded

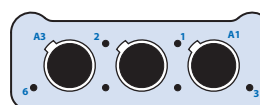

3 #8, 6 #23

C-9W3

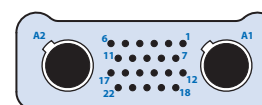

2 #8, 22 #23

C-24W2

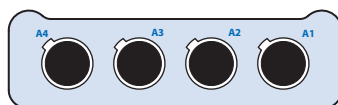

4 #8

D-4W4

D-4G4 Grounded

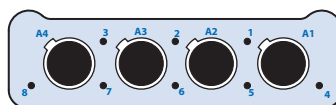

4 #8, 8 #23

D-12W4

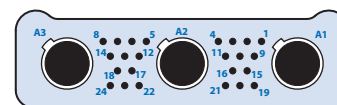

3 #8, 24 #23

D-27W3

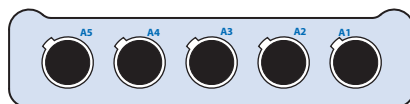

5 #8

E-5W5

E-5G5 Grounded

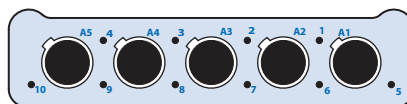

5 #8, 10 #23

E-15W5

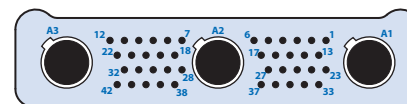

3 #8, 42 #23

E-45W3

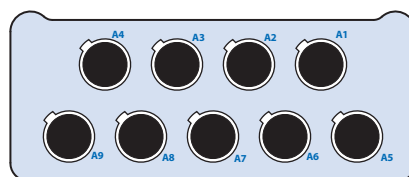

9 #8

F-9W9

F-9G9 Grounded

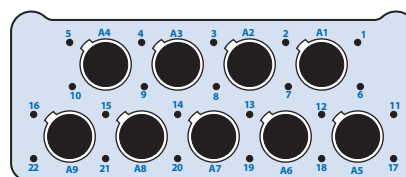

9 #8, 22 #23

F-31W9

Grounded Insert Arrangements

Series 792 connectors are available with thermoplastic inserts ("A-1W1" for example), or with all-aluminum construction for grounding datalink contacts together with the connector shell ("A-1G1").

SERIES 792 HIGH-SPEED

Series 792 Material and Finish Options

SERIES 792 HIGH-SPEED

The Series 792 High-Speed connector is available in five preferred finishes: **electroless nickel, nickel-PTFE, tin-zinc, cadmium, and zinc-nickel.**

Additional material and finish options are available. Replace the preferred plating code with the alternate code from the table below.

TIN-ZINC PLATING

The United States Department of Defense (DOD) has mandated the elimination of cadmium from DOD weapons systems because of toxicity concerns. The European Union has also restricted the use of cadmium on electronics equipment (RoHS). Tin-Zinc is a RoHS cadmium-free sacrificial finish that offers high conductivity and shielding performance, corrosion resistance, solderability, and proven compatibility with legacy cadmium and zinc-nickel finishes. Tin-Zinc is DLA-qualified and RoHS compliant.

SERIES 792 SHELL FINISH OPTIONS

	Electroless Nickel	Nickel-PTFE	Tin-Zinc	Olive Drab Cadmium	Black Zinc-Nickel
Glenair Code	M	MT	TZ	N	ZR
Corrosion Resistance	Fair	Excellent	Excellent	Excellent	Excellent
Salt Spray Hours	48	500	500	500	500
Conductivity	Excellent	Excellent	Very Good	Very Good	Very Good
RoHS Compliant ⁽¹⁾	Yes	Yes	Yes	No	Yes

⁽¹⁾ Does not contain cadmium or hexavalent chromium. Meets EU requirements.

ALTERNATE SHELL MATERIAL AND FINISH CODES

Code	Shell Material	Shell Finish	Finish Specification	Salt Spray Hrs.	Electrical Conductivity	RoHS ⁽¹⁾
C	Alum	Anodize, Black	MIL-PRF-8625	48	Non-Conductive	✓
E⁽²⁾	Alum	Chem Film, Gold	MIL-DTL-5541	168	Conductive	
J	Alum	Cadmium, Yellow	AMS-QQ-P-416	500	Conductive	
Z1	SST	Passivate	AMS2700	500	Conductive	✓
Z2	Alum	Gold	MIL-DTL-45204	48	Conductive	✓
ZM	SST	Electroless Nickel	AMS-C-26074	500	Conductive	✓
ZMT	SST	Nickel-PTFE	AMS2454	1000	Conductive	✓
ZW	SST	Cadmium, Olive Drab	AMS-QQ-P-416	500	Conductive	
ZZR	SST	Zinc-Nickel, Black	ASTM B841	500	Conductive	✓

⁽¹⁾ Does not contain cadmium or hexavalent chromium. Meets EU requirements.

⁽²⁾ Maximum temperature = +125°C

MICRO-CRIMP RECTANGULAR CONNECTORS

Series 792 High-Speed



Specifications

SERIES 792 HIGH-SPEED

CONSTRUCTION

Contacts	Copper alloy, gold over nickel finish
Hood, socket contact	Stainless steel, passivated
Clip, contact retaining	Beryllium copper
Clip, insert retaining	Beryllium copper
Insulators	High performance thermoplastic
Grommet and face seal	Fluorosilicone/silicone blend
Shell	Aluminum
O-ring	Fluorosilicone
EMI spring	Beryllium copper, electroless nickel plated
EMI shroud (90° PCB)	Aluminum
Encapsulant (PCB)	Epoxy
Hardware	Stainless steel, passivated

RATINGS

Voltage (DWV)	Size 23 contacts: 750 VAC Datalink contact outer body to shell: 1800 VAC (ungrounded insert) Quadrax and Ochito inner contact: 500 VAC
Current Rating	Size 23 contacts: 5 amps
Operating Temperature	-65 to +150 °C
Durability	500 mating cycles
Datalink differential Impedance (nom.)	Quadrax: 100 ohms Ochito white, red: 100 ohms Ochito blue: 90 ohms

PRODUCT SPECIFICATIONS

Description	Requirement	Procedure
Contact Resistance	SAE AS39029 Table V	EIA-364-06
Low Level Contact Resistance	SAE AS39029 Table IV	EIA-364-23
Insulation Resistance	5000 megohms minimum	EIA-364-21
Dielectric Withstanding Voltage	#23 contacts 750 volts	EIA-364-20
Current Rating	#23: 5A	EIA-364-70 Method 1
Shell-to-shell Resistance	2.5 millivolt drop maximum (connector with EMI spring)	EIA-364-83
Shielding Effectiveness	100 – 1000MHz: >75 dB, 1 – 4GHz: >60dB, 4 – 10GHz: >40dB	EIA-364-66
Vibration, Sine	20 g	EIA-364-28 Test Condition IV
Vibration, Random	16.91 g rms	EIA-364-28 Test Condition VI Letter J
Mechanical Shock	300 g	EIA-364-27 Condition D
Thermal Shock	-65 to +150 °C	EIA-364-32 Test Condition IV,
Humidity	10 Day, +25 to +65° C	EIA-364-31 Method IV, Step 7b vibration deleted.
Mechanical Durability	500 mating cycles	EIA-364-09
Salt Spray	Plating code M: 48 hours, MT, ZR, N, TZ: 500 hours	EIA-364-26
Solderability, PC Tail Contacts	95% solder coverage. Smooth, bright and even finish.	EIA-364-52 Category 3, 8 hours steam aging
Resistance To Soldering Heat (PCB)	260° C, 10 seconds	EIA-364-56
Fluid Immersion	No damage from immersion in various fuels and oils.	EIA-364-10
Contact Retention	MIL-DTL-38999 Table XVIII	EIA-364-29
Contact Separation Force	SAE AS39029 Table 9	EIA-364-37
Magnetic Permeability	2 μ maximum.	EIA-364-54

MICRO-CRIMP RECTANGULAR CONNECTORS

Series 792 High-Speed



Series 792 Polarization Keying Option

OPTIONAL POLARIZATION KEYS



To prevent mis-mating of identical shell size and insert arrangement connectors

Series 792 connectors are available with an integral polarizing key. Keyed plug connectors have a raised boss on the shell. Receptacles have corresponding keyway. Ordering is simple—just add the keying position letter designator to the end of the part number.

Note: keyed receptacles will mate with unkeyed plugs.

HOW TO ORDER

Step 1	Create a Series 792 connector part number:	792-001SD-4G4MS
Step 2	Add the keying position letter designator A, B, C, D, E, F, G, H, J, or K to the part number.	792-001SD-4G4MS<u>B</u>

MOD-1104 POLARIZING KEY LOCATIONS
PLUG CONNECTOR MATING FACE

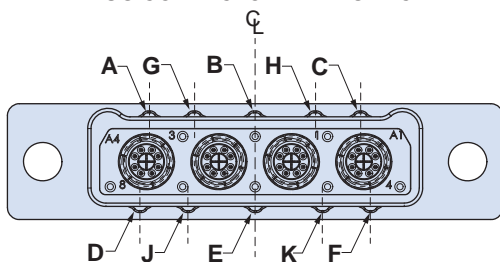

MOD-1104 POLARIZING KEY LOCATIONS
RECEPTACLE CONNECTOR MATING FACE

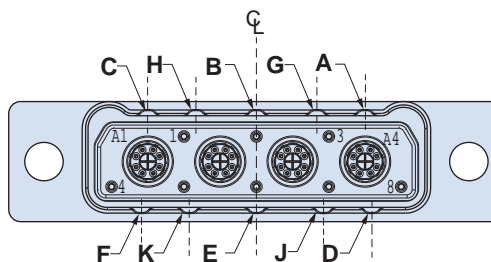

KEY LOCATIONS

Key Position Offset From Vertical Centerline

Shell Size	Position A		Position B		Position C		Position D		Position E		Position F		Position G		Position H		Position J		Position K	
	in	mm	in	mm	in	mm	in	mm	in	mm	in	mm	in	mm	in	mm	in	mm	in	mm
A	.025	0.64	.000	.00	.025	0.64	.100	2.54	.000	.00	.100	2.54	POSITIONS G, H, J AND K ARE NOT AVAILABLE FOR SHELL SIZES A, B AND C							
B	.200	2.29	.000	.00	.200	2.29	.325	8.26	.000	.00	.325	8.26								
C	.375	9.53	.000	.00	.375	9.53	.500	12.70	.000	.00	.500	12.70								
D	.550	13.97	.000	.00	.550	13.97	.600	15.24	.000	.00	.600	15.24	.315	8.00	.315	8.00	.350	8.89	.350	8.89
E	.700	17.78	.000	.00	.700	17.78	.750	19.05	.000	.00	.750	19.05	.315	8.00	.315	8.00	.350	8.89	.350	8.89
F	.700	17.78	.000	.00	.700	17.78	.750	19.05	.000	.00	.750	19.05	.315	8.00	.315	8.00	.350	8.89	.350	8.89

SERIES 792 HIGH-SPEED