

Series 32 Extender Backshells

for MIL-DTL-38999 Series III and IV Connectors

320HS031 Extender Backshell, Composite, Expanded Clearance



Self-Locking

Adapter Code H

This accessory fits these connectors:
MIL-DTL-38999 Series III and Series IV

Self-locking. Extra clearance for #8 contacts. 320HS031 extender backshell fits MIL-DTL-38999 Series III and IV connectors. Extender provides extra clearance for #8 coax, twinax, quadax and octaxial contacts with sealing boots. Back end of extender is identical to connector back end. Attach cable clamp or backshell to back end. Anti-decoupling mechanism provides audible detented coupling and prevents backoff under high vibration. High performance thermoplastic.

PART NUMBER

320HS031 XM 25

Base P/N **320HS031**

Finish	XM Electroless Nickel	<i>Coupling nut is unplated</i>
	XW Cadmium Olive Drab Over Electroless Nickel	
	XB No Plating, Black	
	XO No Plating, Natural	
	XMT 2000 Hour Corrosion Resistant Ni-Ptfe, Nickel-Fluorocarbon Polymer, 1000 Hr Grey	
	XTD 2000 Hour Corrosion Resistant Ni-Ptfe, Nickel-Fluorocarbon Polymer, 1000 Hr Grey - Enhanced	
	XMD 2000 Hour Corrosion Resistant Electroless Nickel - Enhanced	

Shell Size	Shell Size	9	11	13	15	17	19	21	23	25
		A	B	C	D	E	F	G	H	J
	Size Code	09	11	13	15	17	19	21	23	25

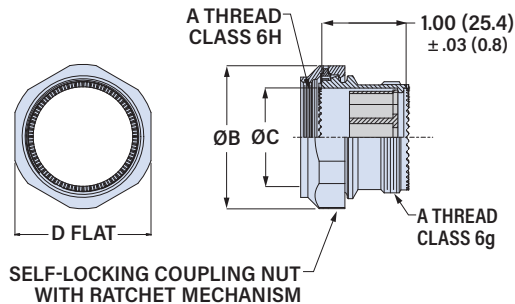

Shell Size	A Thread	ØB Max		ØC Min		D Hex Flats			
		in	mm	in	mm	Max in	Min mm		
9 (A)	M12X1.0	.812	20.6	.304	7.7	.750	19.1	736	18.69
11 (B)	M15X1.0	.938	23.8	.432	11.0	.875	22.2	.860	21.84
13 (C)	M18X1.0	1.125	28.6	.546	13.9	1.000	25.4	.980	24.89
15 (D)	M22X1.0	1.250	31.8	.671	17.0	1.125	28.6	1.100	27.94
17 (E)	M25X1.0	1.375	34.9	.796	20.2	1.250	31.8	1.224	31.09
19 (F)	M28X1.0	1.500	38.1	.902	22.9	1.375	34.9	1.348	34.24
21 (G)	M31X1.0	1.625	41.3	1.027	26.1	1.500	38.1	1.469	37.31
23 (H)	M34X1.0	1.750	44.5	1.152	29.3	1.625	41.3	1.581	40.16
25 (J)	M37X1.0	1.875	47.6	1.287	32.7	1.750	44.5	1.690	42.93