

# WIRING INSTRUCTIONS

FOR IT-FRIT (MIL-DTL-C-5015G) AND ITB-ITS-FRITS (VG95234) CONNECTORS

JUNE 2016



# Wiring Instructions

## for IT - FRIT (MIL-C-5015G) and ITB - ITS - FRITS (VG 95234) Connectors



The aim of this book is to show the users of Glenair's connectors the correct wiring and assembling system of the different piece parts which made up the connector. Following these instructions will permit the less skilled wiring operator to avoid making mistakes which could damage the perfect working as well as the resistance of the connectors to the environmental agents.

The operations described here following are referred to the following connectors families:

**IT - FRIT (MIL-C-5015G)**

**ITB - ITS - FRITS (VG 95234)**

which can be supplied both with crimp and solder contacts.

The following connector descriptions are a general example for each family. For particular requests and versions, electrical and mechanical characteristics, we suggest to consult the catalogues of the different families.

For what is not described in this book or for any further information, please contact our Technical/Designing Office:

**Phone : +39 051 782811**

**Fax : +39 051 782259**

**E-Mail : [designing@glenair.it](mailto:designing@glenair.it)**



## Table of Contents

### Connector Description

IT - FRIT Series.....	4
ITB - ITS - FRITS Series.....	6

### Cable-Contacts Wiring Instructions

Contacts Soldering.....	8
Contacts crimping.....	9
Assembly of a connector and insertion of the crimp contacts.....	12

### Connectors Wiring Instructions

Wiring of single cables.....	18
Wiring of multiple rubber-coated cables .....	20
Wiring of cable with braid shield.....	22
Wiring instructions for additional PHM-EMI adapter.....	24
Wiring instructions for additional PHM-EMI 67 adapter.....	26
Wiring of cable with braid shield and heat shrinkable tubing.....	29
Wiring of cable with thermo-shrinkable tubing.....	30
Wiring of cables with rubber protection tubing (UNI 4883).....	31

### Accessories and Tools.....32

### Crimp Contacts Cross Reference.....33

### Contacts and Assembly Tools

Crimp Contacts Cross Reference.....	37
Insertion and Removal Tools for Pin crimp contacts.....	40
Insertion and Removal Tools for Socket crimp contacts.....	42
Manual and Pneumatic Tools for Pin crimp contacts.....	44
Manual and Pneumatic Tools for Socket crimp contacts.....	46

### Connector Description

#### IT - FRIT Series - Plug Connector

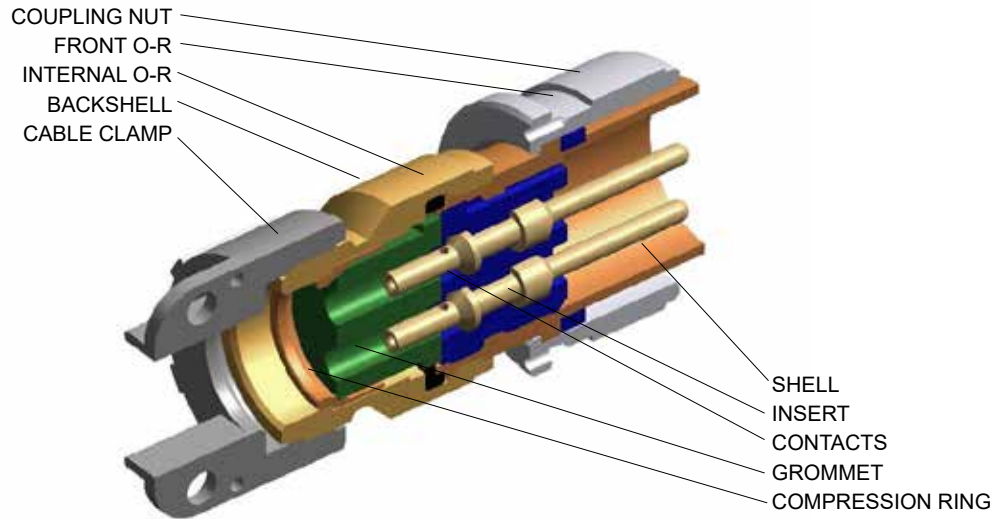

Plug Connector	
Items	Description
Front O-R.	Its function is to guarantee the water tightness after the coupling has already occurred: it is supplied already mounted on the shell (where required) .
Shell	Metallic container for the insulating insert.
Insert	Made of insulating material it divides the contacts one from the other while holding them. It is supplied already mounted in the shell.
Contacts	They are the transmission ways of the signals arriving from the cable. They are available both in crimp and solder versions. In the solder version they are mounted in the insert, in the crimp version they are supplied separately.
Grommet	It protects the ending side of the wired contacts and guarantees the water tightness of the single conductors after the closing of the backshell, but only if their dimensions are the ones required.
Compression Ring	It compresses the grommet on the wiring cables during the screwing of the backshell.
Coupling Nut	It allows the coupling between the plug and the receptacle through the internal thread.
Internal O-R	It guarantees the water tightness between the shell and the backshell.
Backshell	Metallic container. It protects the ending side of the cable and allows to accept each kind of cable clamp thanks to the threaded back side.
Cable clamp	It is used to close the multiple or the single cables. It guarantees the mechanical and water tightness in different styles.

# Wiring Instructions

for IT - FRIT (MIL-DTL-C-5015G) and ITB - ITS - FRITS (VG95234) Connectors



## Connector Description

### IT - FRIT Series - Receptacle Connector

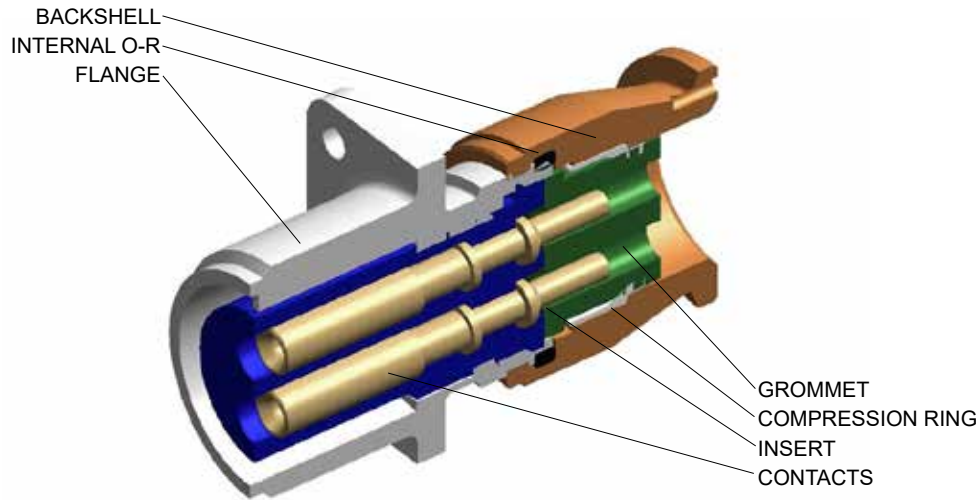

Receptacle Connector	
Items	Description
Flange	Metallic container for the insulating insert.
Insert	Made of insulating material it divides the contacts one from the other while holding them. It is supplied already mounted in the shell.
Contacts	They are the transmission ways of the signals arriving from the cable. They are available both in crimp and solder versions. In the solder version they are mounted in the insert, in the crimp version they are supplied separately.
Grommet	It protects the ending side of the wired contacts and guarantees the water tightness of the single conductors after the closing of the backshell, but only if their dimensions are the ones required.
Compression Ring	It compresses the grommet on the wiring cables during the screwing of the backshell.
Backshell	Metallic container. It protects the ending side of the cable and allows to accept each kind of cable clamp thanks to the threaded back side.

### Connector Description

#### ITB - ITS - FRITS Series - Plug Connector

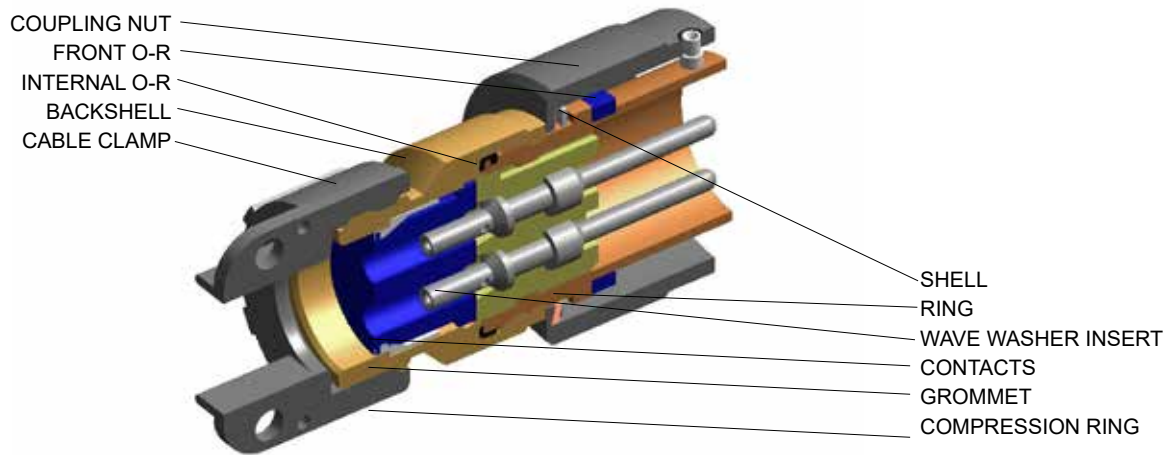

Plug Connector	
Items	Description
Front O-R.	Its function is to guarantee the water tightness after the coupling has already occurred: it is supplied already mounted on the shell.
Shell	Metallic container for the insulating insert.
Insert	Made of insulating material it divides the contacts one from the other while holding them. It is supplied already mounted in the shell.
Contacts	They are the transmission ways of the signals arriving from the cable. They are available both in crimp and solder versions. In the solder version they are mounted in the insert, in the crimp version they are supplied separately.
Grommet	It protects the ending side of the wired contacts and guarantees the water tightness of the single conductors after the closing of the backshell, but only if their dimensions are the ones required.
Compression Ring	It compresses the grommet on the wiring cables during the screwing of the backshell.
Ring	Its function is being the support base of the wave washer .
Wave washer	It avoids the casual disconnection of the plug with the receptacle while compressing the front O-Ring.
Coupling Nut	It enables the coupling between the plug and the receptacle through three stainless steel pins.
Internal O-R	It guarantees the water tightness between the shell and the backshell.
Backshell	Metallic container. It protects the ending side of the cable and allows to accept each kind of cable clamp thanks to the threaded back side.
Cable clamp	It is used to close the multiple or the single cables. It guarantees the mechanical and water tightness in different styles.

# Wiring Instructions

for IT - FRIT (MIL-DTL-C-5015G) and ITB - ITS - FRITS (VG95234) Connectors



## Connector Description

### ITB - ITS - FRITS Series - Receptacle Connector

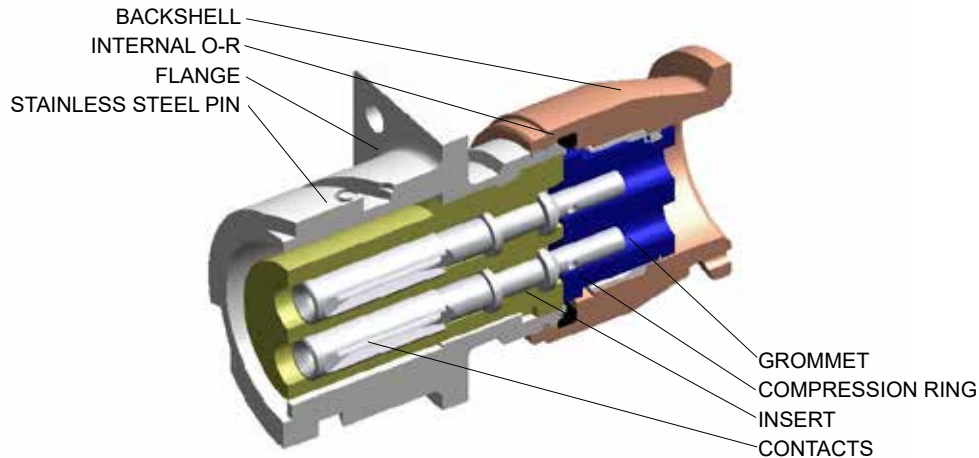

Receptacle Connector	
Items	Description
Flange	Metallic container for the insulating insert.
Insert	Made of insulating material it divides the contacts one from the other while holding them. It is supplied already mounted in the shell.
Contacts	They are the transmission ways of the signals arriving from the cable. They are available both in crimp and solder versions. In the solder version they are mounted in the insert, in the crimp version they are supplied separately.
Grommet	It protects the ending side of the wired contacts and guarantees the water tightness of the single conductors after the closing of the backshell, but only if their dimensions are the ones required.
Compression Ring	It compresses the grommet on the wiring cables during the screwing of the backshell.
Backshell	Metallic container. It protects the ending side of the cable and allows to accept each kind of cable clamp thanks to the threaded back side.

In the ITB version the stainless steel pin is omitted.

### Cable-Contacts Wiring Instructions

#### Soldering

**ATTENTION :** It is necessary to keep in mind that when the water tightness is required by the grommet the external diameter of the conductor has to be sized according to Table I.

Table I			
Connector Type	Contact Size	Ø External cable	
		min.	Max.
IT ITB ITS	16	1.62	3.30
	12	2.89	4.32
	8	4.16	6.47
	4	6.90	9.40
	0	10.54	13.97
Water tightness required according to VG 95234	AWG 16	2.2	2.8
	AWG 12	3.1	3.5
	AWG 8	5.9	6.5
	AWG 4	-	-
	AWG 0	12.1	12.8

After having properly stripped the conductor according to Table II, proceed as follows:



- Foresee a proper pre-tinning of the conductor immersing the half of dimension C in a solution of deoxidizer compound (FLUX) and then the same length in the solder pot depends by the temperature used in the solder pot. The experience and the skill will allow to keep this proportions constant as well as to avoid an excessive immersion of the conductor which would mean a high cable strength.
- Immobilize the connector so that the soldering holes are turned upward and towards the operator. It is suggested to fix the connector to its opposite and this to a clamping.
- Introduce the pre-tinned in the contact hole and warm it until the soldering has melted adding a tin-lead alloy with a deoxidizer core as a filler to improve the fixing.
- After having moved the warm source away from the contact keep the conductor immobile until the soldering has cooled.
- It is suggested to avoid the excess of tin and the excessive warming of the contacts which could compromise the electrical characteristics of the connector.
- It is also suggested to properly size the power of the welding system according to the contacts dimension.
- After the soldering operation carefully clean the parts around the contact in the back side of the insert to remove the excess of tin and deoxidizer.
- With contacts and cables of big dimension it is possible to remove the contacts from the insert and make the soldering operation as previously described in points 1-2-3-4.
- Then insert the contact in the insert after having immobilized the connector according to the suggestions indicated on CABLE-CONTACTS wiring instructions.
- The possible assembly of a heat shrink tubing for the insulation of the contacts must be done after the insertion of the contacts in the insert in order to avoid a wrong placing.
- In connectors of big dimensions ( Size 36 - 40 - 110 ) that require contacts of size 4 , 0 e 4/0 is necessary to control with more attention their correct alignment. In applications with lack of space, it is suggested to use a flexible cable that, always considering its ray of bending, does not have in any way to stress the contact. In this situation the cables must be fixed inside the application. The connector can be supplied with rigid or non-rigid grommets that help the alignment.

Table II: Dimensions		
Contact Size	C (mm)	
	Crimp	Solder
18	4.8	4.0
16S	6.4	6.4
16	6.4	6.4
12	8.5	9.5
8	12.7	12.1
4	12.7	15.9
0	14.0	15.9
4/0	23.2	23.6

Table: Welding Power	
Contact Size	Welding Power
18-16	30 W
12	60 W
8-4-0	300 W

### Cable-Contacts Wiring Instructions

#### Crimping

1. Verify that the contacts are suitable for the conductors in your possession checking the tables on pages 34-41. In case the conductor is not suitable for the contact, a range of reducers is available so to adapt the contact hole to the cable (look at Table III). For requirements not included in the scheme, please contact the Factory.



Reducer

Table III			
Part Number	Contact Size	From wire size	To wire size
10-869-20A-26AG117	20	AWG 20	AWG 26
10-869-16A-22AG10	16	AWG 16	AWG 22
10-869-16A-20AG10	16	AWG 16	AWG 20
10-869-12A-26AG10	12	AWG 12	AWG 26
10-869-12A-20AG10	12	AWG 12	AWG 20
10-869-12A-16AG10	12	AWG 12	AWG 16
10-869-8A-18AG10	8	AWG 8	AWG 18
10-869-8A-16AG10	8	AWG 8	AWG 16
10-869-8A-14AG10	8	AWG 8	AWG 14
10-869-8A-12AG10	8	AWG 8	AWG 12
10-869-8A-10AG10	8	AWG 8	AWG 10
10-869-8A-2.5MG10	8	AWG 8	2,5 mm <sup>2</sup>
10-869-8A-6MG10	8	AWG 8	6 mm <sup>2</sup>
10-869-4A-8AG10	4	AWG 4	AWG 8
10-869-4A-6AG10	4	AWG 4	AWG 6
10-869-4A-16MG10	4	AWG 4	16 mm <sup>2</sup>
10-869-4A-10MG10	4	AWG 4	10 mm <sup>2</sup>
10-869-4A-6MG10	4	AWG 4	6 mm <sup>2</sup>
10-869-4A-2.5MG10	4	AWG 4	2,5 mm <sup>2</sup>
10-869-0A-6AG10	0	AWG 0	AWG 6
10-869-0A-2AG10	0	AWG 0	AWG 2
10-869-0A-50MG10	0	AWG 0	50 mm <sup>2</sup>
10-869-0A-35MG10	0	AWG 0	35 mm <sup>2</sup>
10-869-0A-25MG10	0	AWG 0	25 mm <sup>2</sup>
10-869-0A-16MG10	0	AWG 0	16 mm <sup>2</sup>
10-869-0A-10MG10	0	AWG 0	10 mm <sup>2</sup>

2. Look at tables on pages 34-41 to identify the tooling for the crimping according to the contact (crimping tool-turret-insertion tool-removal tool...).

- 3A. Mount the turret on the crimping tool





### Cable-Contacts Wiring Instructions

#### Crimping

7. Move the crimped contact away and check that:
- no strands come out of the contact.
  - no conductor is seen from the inspection hole.
  - the sheath rests on the contact.
  - no breaks are present near the deforming side.
  - the mechanical tightness of the contact on the conductor is according to Table IV.

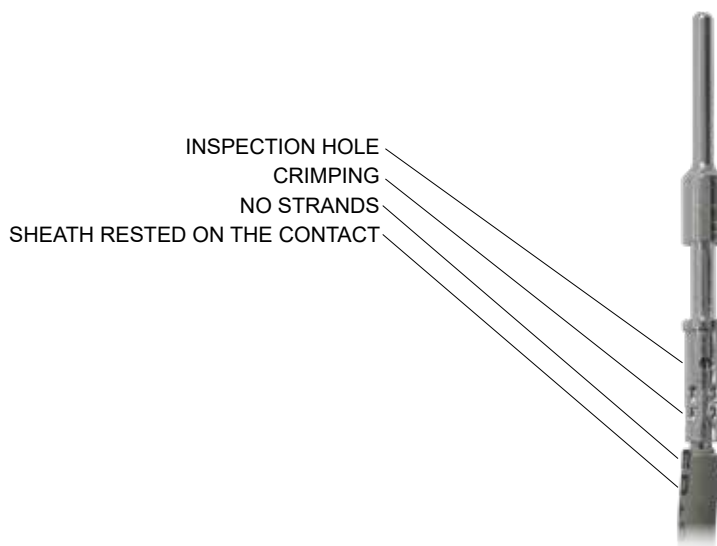

Cable AWG	Section mm <sup>2</sup>	Min. conductor tightness	
		Ag + Sn	Ni
4/0	107	4337 N	3492 N
0	53	3114 N	2802 N
4	22	1779 N	1604 N
8	9	979 N	890 N
12	3	489 N	445 N
16	1.2	222 N	165 N
20	0.7	89 N	85 N

### Cable-Contacts Wiring Instructions

#### Assembly of a connector and insertion of the crimp contacts

To introduce the contacts in the insert use the insertion tool according to tables on pages 34-41.

1. Make all the components (backshell, compression ring and other backshell accessory) of the connector slide according to the opposite sequence of the one of the assembly. Lock the components with an adhesive tape. Immobilize the connector so that the soldering holes are turned upward and towards the operator. It is suggested to fix the connector to its opposite and this to a clamping.



2. Insert the conductors in the grommet (where required) paying attention to the letters or numbers present in the back side in order to align them with the same ones of the insert. Use little quantities of alcohol on the insert to facilitate the insertion operation



3. Stripped the conductor by a wire strip according to table below:

Table: Dimensions		
Contact Size	C (mm)	
	Crimp	Solder
18	4.8	4.0
16S	6.4	6.4
16	6.4	6.4
12	8.5	9.5
8	12.7	12.1
4	12.7	15.9
0	14.0	15.9
4/0	23.2	23.6

# Wiring Instructions

for IT - FRIT (MIL-DTL-C-5015G) and ITB - ITS - FRITS (VG95234) Connectors



## Cable-Contacts Wiring Instructions

### Assembly of a connector and insertion of the crimp contacts

- Put the stripped cable inside the crimp bucket of the contact, than introduce the contact in the crimp tool and crimp the contact. Repeat the procedure the the points 3 and 4 for all the contacts.
- Place the connector to wire on its opposite or in a dummy connector in a fixed position so to facilitate the insertion effort.



- Use little quantities of alcohol on the insert to facilitate the insertion operation.



- Place the contact in the insertion tool making resting the crimping tool on the crimping ledge for a stronger hold. To introduce the female contact the ogives shall be used (look at tables on pages 36-37) to facilitate the insertion and avoid the breaking of the insert/grommet. At the end of the operation the ogive is removed from the front side of the connector.



### Cable-Contacts Wiring Instructions

#### Assembly of a connector and insertion of the crimp contacts

8. Introduce the contact from the back side of the insert exercising a slow but constant force until the definitive position is reached. For contacts size 16 and 12 the insertion tool has a safety ledge; making resting the ledge of the crimping tool on the back side of the insert, the correct position of the contact is immediately reached; this position is stressed by the reduction of the rubber resistance. Continuing to pull the contact beyond the aforesaid limit a new strong resistance force is noticed. It advise the passing over of the optimal position of the contact. Do this operation with the maximum care exclusively operating on the longitudinal axis of the connector avoiding any oblique and rotating movements.



It is advisable to introduce all the contacts in the connector, the not used, too, or to replace them with the suitable sealing plugs.

When all the contacts have been inserted check their position from the front side to verify their correct alignment.



Check Table V and Table VI to verify the right position of the contacts.

# Wiring Instructions

for IT - FRIT (MIL-DTL-C-5015G) and ITB - ITS - FRITS (VG95234) Connectors



## Cable-Contacts Wiring Instructions

### Assembly of a connector and insertion of the crimp contacts

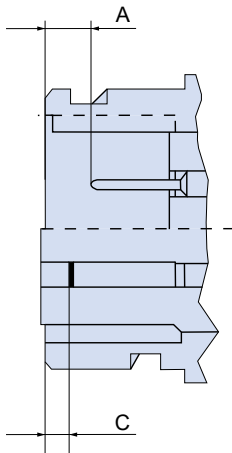

Table V: Contact Size																		
Size	A±1									C±1								
	Male Contact Size									Female Contact Size								
	20	18	16S	16	12	8	4	0	4/0	20	18	16S	16	12	8	4	0	4/0
10SL			3,5															
14S			3,5															
16S			3,5															
16		7,3		7,1	2,4	2,4	3,1	2,6			2,3		2,4	2,4	2,4	2,4	2,6	
18		7,3		7,1	2,4	2,4	3,1	2,6			2,3		2,4	2,4	2,4	2,4	2,6	
20		7,3		7,1	2,4	2,4	3,1	2,6			2,3		2,4	2,4	2,4	2,4	2,6	
22		7,3		7,1	2,4	2,4	3,1	2,6			2,3		2,4	2,4	2,4	2,4	2,6	
24	10,3			7,1	2,4	2,4	3,1	2,6		2,1			2,4	2,4	2,4	2,4	2,6	
28	10,3			7,1	2,4	2,4	3,1	2,6		2,1			2,4	2,4	2,4	2,4	2,6	
32	10,3			7,1	2,4	2,4	3,1	2,6	3,6	2,1			2,4	2,4	2,4	2,4	2,6	0,3
36	10,3	6,7		7,1	2,4	2,4	3,1	2,6	3,6	2,1	2		2,4	2,4	2,4	2,4	2,6	0,3
40		6,7		7,1	2,4	2,4	3,1	2,6	3,6		2		2,4	2,4	2,4	2,4	2,6	0,3

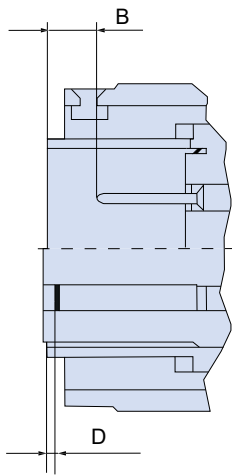

Table VI: Contact Size																		
Size	B±1									D±1								
	Male Contact Size									Female Contact Size								
	20	18	16S	16	12	8	4	0	4/0	20	18	16S	16	12	8	4	0	4/0
10SL			2,7															
14S			2,7															
16S			2,7															
16		7,3		7,1	2,4	2,4	3,1	2,6			2,3		2,4	2,4	2,4	2,4	2,6	
18		7,3		7,1	2,4	2,4	3,1	2,6			2,3		2,4	2,4	2,4	2,4	2,6	
20		7,3		7,1	2,4	2,4	3,1	2,6			2,3		2,4	2,4	2,4	2,4	2,6	
22		7,3		7,1	2,4	2,4	3,1	2,6			2,3		2,4	2,4	2,4	2,4	2,6	
24	10,3			7,1	2,4	2,4	3,1	2,6		2,1			2,4	2,4	2,4	2,4	2,6	
28	10,3			7,1	2,4	2,4	3,1	2,6		2,1			2,4	2,4	2,4	2,4	2,6	
32	10,3			7,1	2,4	2,4	3,1	2,6	3,6	2,1			2,4	2,4	2,4	2,4	2,6	0,3
36	10,3	6,7		7,1	2,4	2,4	3,1	2,6	3,6	2,1	2		2,4	2,4	2,4	2,4	2,6	0,3
40		6,7		7,1	2,4	2,4	3,1	2,6	3,6		2		2,4	2,4	2,4	2,4	2,6	0,3

### Cable-Contacts Wiring Instructions

#### Assembly of a connector and insertion of the crimp contacts

If some contacts are inserted too deeply, a little opposite pull with the right extraction tool will help to place them in the right position .



**9.** Dry and wait until the connector is dried from the alcohol, the presence of alcohol damage the insulating resistance of the connectors.

**10.** If the connector have many contacts is very difficult to pass through the grommet with all the wires then insert the contact inside the insert and place in position the grommet, in this situation it may be possible to insert the contact in the insert directly through the grommet. Use a moderate quantity of alcohol on the insert and on the grommet, place the grommet in position with the letters / numbers aligned with the insert, then introduce the contact from the back side of the grommet exercising a slow but constant force until the definitive position is reached. Do this operation with the maximum care exclusively operating on the longitudinal axis of the connector avoiding any oblique and rotating movements that can damages the grommet. Dry and wait until the connector is dried from the alcohol, the presence of alcohol damage the insulating resistance of the connectors.

**11.** Put a moderate quantity of grease on the grommet.



**12.** Slide down the compression ring, put a moderate quantity of grease on the compression ring. Put a moderate quantity of grease on the receptacle/shell thread.



### Cable-Contacts Wiring Instructions

#### Assembly of a connector and insertion of the crimp contacts

13. Slide down the backshell, screw the backshell on the shell (or receptacle) with TG70 strap wrench and a dynamometric key. The locking force to apply for the assembly of backshells is below:



Shell Size	Applied force (Nm)	
	min.	Max.
10SL	1.5	2.5
14S	4.4	5.4
16S	6.4	7.4
16	6.4	7.4
18	6.9	7.8
20	7.8	9.8
22	9.8	11.8
24	10.8	14.7
28	13.7	18.6
32	14.7	20.6
36	18.6	26.5
40	20.6	39.2

14. To extract the contact from the insert use the extraction tools according to tables on pages 34-41. Exercise a slow but constant force on the contact from the front side of the insert until the contact comes out. Pay attention to exercise the force on the longitudinal axis of the connector avoiding oblique movements.



### Connectors Wiring Instructions

#### Wiring instructions of the connectors single cables

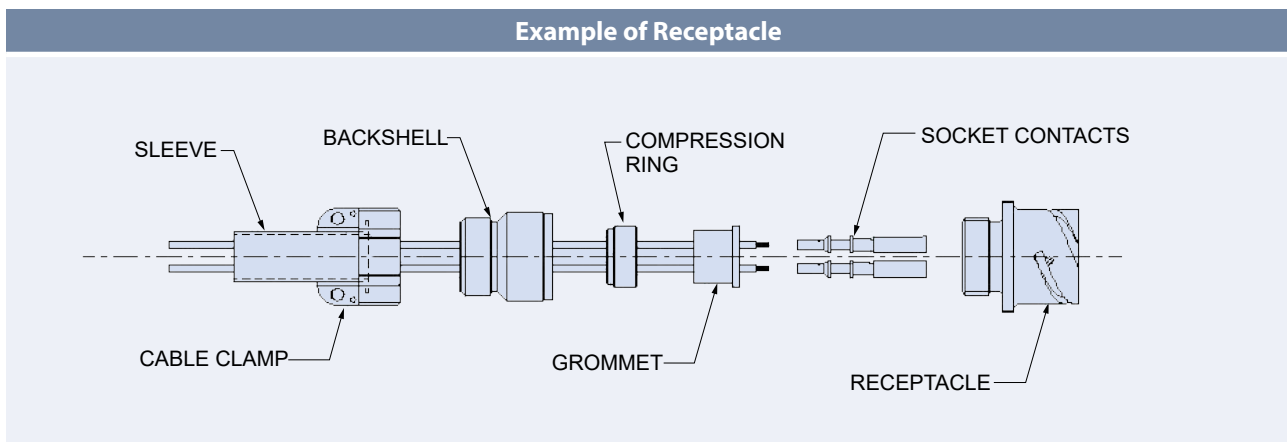
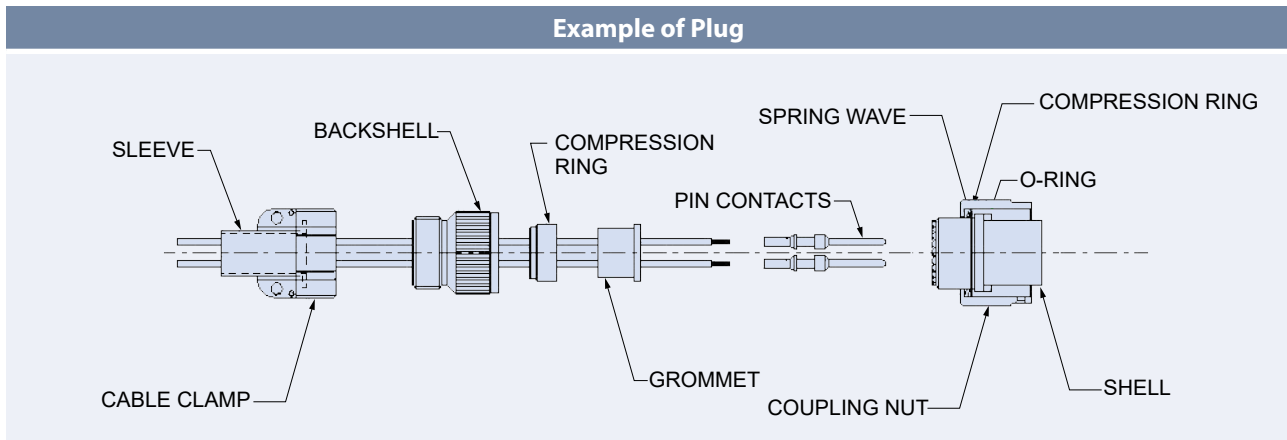

1. Make all the components of the connector slide according to the opposite sequence of the one of the assembly (See pictures above).
2. Insert the conductors in the grommet (where required) paying attention to the letters or numbers present in the back side in order to align them with the same ones of the insert.
3. Cut the conductors according to Table II of page 8 using a proper tool paying attention not to cut any strand
4. Start the crimping (See pages 10-11) or soldering (See page 8) of the contact.
5. In the crimp version insert the contacts following the instructions of pages 12-15.
6. In case lubricant are used to facilitate the insertion of the contacts, carefully clean the insulating parts.
7. Assemble the components as follows :
  - 7.1 PLUG  
Bring on the shell in sequence the ring, the wave washer, the coupling nut paying attention that the cut of the wave washer is beard on the ring and mate the connector to a fixed counterside to facilitate the assembly.
  - 7.2 RECEPTACLE  
Lock the flange paying attention not to damage it.
8. Put behind the insert the grommet and the compression ring in sequence.

### Connectors Wiring Instructions

#### Wiring instructions of the connectors single cables

9. Check that the internal O-ring (where required) is lubricated and in the correct position.
10. Screw the backshell on the shell (or receptacle) with protected closing pliers type M. 120001 and M. 12002 to avoid to damage the external plating. The locking force to apply for the assembly of backshells and cable clamps can be consulted on Table VII.
11. Bring the sleeve (if present) closer to the backshell. Screw the cable clamp to the backshell according to the previous shrewdness consulting TableVII.
12. Screw the screws of the saddle clamps (if required) up to guarantee asufficient mechanical tightness of the cable.

Table VII: Locking forces		
Shell Size	Applied force (Nm)	
	Min.	Max.
10SL	1.5	2.5
14S	4.4	5.4
16S	6.4	7.4
16	6.4	7.4
18	6.9	7.8
20	7.8	9.8
22	9.8	11.8
24	10.8	14.7
28	13.7	18.6
32	14.7	20.6
36	18.6	26.5
40	20.6	39.2

Cable Clamp Torque Values		
Clamp Size	With Grommet In-Lbs (Min/Max)	Without Grommet In-Lbs (Min/Max)
3	8/12	30/40
4	10/15	30/40
6	10/15	35/55
8	12/20	35/55
10	12/20	35/55
12	15/30	40/60
16	20/40	40/60
20	20/40	40/60
24	25/45	80/100
28	30/50	80/100
32	30/50	80/100
40	40/60	80/100

Torque Values for Cable Clamp Screws	
Screw Size	In-Lbs (Min/Max)
2-56	1.5/2.5
4-40	3.5/4.5
6-32	5.0/7.0
8-32	7.0/9.0
10-32	9.0/11.0
.250-20	11.0/13.0

# Wiring Instructions

for IT - FRIT (MIL-DTL-C-5015G) and ITB - ITS - FRITS (VG95234) Connectors



## Connectors Wiring Instructions

Multiple rubber-coated cables

### Example of Plug

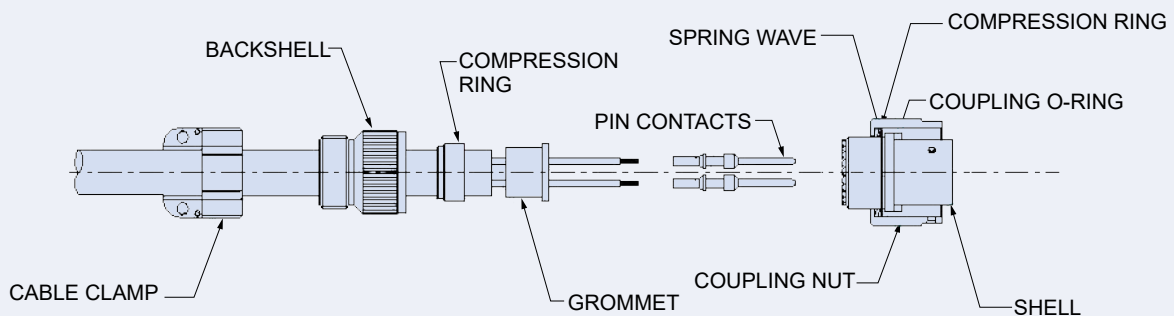

### Example of Receptacle

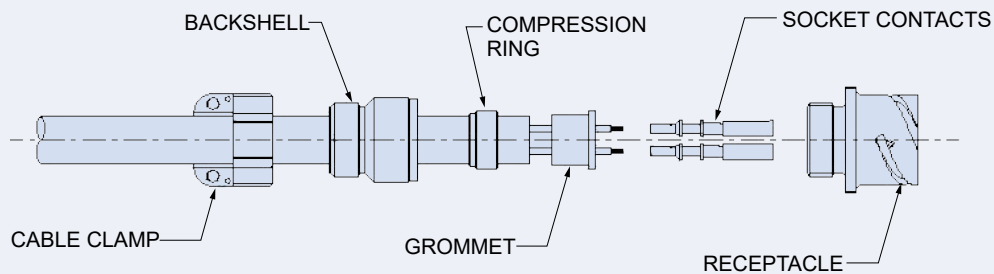

1. Unsheathe the cable like in picture below.

### Cable unsheathing

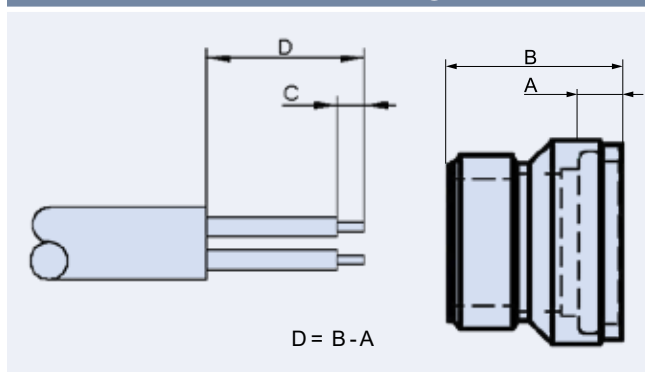

### Connectors Wiring Instructions

#### Multiple rubber-coated cables

2. Make all the components of the connector slide according to the opposite sequence of the one of the assembly ( See figures on page 20).
3. Insert the conductors in the grommet (where required) paying attention to the letters or numbers present in the back side in order to align them with the same ones of the insert.
4. Cut the cables according to Table II of page 8 using a proper tool paying attention not to cut any strand.
5. Start the crimping (See pages 10-11) or soldering (See page 8) of the contact.
6. In the crimp version insert the contacts following the instructions of pages 12-15.
7. In case lubricant are used to facilitate the insertion of the contacts, carefully clean the insulating parts.
8. Assemble the components as follows :
  - 8.1) PLUG  
Bring on the shell in sequence the ring, the wave washer, the coupling nut paying attention that the cut of the wave washer is beard on the ring and mate the connector to a fixed counterside to facilitate the assembly.
  - 8.2) RECEPTACLE  
Lock the flange paying attention not to damage it.
9. Put behind the insert the grommet and the compression ring in sequence.
10. Check that the internal O-ring (where required) is lubricated and in the correct position.
11. Screw the backshell on the shell (or receptacle) with protected closing pliers type M. 120001 and M. 12002 to avoid to damage the external plating. The locking force to apply for the assembly of backshells and cable clamps can be consulted on Table VII on page 19.
12. Bring the sleeve (if present) closer to the backshell. Screw the cable clamp to the backshell according to the previous shrewdness consulting Table VII.
13. Screw the screws of the saddle clamps (if required) up to guarantee a sufficient mechanical tightness of the cable.

### Connectors Wiring Instructions

#### Cables with braid shield

The use of these cables is necessary when an EMI or RFI protection is required. Here following we describe the procedures for the wiring of a connector suitable for this kind of cable.

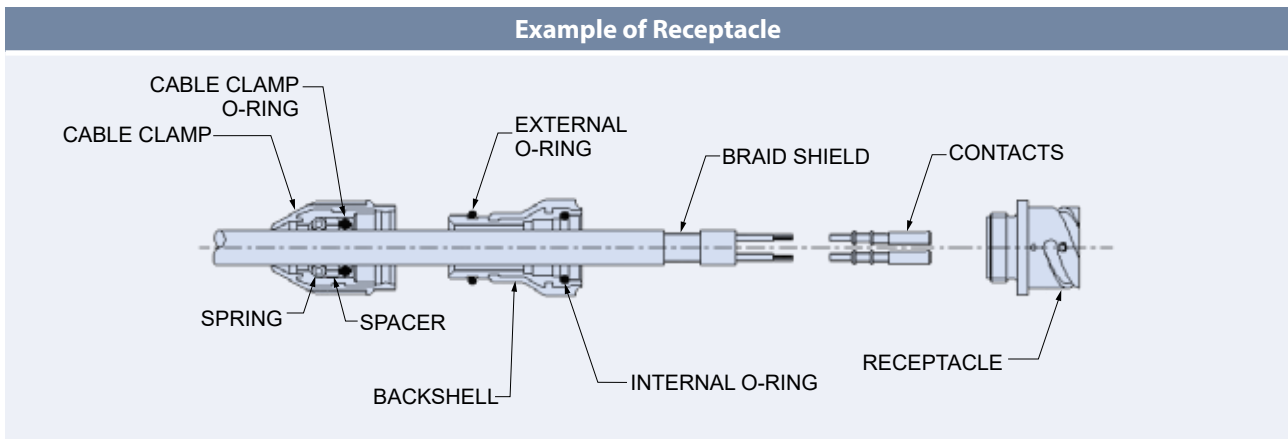
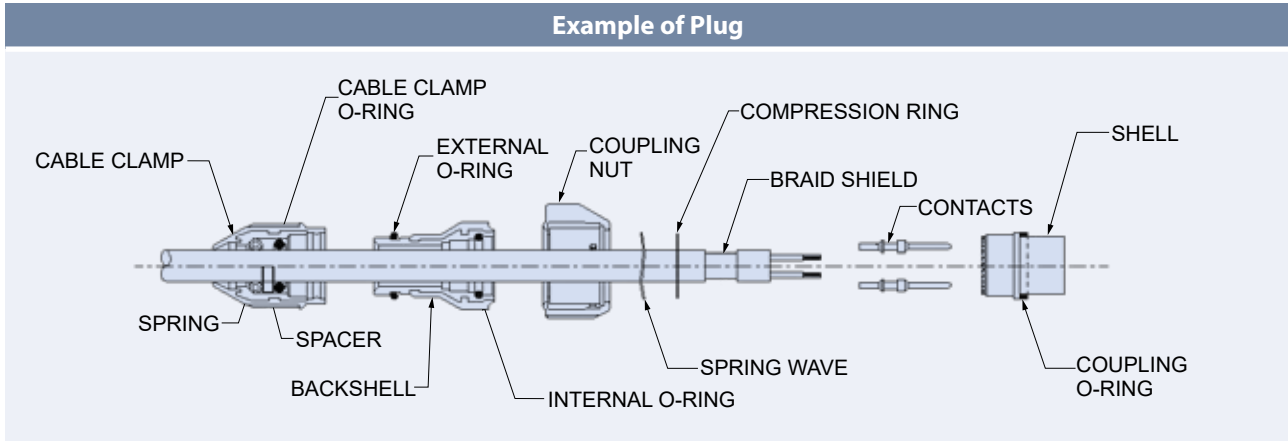

1. Unsheathe the cable like in picture below.

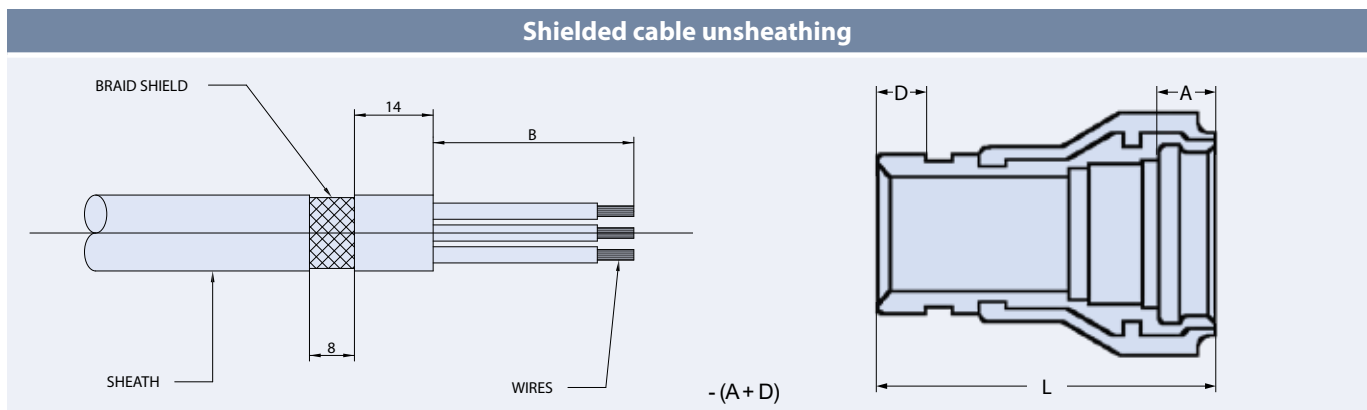

2. Cut the external sheath according to the dimensions indicated in picture above (receptacle) in order to uncover the braid shield. This operation must be performed with the max. care in order to uncut the strands of the braid itself.

### Connectors Wiring Instructions

#### Cables with braid shield

3. Make all the components of the connector slide according to the opposite sequence of the one of the assembly ( See pictures on page 22 ).
4. Start the crimping (See pages 10-11) or soldering (See page 8) of the contact.
5. In the crimp version insert the contacts following the instructions of pages 12-15.
6. In case lubricant are used to facilitate the insertion of the contacts, carefully clean the insulating parts.
7. Assemble the components as follows :
  - 7.1 PLUG  
Bring on the shell in sequence the ring, the wave washer, the coupling nut paying attention that the cut of the wave washer is beard on the ring and mate the connector to a fixed counterside to facilitate the assembly.
  - 7.2 RECEPTACLE  
Lock the flange paying attention not to damage it.
8. Put behind the insert the grommet and the compression ring in sequence.
9. Check that the internal O-ring (where required) is lubricated and in the correct position.
10. Screw the backshell on the shell (or receptacle) with protected closing pliers type M. 120001 and M. 12002 to avoid to damage the external plating.
11. Put the backshell behind the cable clamp with washer, spacer and cable clamp OR in a correct position and screw with strength with a closing strength as indicated on Table VII on page 19.

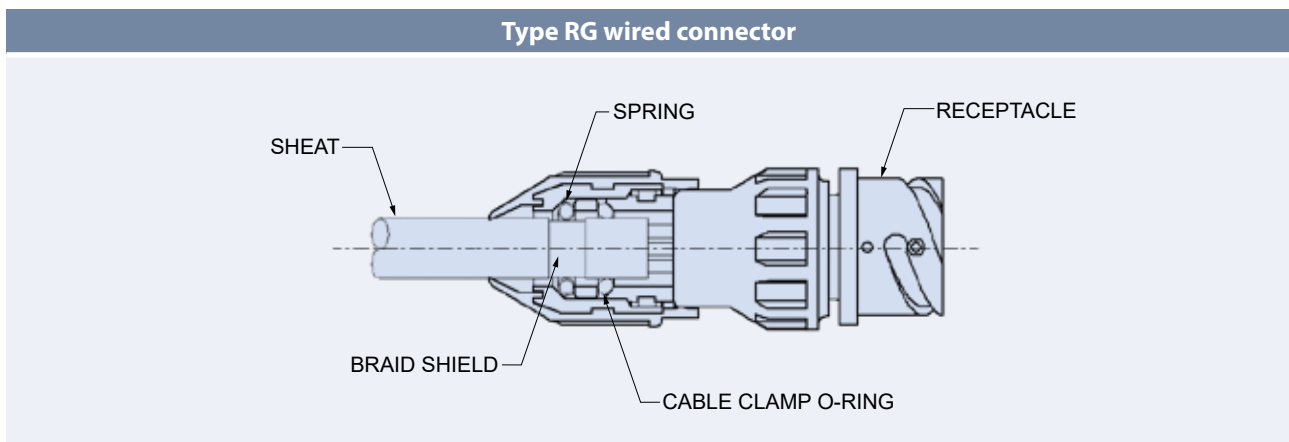

# Wiring Instructions

for IT - FRIT (MIL-DTL-C-5015G) and ITB - ITS - FRITS (VG95234) Connectors



## Connectors Wiring Instructions

### Wiring instructions for additional PHM-EMI adapter

Components
01. Front group
02. Inner cone
03. External cone
04. Backshell
05. Plastic clamp
06. Bushing
07. Cable gland rear nut

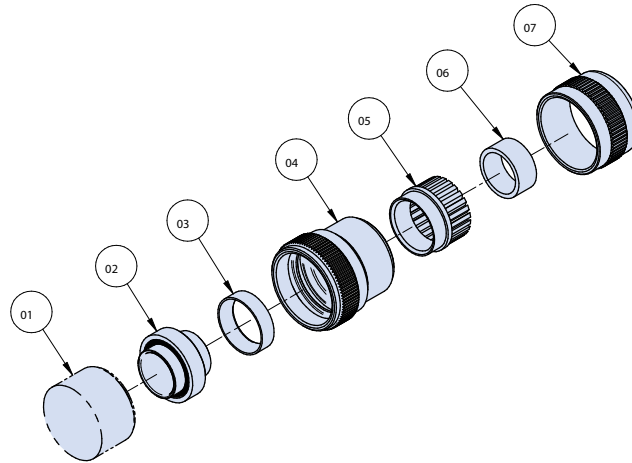

**Phase 1.** Fit on the cable components: Inner cone (02), External cone (03), Backshell (04), Plastic clamp (05), Bushing (06), Cable gland rear nut (07)

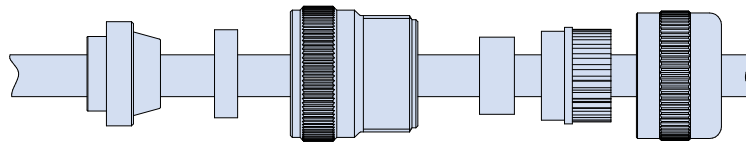

**Phase 2.** Strip the cable as below indicated. For "X" dimension please follow standard contacts harnessing instructions.

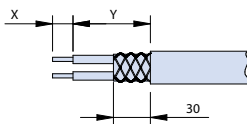

Size	Z
20	19
24	21

Y= cable inside the backshell until its end +Z

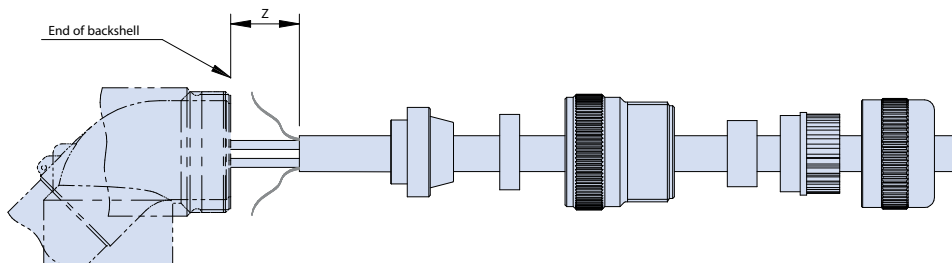

# Wiring Instructions

for IT - FRIT (MIL-DTL-C-5015G) and ITB - ITS - FRITS (VG95234) Connectors



## Connectors Wiring Instructions

### Wiring instructions for additional PHM-EMI adapter

**Phase 3.** Fold back the braid and fix it with a strip of tape.

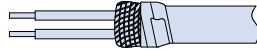

**Phase 4.** Follow standard harnessing instruction and fit all the contacts in the insert.

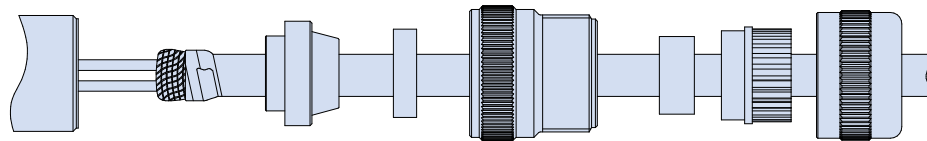

**Phase 5.** Slide Inner cone (02) until reaching the Front group (01).

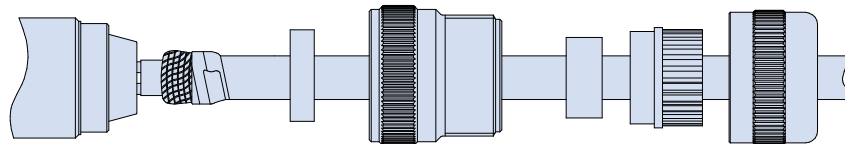

**Phase 6.** Take off the tape, fold the braid over the Inner cone (02) and slide the External cone (03) as below indicated. Cut off the braid excess.

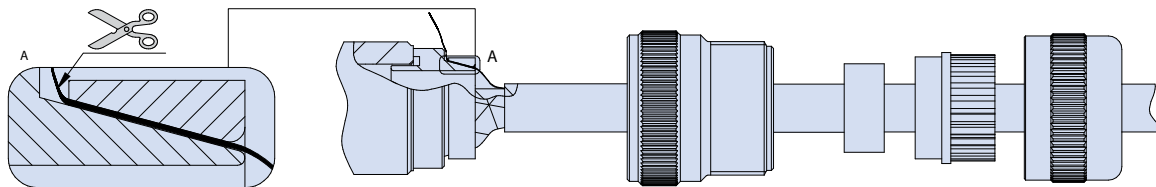

**Phase 7.** Slide and fit the Plastic clamp (06) and the Bushing (07).

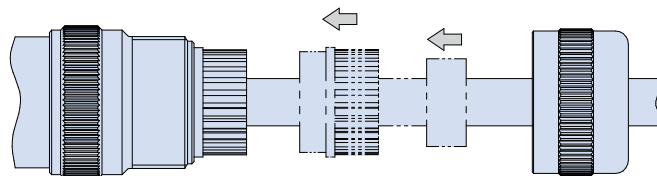

**Phase 8.** Slide, screw and close the Cable gland rear nut (08).

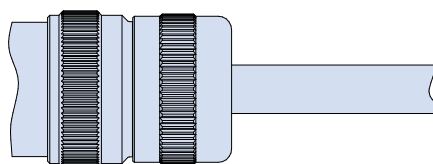

# Wiring Instructions

for IT - FRIT (MIL-DTL-C-5015G) and ITB - ITS - FRITS (VG95234) Connectors



## Connectors Wiring Instructions

Wiring instructions for additional PHM-EMI 67 adapter

Components
01. Front group (coupling nut, shell, insert and contact)
02. Connecting cable (not supplied)
03. Metallic sleeve (non conductive plated metal)
04. Braid trap (metal)
05. Backshell (metal)
06. Rear gasket (rubber)
07. Cable clamp (plastic)
08. Rubber sleeve for the cable clamp (rubber)
09. Coupling nut for the clamp (metal)
10. Extension (optional)

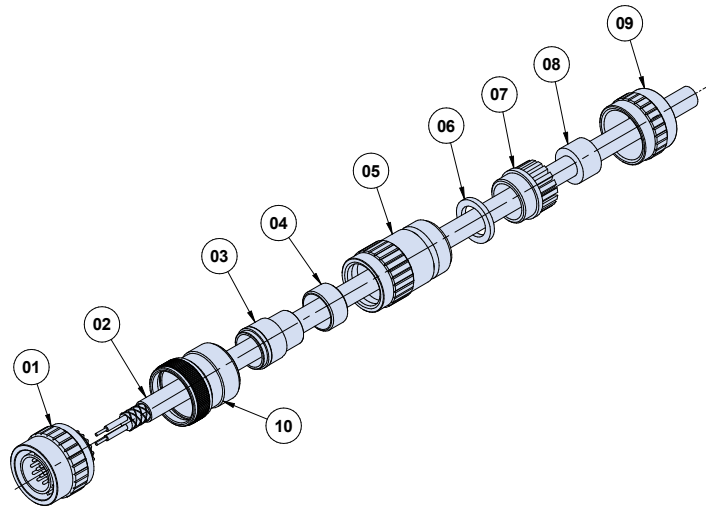

**Note**

1. In some sizes, the rear gasket (06) can be supplied as an oring type installed in the backshell (05)
2. The extension is suggested in case of difficult harnesses. For part number, see Table I below.

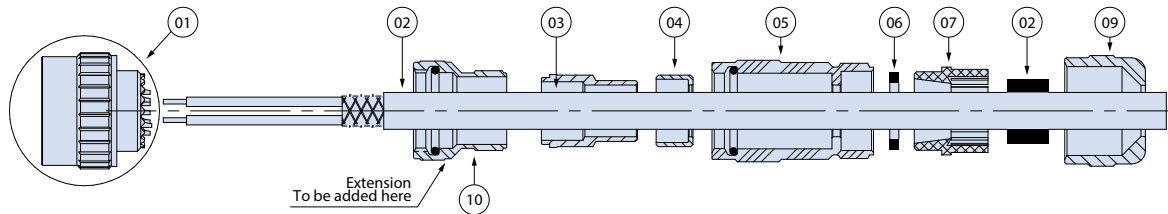

Choose Extension part number.

Connector Size	Part Number
14S	PRL-14S
16S	PRL-16S
16	PRL-16
18	PRL-18
20	PRL-20
22	PRL-22
24	PRL-24
28	PRL-28
32	PRL-32

**Phase 1.** Put all the parts of the connectors in sequence on the cable as indicated in the scheme above. If an extension is going to be used, insert it last as shown.

# Wiring Instructions

for IT - FRIT (MIL-DTL-C-5015G) and ITB - ITS - FRITS (VG95234) Connectors



## Connectors Wiring Instructions

### Wiring instructions for additional PHM-EMI 67 adapter

**Phase 2.** Strip the cable based on the contact and connector size to the dimension A indicated in the Table II taking care not to cut or nick the braid and then cut all fillers and wraps. For cables with different wire sizes, choose the strip length for the longest wire (largest wire size) C in Table III for the formula for A in Table II. Also if ITEM 10, Extension is used, add the additional length dimension "+Extension [mm]" in Table IV. This dimension will replace the length A in Table I. Fold back the braid on the outer jacket and tape it down (it's also possible to comb the braid for a more even distribution around the cable). If there are internal braid covered wires, comb the braid and fold over the outer braid evenly and tape it the same time as the outer braid. Finally strip the individual wires according to the contact size or wire size if it is different using the dimension C in the Table III maintaining the lengths in Table IV, B dimension accordingly on the individual wires.

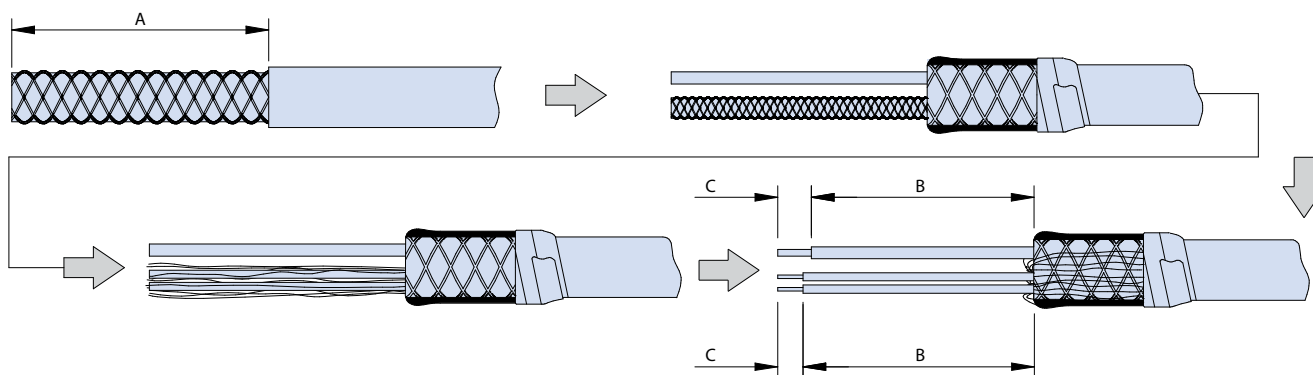

Connector Size	A (mm)
14S / 16S / 16 / 18	22+ "C" + *
20 / 22	25+ "C" + *
24 / 28	30+ "C" + *
32	39+ "C" + *
* = if using an extension also add the "+ extension" length (Table IV).	

Contact Size	C Solder (mm)	C Crimp (mm)
18	4	4.8
16 / 16S	6.4	6.4
12	9.5	8.5
8	12.1	12.7
4	15.9	12.7
0	15.9	14

**Note**

- For dimension "C", if the wire size used in the contact is smaller than the contact size (contacts with reduced crimp buckets) use the contact length that comes the closest to the wire size, for instance, a 14 AWG wire will be stripped to the length for a contact size 12, 8.5 mm for crimp.

		Table IV																	
		Size	14S	16S	16	18	20	22	24	28	32								
		PHM	11	11	11	11	18	11	18	18	18	22	24	18	22	24	22	24	
B (mm)	Contact size	18	-	-	20.2	-	-	-	-	23.3	-	-	-	-	-	-	-	-	-
		16 / 16S	18.2	16	17.8	18.2	18.4	20.4	20.9	20.9	24.2	23.9	24.2	24.2	24.2	24.2	24.2	33.7	33.7
		12	17	14.8	16.6	17.0	17.2	19.2	19.7	19.7	23.0	22.7	23.0	23.0	23.0	23.0	32.5	32.5	
		8	-	-	12.3	12.7	12.9	14.9	15.4	15.4	18.7	18.4	18.7	18.7	18.7	18.7	28.2	28.2	
		4	-	-	12.3	12.7	12.9	14.9	15.4	15.4	18.7	18.4	18.7	18.7	18.7	18.7	28.2	28.2	
		0	-	-	8.9	9.3	9.5	11.5	12.0	12.0	15.3	15.0	15.3	15.3	15.3	15.3	24.8	24.8	
+ Extension (mm)			+ 40				+ 50				+ 60								
"+ Extension" needs to be added for each wire if using an extension																			

**Phase 3.** Crimp version- Crimp the contacts onto the relative conductors and install them into the appropriate cavity in the insert. Solder version- Solder the conductors on the relative contacts that are already installed in the insert.

# Wiring Instructions

for IT - FRIT (MIL-DTL-C-5015G) and ITB - ITS - FRITS (VG95234) Connectors



## Connectors Wiring Instructions

### Wiring instructions for additional PHM-EMI 67 adapter

**Phase 4.** With the extension- Slide and screw the extension to the shell, then torque to the recommended torque value in Table V. Take the metallic sleeve (03) and slide until its front side makes contact with the extension. Without extension- Take the metallic sleeve (03) and slide until its front side makes contact with the shell.

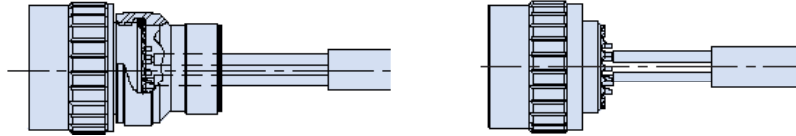

**Phase 5.** Unwrap the braid and fold it onto the metallic sleeve (03). Put the braid trap (04) on the metallic sleeve (03) and cut off the excess.

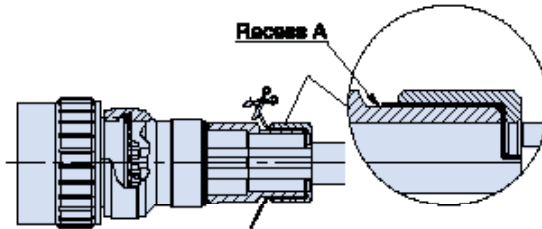

#### Note

1. Recess A indicated in the picture is required to contain any excess braid exiting the braid trap. In any case it is suggested to cut it short enough to fit in this area in order to avoid interference during assembly.

**Phase 6.** Screw the backshell (05) and tighten to the recommended torque value in Table V.

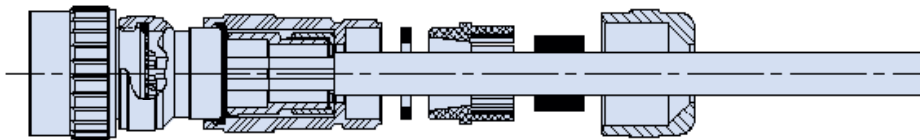
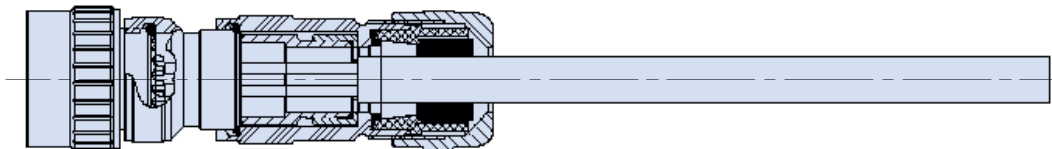

Table V

Shell Size	Torque (Nm)
14S	5
16S	7
16	7
18	8
20	9
22	11
24	13
28	17
32	18

**Phase 7.** Take the back gasket (06) and slide it down the cable until it enters in the backshell (05) then take the clamp (07) and push it against the gasket or until it bottoms into the backshell. Insert the rubber sleeve (08) sliding it on the cable and force it inside the fingers of the clamp until it is seated.

**Phase 8.** Lock everything by screwing the coupling nut (09) and compress the sleeve until there is sufficient grip on the cable.



### Connectors Wiring Instructions

#### Multiple rubber-coated cables with braid shield and thermo-shrinkable tubing

The use of these cables is necessary when an EMI or RFI protection is required. Here following we describe the procedures for the wiring of a connector suitable for this kind of cable. The SP type differs from the RG type because of the different closing of the braid shield.

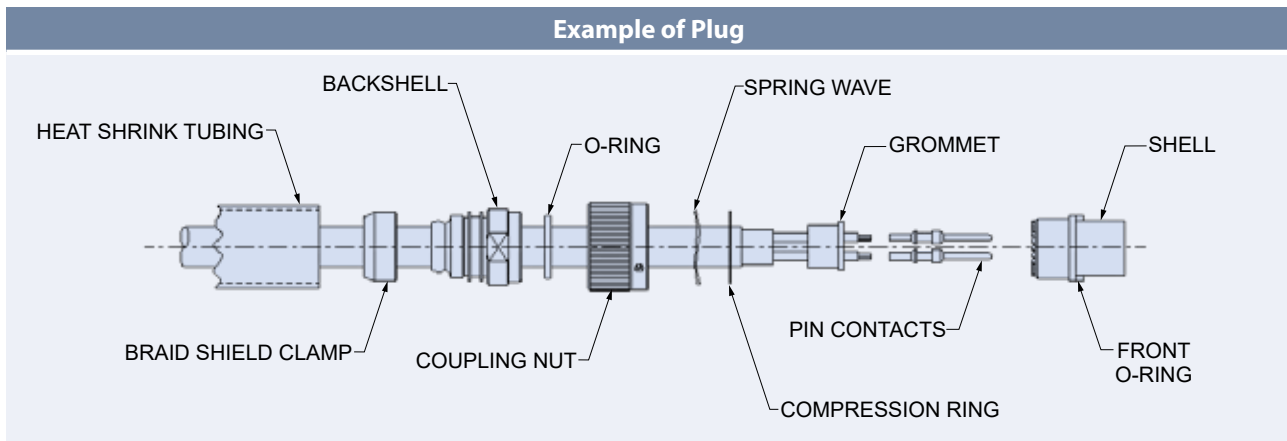

1. Unsheathe the cable up to get dimension X and dimension Y as indicated on Table 8 paying attention not to cut the strands of the braid.

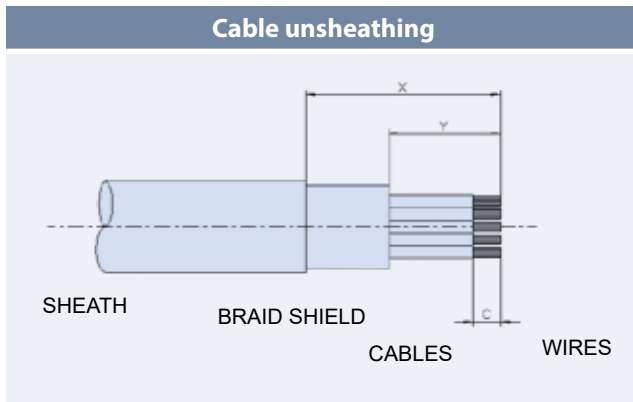

Connector Size	X	Y
10SL	53	23.0
14S	53	23.0
16S	53	24.5
16	68	28.5
18	68	28.5
20	75	28.5
22	75	28.5
24	75	28.5
28	75	28.5
32	75	28.5
36	75	28.5
40	75	28.5

2. Make all the components of the connector slide according to the opposite sequence of the one of the assembly ( See picture above ).
3. Insert the conductors in the grommet (where required) paying attention to the letters or numbers present in the back side in order to align them with the same ones of the insert.
4. Cut the cables according to Table II of page 8 using a proper tool paying attention not to cut any strand .
5. Start the crimping (See pages 10-11) or soldering (See page 8) of the contact .
6. In the crimp version insert the contacts following the instructions of pages 12-15.
7. In case lubricant are used to facilitate the insertion of the contacts, carefully clean the insulating parts.
8. Assemble the components as follows :
  - 8.1) PLUG
 

Bring on the shell in sequence the ring, the wave washer, the coupling nut paying attention that the cut of the wave washer is beard on the ring and mate the connector to a fixed counterside to facilitate the assembly.
  - 8.2) RECEPTACLE
 

Lock the flange paying attention not to damage it.

### Connectors Wiring Instructions

#### Multiple rubber-coated cables with braid shield and thermo-shrinkable tubing

9. Put behind the insert the grommet and the compression ring in sequence .
10. Check that the internal O-ring (where required) is lubricated and in the correct position.
11. Screw the backshell on the shell (or receptacle) with protected closing pliers type M. 120001 and M. 12002 to avoid to damage the external plating. The locking force to apply for the assembly of backshells and cable clamps can be consulted on Table VII on page 19.
12. Put the braid on the conical part of the backshell and fix it through a wire in stainless steel. This wire must be put in the proper seat between the conical part and the thread. At the end of this operation make sure that the wire or the braid do not interfere with the thread (see picture below).

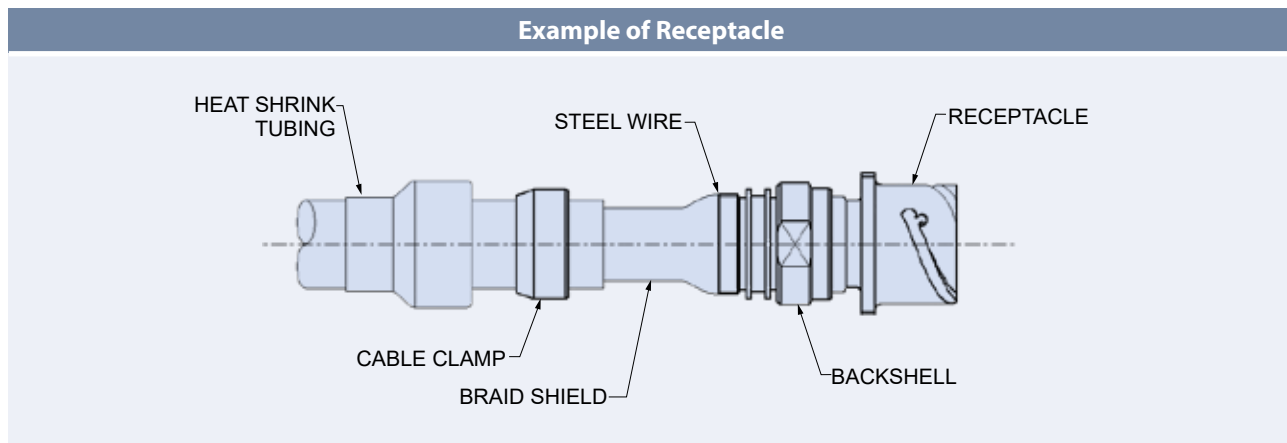

13. Screw the backshell on the shell (or receptacle) with protected closing pliers type M. 120001 and M. 12002 to avoid to damage the external plating.
14. Put on the thermoshrinkable tubing or the moulded shapes on the backshell in order to position it on the joint seat. With the proper heating tool, heat the first part on the backshell; once it has adhered then heat the part on the cable until it has completely shrunk. At the end of this operation put the group Connector-Cable in the correct position until the thermoshrinkable has completely cooled.

#### Multiple rubber-coated cables with thermo-shrinkable tubing

For this application follow the first 11 operating phases described for the RUBBER-COATED CABLES on pages 20-21.  
For the locking of the thermoshrinkable tubing follow phase 14 described above.

### Connectors Wiring Instructions

#### Multiple or single rubber-coated cables with protection tubing (UNI 4883)

This solution is used when a higher protection of the single or multiple cables is required using a linen-faced tubing according to norm UNI 4883 . Picture below shows a generic configuration of the used termination called BF.

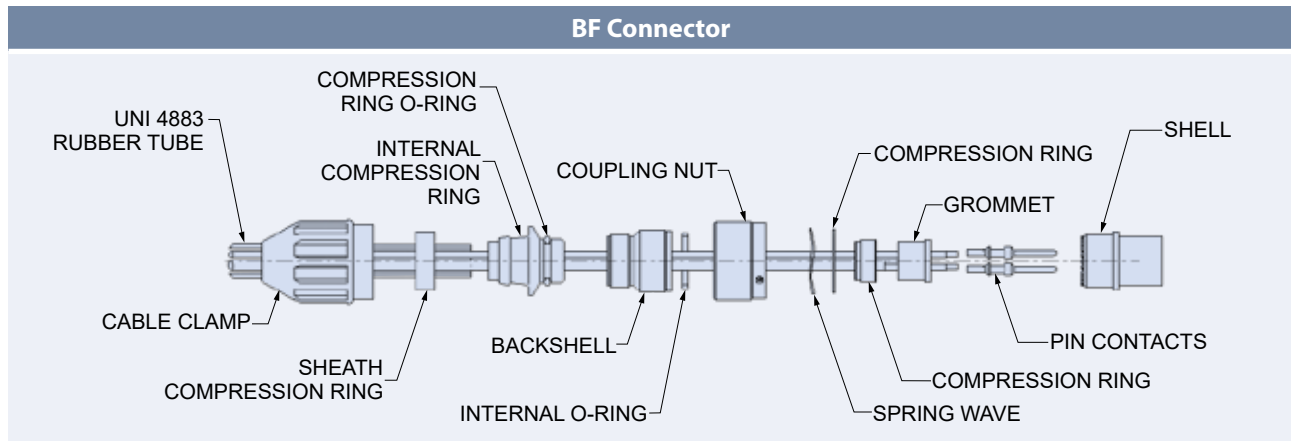

1. Pull off the cable or the cables from the linen-faced tubing with a sufficient length in order to easily operate during the wiring.
2. Make all the components of the connector slide on the cables, the cable clamp and the compression ring on the sheath according to the opposite sequence of the one of the assembly. (See picture above).
3. According to the kind of cable used, consult, for the wiring operation up to assembly of the backshell, the instructions of chapter MULTIPLE RUBBER-COATED CABLES on page 20, picture of receptacle or SINGLE CABLES on page 8, Table II.
4. Check the exact position of the compression ring O-Ring in its seat and insert the compression ring in the backshell until it stops.
5. Bring the linen-faced tubing on the conical part of the internal compression ring until it stops.
6. Forward the sheath compression ring and put it on the linen-faced tubing.
7. Screw the cable clamp on the backshell applying a locking force according to Table paying attention to use protected closing pliers type M. 120001 and M. 12002 to avoid to damage the external plating.

### Type BR connector

It is a kind of cable clamp aimed to fix the protection tubing type UNI 4883. It differs from the previous one (type BF) for its easiness of wiring, because the closing of the tubing is made by a metal clip. ( See picture below ).

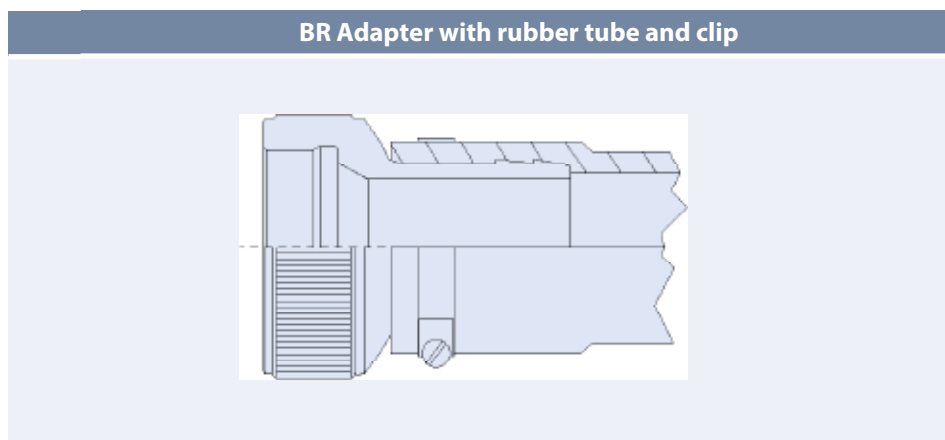

## Accessories and Tools

### TG38 Connector Wrench

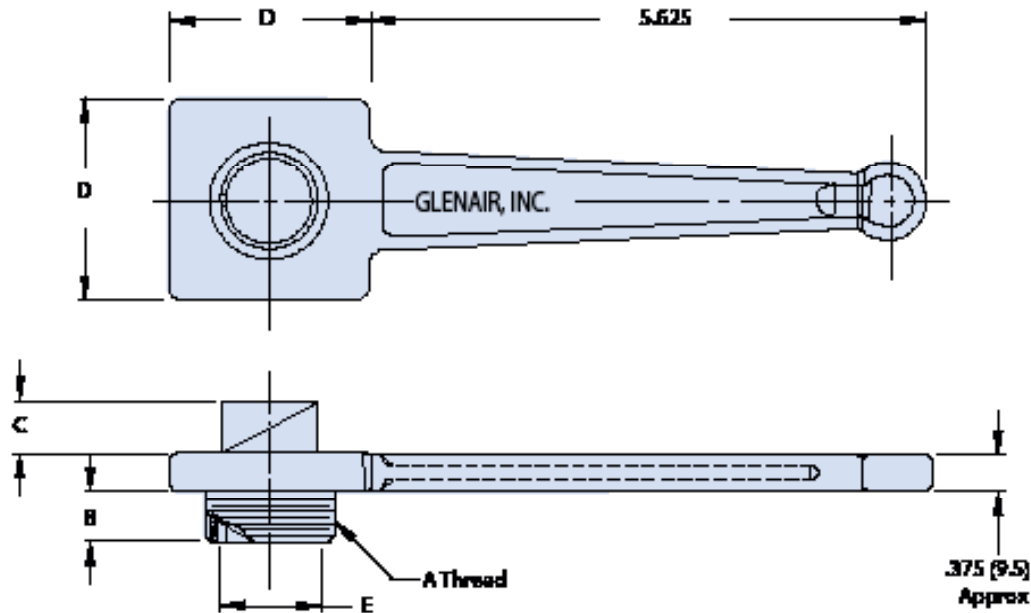

How to Order		
	<b>TG38</b>	<b>20</b>
Basic Number	<b>TG38</b>	
Dash Number	<b>20</b>	

Notes
1. Metric dimensions (mm) are indicated in parentheses.
2. Material: Aluminum alloy with electroless nickel finish.

Dash No.	Shell Size	A Thread Class 2A	B Approx.	C Approx.	D Dia. ±.062 (1.6)	E Dia. Ref.
8	8, 8S	1/2 -28 UNEF	.687 (17.4)	.718 (18.2)	1.250 (31.8)	.375 (9.5)
10	10S, 10SL	5/8 -24 UNEF	.687 (17.4)	.718 (18.2)	1.250 (31.8)	.450 (11.4)
12	12, 12S	3/4 -20 UNEF	.750 (19.1)	.921 (23.4)	1.250 (31.8)	.565 (14.4)
14	14, 14S	7/8 -20 UNEF	.750 (19.1)	.921 (23.4)	1.250 (31.8)	.685 (17.4)
16	16, 16S	1 -20 UNEF	.750 (19.1)	.921 (23.4)	2.000 (50.8)	.815 (20.7)
18	18	1 1/8 -18 UNEF	.750 (19.1)	.921 (23.4)	2.000 (50.8)	.940 (23.9)
20	20	1 1/4 -18 UNEF	.750 (19.1)	.921 (23.4)	2.000 (50.8)	1.060 (26.9)
22	22	1 3/8 -18 UNEF	.750 (19.1)	.921 (23.4)	2.000 (50.8)	1.185 (30.1)
24	24	1 1/2 -18 UNEF	.750 (19.1)	.921 (23.4)	2.000 (50.8)	1.317 (33.5)
28	28	1 3/4 -18 UNS	.750 (19.1)	.921 (23.4)	2.750 (69.9)	1.530 (38.9)
32	32	2 -18 UNS	.750 (19.1)	.921 (23.4)	2.750 (69.9)	1.780 (45.2)
36	36	2 1/4 -16 UN	.750 (19.1)	.921 (23.4)	2.750 (69.9)	1.995 (50.7)
40	40	2 1/2 -16 UN	.750 (19.1)	.921 (23.4)	2.750 (69.9)	2.245 (57.0)
44	44	2 3/4 -16 UN	.750 (19.1)	.921 (23.4)	2.750 (69.9)	2.500 (63.5)
48	48	3 -16 UN	.750 (19.1)	.921 (23.4)	2.750 (69.9)	2.750 (69.9)

# Wiring Instructions

for IT - FRIT (MIL-DTL-C-5015G) and ITB - ITS - FRITS (VG95234) Connectors



## Accessories and Tools

### TG70 Strap Wrench

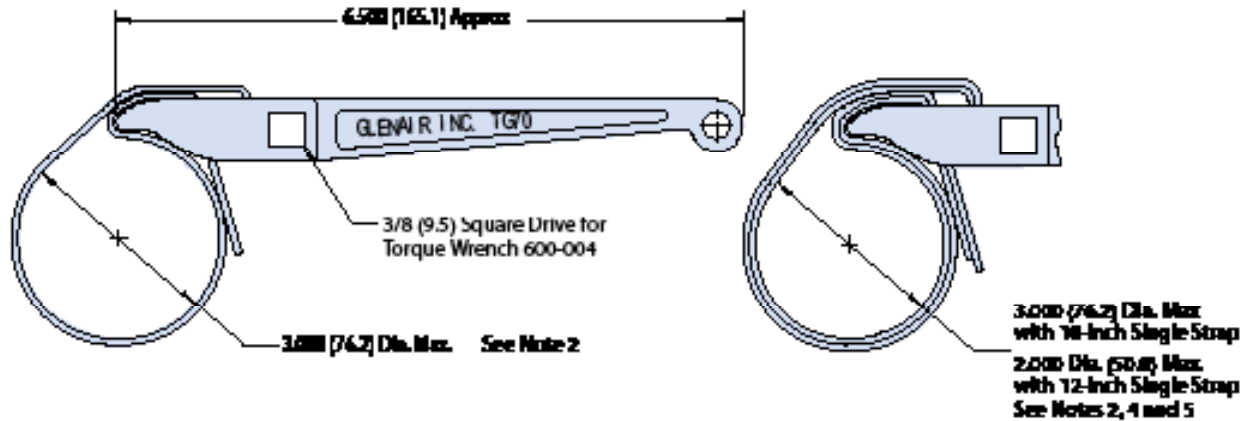

How to Order			
	TG70	-1	-18
Basic Number	TG70		
Torque Wrench	Omit for None		
Strap Length in Inches	Lengths available: 12, 18, 24 and 36-Inch Only Standard length is 12 Inches, Omit dash number for standard. See Notes 2 and 4.		

- | Notes   |
|---|
| 1. These wrenches are made of the following materials:<br>Wrench Handle - Aluminum Alloy/Nickel Plate.<br>Wedge - Stainless Steel/Passivated.<br>Strap - Impregnated Fabric. Straps are 1/2 inch (12.7) in width. |
| 2. Replacement straps are available. Specify part number G70515-xx for 12, 18, 24 or 36-inch strap. 24 and 36 inch for double wrap.   |
| 3. Metric dimensions (mm) are indicated in parentheses.   |
| 4. Double wrap as shown for heavy duty range.   |
| 5. Not recommended for composite coupling nuts (use 600-091 or 600-157).  |

VARIANCE CHART TG-70 Strap Wrench Used with Glenair Torque Wrenches				
Recommended Installation Torque				
Accessory Shell Size	Light/Medium Duty ± 5 Inch Pounds		Heavy Duty ± 5 Inch Pounds	
	TG70 Torque	Part Torque	TG70 Torque	Part Torque
08/09	28	35	45	60
10/11	28	35	70	80
12/13	30	40	75	110 [80]
14/15	30	40	75	120 [80]
16/17	30	40	75	120 [80]
18/19	30	40	75	120 [80]
20/21	75	80	95	140 [100]
22/23	75	80	120*	140
24/25	75	80	120*	140
28			135*	150
32			150*	150
36			150*	150

\* TG70 Not Recommended For Values of 120 Inch Lbs. or Greater.

- | Variance Chart Notes   |
|--|
| 1. Recommended installation torque is approximately 80% of MIL-C-85049 accessory thread strength values.   |
| 2. Heavy duty installation torque values may be difficult to attain with the TG70 Strap Wrench; the values shown in brackets [ ] are the maximum attainable with the TG70 Strap Wrench using a single wrap.                                  |
| 3. Glenair recommends using 600 series torque tools whenever possible. When torque loading exceeds 75 inch pounds, or to attain the heavy duty torque values shown, a double wrap strap provides suitable friction to achieve torque values. |
| 4. Glenair recommends that heavy duty torque values be directly read through the connector shell body with the use of 600-005 connectors holding tools.  |

# Wiring Instructions

for IT - FRIT (MIL-DTL-C-5015G) and ITB - ITS - FRITS (VG95234) Connectors



## Accessories and Tools

### 600-161 Digital Torque Wrench and 600-162 Bench Stand

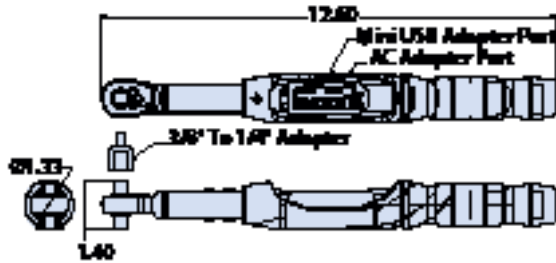

**Torque Wrench**  
600-161

### Digital Readout For Improved Accuracy

The Glenair Dual Drive Digital Torque Wrench (600-161) features a dual sided drive head for hand or bench mount use. Features an ergonomic handle with built-in digital readout display. Available torque units include: Ft-lb, Nm, Kg-Cm, or In-lb. Peak and Track modes available. Data collection via supplied USB and software provides quality departments the ability to track and record individual torque values.

1. Use in conjunction with glenair connector and backshell tools
2. Torque range: 15-300 in/lbs; digital graduations 1/10 In/lb;
3. Accuracy: cw/ccw  $\pm 2\%$  of reading 10% to 100% of full scale
4. replacement battery: AA x 2
5. USB cable, datatracking software, AC adapter, and 3/8" to 1/4" drive adapter included
6. weight: 1.45 Lb, w/case 2.28 Lb



### Horizontal Bench Stand

Constructed from aluminum the bench mount (600-162) features five position tilt settings.

1. Use in conjunction with glenair 600-161 digital torque wrench
2. Material: aluminum, steel, bronze weight: 4.62 Lb

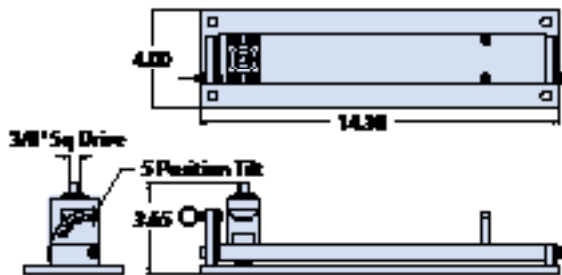

**Bench Stand**  
600-162



# Wiring Instructions

for IT - FRIT (MIL-DTL-C-5015G) and ITB - ITS - FRITS (VG95234) Connectors



## Accessories and Tools

### 600B005 Plug and Receptacle Holder

How to Order						
Product Series	600	B	005	-16	P	KIT
Connector Designator	B					
Basic Number	005					
Shell Size	-16		Omit for Kit			
Holder Type	P = Plug Holder R = Receptacle Holder					
KIT	KIT= Complete Kit					

Notes
1. Also mates with MIL-C-83723, Series II.
2. Metric dimensions (mm) are indicated in parentheses.
3. Material: Case hardened carbon steel with electroless nickel finish.
4. Receptacle and plug holder drives: 1/4" - Shell sizes 08, 10, 12; 3/8" - Shell sizes 14 and up.

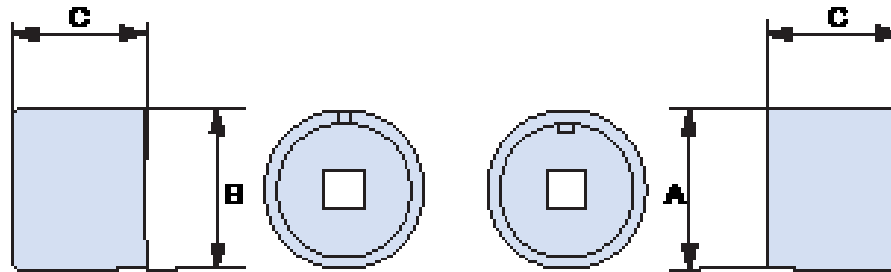

Table: Dimensions				
Shell Size	Max. Recommended Torque (Inch Pounds)	A Dia. Max.	B Dia. Max.	C Dim. Max.
08	60	.456 (11.6)	.365 (9.3)	1.25 (31.8)
10	80	.575 (14.6)	.440 (11.2)	1.25 (31.8)
12	110	.691 (17.6)	.555 (14.1)	1.25 (31.8)
14	120	.816 (20.7)	.675 (17.1)	1.25 (31.8)
16	120	.941 (23.9)	.805 (20.4)	1.25 (31.8)
18	120	1.060 (26.9)	.930 (23.6)	1.25 (31.8)
20	140	1.185 (30.1)	1.050 (26.7)	1.25 (31.8)
22	140	1.310 (33.3)	1.175 (29.8)	1.25 (31.8)
24	140	1.435 (36.4)	1.300 (33.0)	1.25 (31.8)
28	150	1.685 (42.8)	1.520 (38.6)	1.25 (31.8)
32	150	1.935 (49.1)	1.777 (45.0)	1.25 (31.8)
36	150	2.177 (55.3)	1.980 (50.3)	1.25 (31.8)

# Wiring Instructions

for IT - FRIT (MIL-DTL-C-5015G) and ITB - ITS - FRITS (VG95234) Connectors



## Accessories and Tools

### Torque Wrenches and Other Accessories

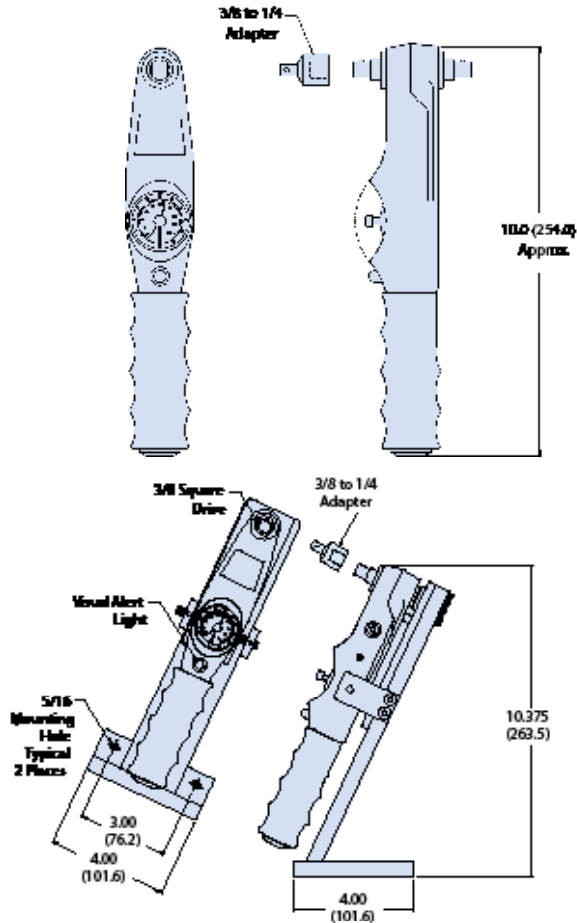

#### Hand-Held Torque Wrench

**600-076 High Torque**  
Adjustable to desired torque level of  
20 to 360 inch pounds

**600-004 Standard Torque**  
0 - 150 lb./in. (Not shown)

3/8" Drive Requires two Panasonic SR44W or equivalent batteries.

#### Bench-Mounted Torque Wrench

**600-077 High Torque**  
Adjustable to desired torque level of  
20 to 360 inch pounds

**600-007 Standard Torque**  
0 - 150 lb./in. (Not shown)

3/8" Drive Requires two Panasonic SR44W or equivalent batteries.

Wrenches		Other Accessories	
M.120001 Wrench for 60 - 120 mm		M.105004 Pedal	
M.120002 Wrench for 0 - 60 mm		M.105005 Support for pneumatic crimping tool M.105003	
		M.105006 Gauge	

### Contacts and Assembly Tools

#### Crimp contacts cross reference

Crimp Contacts Cross Reference							
P/N Veam	P/N Glenair	Size	Type	P/N Veam	P/N Glenair	Size	Type
46740 P	10-40579	18	-	46740 S	10-40588	18	C.E
27911	10-40553	16S	-	27961	10-40552	16S	L
27911-12	10-40553-12	16S	-	-	10-40552	16S	C.E
27911-13	10-40553-13	16S	-	27961-12	10-40552-12	16S	L
27911-15	10-40553-15	16S	-	27961-13	10-40552-13	16S	L
27911-20	10-40553-20	16S	-	27961-15	10-40552-15	16S	L
27911-26	10-40553-26	16S	-	27961-20	10-40552-20	16S	L
27913	10-40557	16	-	27961-26	10-40552-26	16S	L
27913-08	10-40557-08	16	-	27963	10-40556	16	L
27913-12	10-40557-12	16	-	-	10-40556 RES	16	R
27913-13	10-40557-13	16	-	-	10-40556 TU	16	C.E
27913-15	10-40557-15	16	-	-	10-40556-22 TU	16	C.E
27913-20	10-40557-20	16	-	27963-08	10-40556-08	16	L
27913-26	10-40557-26	16	-	27963-12	10-40556-12	16	L
27913-32	10-40557-32	16	-	27963-13	10-40556-13	16	L
27914-12	10-40561-12	12	-	27963-15	10-40556-15	16	L
27914-15	10-40561-15	12	-	27963-20	10-40556-20	16	L
27914-18	10-40561-20	12	-	27963-26	10-40556-26	16	L
27914-22	10-40561-22	12	-	27963-32	10-40556-32	16	L
27914-26	10-40561	12	-	27964-26	10-40560	12	L
27914-30	10-40561-30	12	-	-	10-40560 TU	12	C.E
27914-30M	10-40561-30M	12	-	27964-12	10-40560-12	12	L
27914-38	10-4561-38	12	-	27964-15	10-40560-15	12	L
27915	10-40792	8	-	27964-18	10-40560-20	12	L
27915-15	10-40792-15	8	-	27964-22	10-40560-22	12	L
27915-18	10-40792-18	8	-	27964-30	10-40560-30	12	L
27915-30	10-40792-30	8	-	27964-30M	10-40560-30M	12	L
27915-50	10-40792-50	8	-	27964-38	10-40560-38	12	L
27915-58	10-40792-58	8	-	-	10-40793	8	T
27916	10-113474-4P	4	-	27935	10-40793-1	8	C.E
27916-22	10-113474-4P-22	4	-	27935-15	10-40793-1-15	8	C.E
27916-26	10-113474-4P-26	4	-	27935-18	10-40793-1-18	8	C.E
27916-30	10-113474-4P-30	4	-	27935-30	10-40793-1-30	8	C.E
27916-50	10-113474-4P-50	4	-	27935-50	10-40793-1-50	8	C.E
27916-62	10-113474-4P-62	4	-	27935-58	10-40793-1-58	8	C.E
27916-78	10-113474-4P-25	4	-	-	10-40793-50	8	T
27916-90	10-113474-4P-35	4	-	-	10-40793-M4	8	T
27917	10-113474-1P	0	-	-	10-113-474-4S	4	T
27917-45	10-113474-1P-45	0	-	27936	10-113474-4S-1	4	C.E
27917-50	10-113474-1P-50	0	-	27936-22	10-113474-4S-1-22	4	C.E
27917-78	10-113474-1P-25	0	-	27936-26	10-113474-4S-1-26	4	C.E
27917-90	10-113474-1P-35	0	-	27936-30	10-113474-4S-1-30	4	C.E
27917-107	10-113474-1P-107	0	-	27936-50	10-113474-4S-1-50	4	C.E
-	10-40579 RES	18	-	27936-62	10-113474-4S-1-62	4	C.E
-	-	-	-	27936-78	10-113474-4S-1-25	4	C.E
-	-	-	-	27936-90	10-113474-4S-1-90	4	C.E
-	-	-	-	-	10-113474-4S-25M	4	T
-	-	-	-	27937	10-113474-1S	0	C.E
-	-	-	-	27937-45	10-113474-1S-45	0	C.E
-	-	-	-	27937-50	10-113474-1S-50	0	C.E
-	-	-	-	27937-78	10-113474-1S-25	0	C.E
-	-	-	-	27937-90	10-113474-1S-35	0	C.E
-	-	-	-	27937-107	10-113474-1S-107	0	C.E

# Wiring Instructions

for IT - FRIT (MIL-DTL-C-5015G) and ITB - ITS - FRITS (VG95234) Connectors



## Contacts and Assembly Tools

### CC 700XX - Size 8 Coaxial Pin and Socket Contacts

#### Coaxial Pin Contact

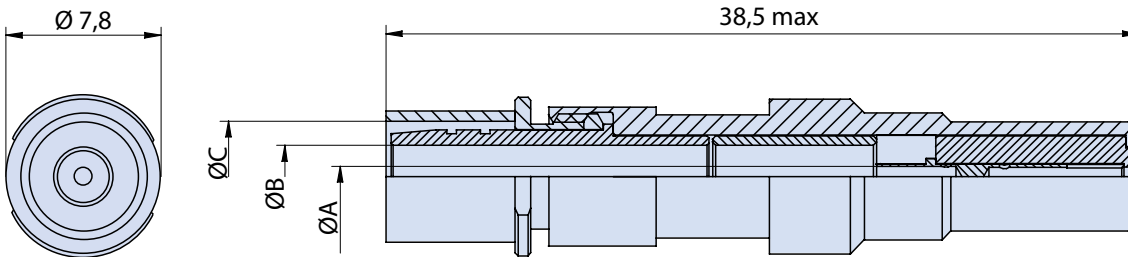

#### Coaxial Socket Contact

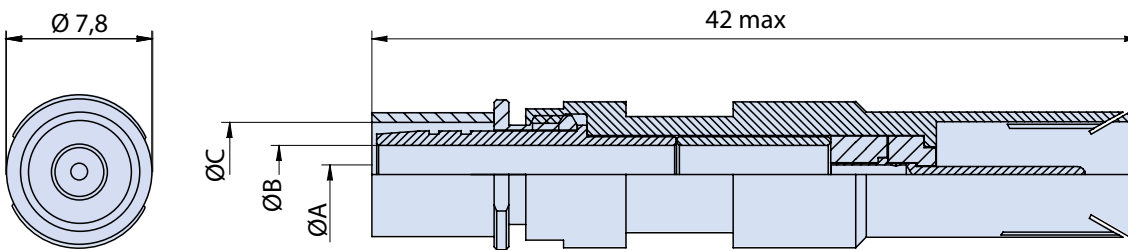

**Table: Coaxial Pin & Socket Contact Part Numbers, Cable Information and Dimensions**

Pin P/N	Socket P/N	Used with Cable	Ø A	Ø B	Ø C
CC 70038	CC 70040	RG 58	1.05	3.15	5.23
CC 70046	CC 70042	RG 59	0.75	3.90	5.60
CC 70054	CC 70052	RG 179	0.55	1.70	3.10
CC 70056	CC 70058	RG 174 / RG 316	0.75	1.70	3.10
CC 70060	CC 70062	RG 142	1.05	3.15	5.60
CC 70064	CC 70066	RG 223	1.05	3.15	5.90

#### Coaxial Insertion and Extraction Tool - Size 8



**M.118260/C**

Insertion and Extraction Tool for COAX Contacts Size 8

# Wiring Instructions

for IT - FRIT (MIL-DTL-C-5015G) and ITB - ITS - FRITS (VG95234) Connectors



## Contacts and Assembly Tools

### CC 700XX - Coaxial Contacts Assembly

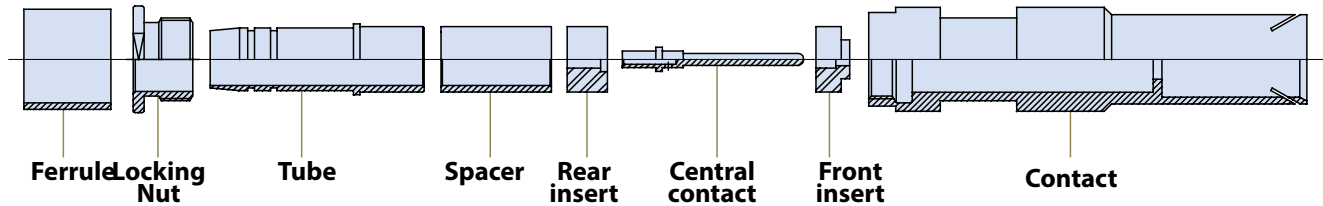

1 – Strip the cable according to the following dimensions

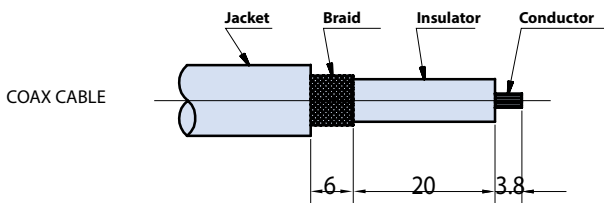

- 2 – Solder the central contact with the conductor of the coax cable after having pre-tinned the hole of the contact and the conductor, too
- 3 – Place the ferrule on the braid
- 4 – Place the locking nut on the tube and then this one on the insulator, then insert the tube under the braid
- 5 – Crimp the ferrule on the braid using the follow tools:  
 Crimping tool: M22520 / 5-01  
 Die assy for RG58: M22520 / 5-05 A  
 Die assy for RG59: M22520 / 5-45 B  
 Die assy for RG142: M22520 / 5-45 B  
 Die assy for RG174: M22520 / 5-08 A  
 Die assy for RG179: M22520 / 5-08 A  
 Die assy for RG223: M22520 / 5-45 A

Note: the nut has to remain free to rotate

- 6 – Withdraw the spacer on the insulator till it stops against the tube
- 7 – Place the rear insert on the central contact by the cut on the side

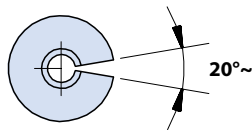

- 8 – Place the front insert on the central contact and insert everything inside the contact lightly pressing the rear insert; then screw the nut and the contact together.

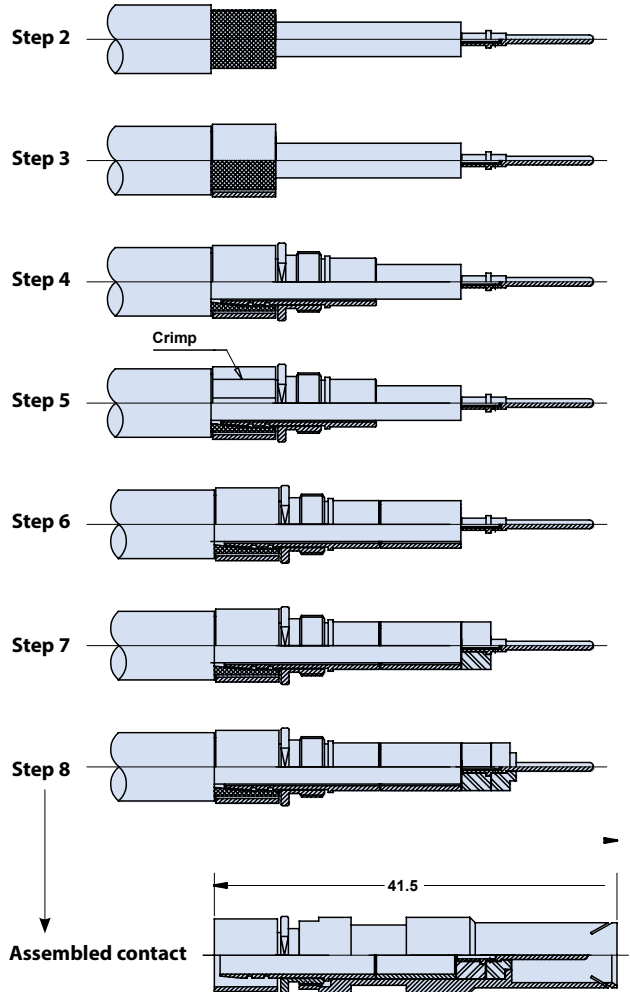

### Contacts and Assembly Tools

#### Insertion and Removal Tools for Pin Crimp Contacts

Insertion and Removal Tools Table					
Part Number	Contact Size	Wire Size		Insertion Tool	Removal Tool
		mm <sup>2</sup>	AWG	Glenair P/N	Glenair P/N
10-375-20	20	0,15-0,6	26÷20	M.117346	M.118251
10-40579	18	0,15÷0,6	26÷20	M.117346	M.118249
10-40553	16S	1÷1,5	18÷16	M.117083	M.118250
10-40553-12	16S	0,6	20	M.117083	M.118250
10-40553-13	16S	0,15÷0,6	26÷20	M.117346	M.118250
10-40553-15	16S	0,75-1,0	18	M.117083	M.118250
10-40553-20	16S	1-2	14	M.117083	M.118250
10-40553-26	16S	2,5-3,0	12	M.117082	M.118250
10-40557	16	1÷1,5	18÷16	M.117083	M.118250
10-40557L	16	1÷1,5	18÷16	M.117083	M.118250
10-40557-08	16	0,15÷0,2	26÷24	M.117346	M.118250
10-40557-12	16	0,6	20	M.117083	M.118250
10-40557-13	16	0,15÷0,6	26÷20	M.117346	M.118250
10-40557-15	16	0,75-1,0	18	M.117083	M.118250
10-40557-20	16	1-2	14	M.117083	M.118250
10-40557-22	16	2,5	/	M.117083	M.118250
10-40557-22L	16	2,5	/	M.117083	M.118250
10-40557-26	16	2,5-3,0	12	M.117083	M.118250
10-40557-32	16	/	32÷28	M.117083	M.118250
10-40561	12	2,5-3,0	12	M.117082	M.118250
10-40561-12	12	0,6	20	M.117083	M.118250
10-40561-15	12	0,75-1,0	18	M.117083	M.118250
10-40561-177	12	1,5	18-16	M.117082	M.118250
10-40561-20	12	2	14	M.117082	M.118250
10-40561-22	12	2,5	/	M.117082	M.118250
10-40561-30	12	4-5	/	M.117082	M.118250
10-40561-30M	12	4	/	M.117082	M.118250
10-40561-38	12	6	10	M.117082	M.118250

Please consult our sales department for other contact options or crimp tooling details.



### Contacts and Assembly Tools

#### Insertion and Removal Tools for Pin Crimp Contacts

Insertion and Removal Tools Table					
Part Number	Contact Size	Wire Size		Insertion Tool	Removal Tool
		mm <sup>2</sup>	AWG	Glenair P/N	Glenair P/N
10-40792	8	9	8	M.117344	M.118260
10-40792-15	8	0,75-1,0	18	M.117082	M.118260
10-40792-18	8	1÷2	18÷14	M.117082	M.118260
10-40792-20	8	2	14	M.117082	M.118260
10-40792-26	8	2,5-3,0	12	M.117082	M.118260
10-40792-30	8	4-5	/	M.117082	M.118260
10-40792-38	8	6	10	M.117344	M.118260
10-40792-50	8	10	/	M.117344	M.118260
10-40792-58	8	13,2	6	M.117344	M.118260
10-113474-4P	4	25	4	M.117347	M.118270
10-113474-4P-22	4	2,5	/	M.117082	M.118270
10-113474-4P-26	4	2,5-3,0	12	M.117082	M.118270
10-113474-4P-30	4	4-5	/	M.117082	M.118270
10-113474-4P-38	4	6	10	M.117344	M.118270
10-113474-4P-50	4	10	/	M.117344	M.118270
10-113474-4P-58	4	13,2	6	M.117344	M.118270
10-113474-4P-62	4	16	/	M.117347	M.118270
10-113474-1P	0	50-60	0	M.117348	M.118280
10-113474-1P-107	0	50	/	M.117348	M.118280
10-113474-1P-72	0	22-25	4	M.117347	M.118280
10-113474-1P-35	0	35	/	M.117348	M.118280
10-113474-1P-45	0	9	8	M.117344	M.118280
10-113474-1P-50	0	10	/	M.117344	M.118280
10-113474-1P-58	0	13,2	6	M.117344	M.118280
10-113474-1P-62	0	16	/	M.117347	M.118280
10-113474-0P	4/0	107	4/0	/	/
10-113474-0P-78	4/0	25	/	/	/
10-113474-0P-107	4/0	50	/	/	/
10-113474-0P-144	4/0	70	/	/	/

Please consult our sales department for other contact options or crimp tooling details.

#### Insertion and Removal Tools



Insertion Tool



Removal Tool

### Contacts and Assembly Tools

#### Insertion and Removal Tools for Socket Crimp Contacts

Insertion and Removal Tools Table						
Part Number	Contact Size	Wire Size		Insertion Tool	Removal Tool	Guide Pin
		mm <sup>2</sup>	AWG	Glenair P/N	Glenair P/N	
10-40520LC	20	0,15-0,6	26-20	M.117346	M.118251	M.125007
10-40588	18	0,15-0,6	26-20	M.117346	M.118249	M.125000
10-40552	16S	1-1,5	18-16	M.117083	M.118250	M.125001
10-40552-12	16S	0,6	20	M.117083	M.118250	M.125001
10-40552-13	16S	0,15-0,6	26-20	M.117346	M.118250	M.125001
10-40552-15	16S	0,75-1	18	M.117083	M.118250	M.125001
10-40552-20	16S	1-2	14	M.117083	M.118250	M.125001
10-40552-26	16S	2,5-3,0	12	M.117082	M.118250	M.125001
10-40556	16	1-1,5	18-16	M.117083	M.118250	M.125001
10-40556-08	16	0,15-0,2	26-24	M.117346	M.118250	M.125001
10-40556-12	16	0,6	20	M.117083	M.118250	M.125001
10-40556-13	16	0,15-0,6	26-20	M.117346	M.118250	M.125001
10-40556-15	16	0,75-1	18	M.117083	M.118250	M.125001
10-40556-20	16	1-2	14	M.117083	M.118250	M.125001
10-40556-22	16	2,5	/	M.117083	M.118250	M.125001
10-40556-26	16	2,5-3,0	12	M.117082	M.118250	M.125001
10-40556-32	16	/	32-28	M.117083	M.118250	M.125001
10-40560	12	2,5-3,0	12	M.117082	M.118250	M.125002
10-40560-12	12	0,6	20	M.117083	M.118250	M.125002
10-40560-15	12	0,75-1	18	M.117083	M.118250	M.125002
10-40560-177	12	1,5	18-16	M.117082	M.118250	M.125002
10-40560-20	12	2	14	M.117082	M.118250	M.125002
10-40560-22	12	2,5	/	M.117082	M.118250	M.125002
10-40560-30	12	4-5	/	M.117082	M.118250	M.125002
10-40560-30M	12	4	/	M.117082	M.118250	M.125002
10-40560-38	12	6	10	M.117082	M.118250	M.125002

Please consult our sales department for other contact options or crimp tooling details.



### Contacts and Assembly Tools

#### Insertion and Removal Tools for Socket Crimp Contacts

Insertion and Removal Tools Table						
Part Number	Contact Size	Wire Size		Insertion Tool	Removal Tool	Guide Pin
		mm <sup>2</sup>	AWG	Glenair P/N	Glenair P/N	
10-40793-1	8	9	8	M.117344	M.118260	M.125003
10-40793-1-15	8	0,75-1	18	M.117082	M.118260	M.125003
10-40793-1-18	8	1-2	18-14	M.117082	M.118260	M.125003
10-40793-1-20	8	2	14	M.117082	M.118260	M.125003
10-40793-1-26	8	2,5-3,0	12	M.117082	M.118260	M.125003
10-40793-1-30	8	4-5	/	M.117082	M.118260	M.125003
10-40793-1-38	8	6	10	M.117344	M.118260	M.125003
10-40793-1-50	8	10	/	M.117344	M.118260	M.125003
10-40793-1-58	8	13,2	6	M.117344	M.118260	/
10-113474-4S-1	4	22-25	4	M.117347	M.118270	/
10-113474-4S-1-22	4	2,5	/	M.117082	M.118270	/
10-113474-4S-1-26	4	2,5	12	M.117082	M.118270	/
10-113474-4S-1-30	4	4-5	/	M.117082	M.118270	/
10-113474-4S-1-38	4	6	10	M.117344	M.118270	/
10-113474-4S-1-50	4	10	/	M.117344	M.118270	/
10-113474-4S-1-58	4	13,2	6	M.117344	M.118270	/
10-113474-4S-1-62	4	16	/	M.117347	M.118270	/
10-113474-1S	0	50-60	0	M.117348	M.118280	/
10-113474-1S-107	0	50	/	M.117348	M.118280	/
10-113474-1S-72	0	22-25	4	M.117347	M.118280	/
10-113474-1S-35	0	35	/	M.117348	M.118280	/
10-113474-1S-45	0	9	8	M.117344	M.118280	/
10-113474-1S-50	0	10	/	M.117344	M.118280	/
10-113474-1S-58	0	13,2	6	M.117344	M.118280	/
10-113474-1S-62	0	16	/	M.117347	M.118280	/
10-113474-0S	4/0	107	4/0	/	/	/
10-113474-0S-78	4/0	22-25	4	/	/	/
10-113474-0S-107	4/0	50	/	/	/	/
10-113474-0S-144	4/0	70	/	/	/	/

Please consult our sales department for other contact options or crimp tooling details.

#### Insertion and Removal Tools



Insertion Tool



Removal Tool



Guide Pin

# Wiring Instructions

for IT - FRIT (MIL-DTL-C-5015G) and ITB - ITS - FRITS (VG95234) Connectors



## Contacts and Assembly Tools

### Manual and Pneumatic Tools for Pin Crimp Contacts

Manual and Pneumatic Tools Table							
Part Number	Contact Size	Wire Size		Manual Crimp Tool		Pneumatic Tool Type "A"	
		mm <sup>2</sup>	AWG	Manual Tool	Turret	Pneumatic Tool	Turret
10-375-20	20	0,15-0,6	26÷20	M.105001	M.105026	M.105003	M.105026
10-40579	18	0,15÷0,6	26÷20	M.105001	M.105025	M.105003	M.105025
10-40553	16S	1÷1,5	18÷16	M.105007	M.105009	M.105002	M.105009
10-40553-12	16S	0,6	20	M.105007	M.105009	M.105002	M.105009
10-40553-13	16S	0,15÷0,6	26÷20	M.105001	M.105009	M.105003	M.105009
10-40553-15	16S	0,75-1,0	18	M.105007	M.105009	M.105002	M.105009
10-40553-20	16S	1-2	14	M.105007	M.105009	M.105002	M.105009
10-40553-26	16S	2,5-3,0	12	M.105007	M.105009	M.105002	M.105009
10-40557	16	1÷1,5	18÷16	M.105007	M.105009	M.105002	M.105012
10-40557L	16	1÷1,5	18÷16	M.105007	M.105012	M.105002	M.105009
10-40557-08	16	0,15÷0,2	26÷24	M.105001	M.105009	M.105003	M.105009
10-40557-12	16	0,6	20	M.105007	M.105009	M.105003	M.105009
10-40557-13	16	0,15÷0,6	26÷20	M.105001	M.105009	M.105003	M.105009
10-40557-15	16	0,75-1,0	18	M.105007	M.105009	M.105002	M.105009
10-40557-20	16	1-2	14	M.105007	M.105009	M.105002	M.105009
10-40557-22	16	2,5	/	M.105007	M.105009	M.105002	M.105009
10-40557-22L	16	2,5	/	M.105007	M.105012	M.105002	M.105012
10-40557-26	16	2,5-3,0	12	M.105007	M.105009	M.105002	M.105009
10-40557-32	16	/	32÷28	M.105007	M.105009	M.105003	M.105009
10-40561	12	2,5-3,0	12	M.105007	M.105009	M.105002	M.105009
10-40561-12	12	0,6	20	M.105007	M.105009	M.105003	M.105009
10-40561-15	12	0,75-1,0	18	M.105007	M.105009	M.105002	M.105009
10-40561-177	12	1,5	18-16	M.105007	M.105009	M.105002	M.105009
10-40561-20	12	2	14	M.105007	M.105009	M.105002	M.105009
10-40561-22	12	2,5	/	M.105007	M.105009	M.105002	M.105009
10-40561-30	12	4-5	/	M.105007	M.105009	M.105002	M.105009
10-40561-30M	12	4	/	M.105007	M.105009	M.105002	M.105009
10-40561-38	12	6	10	M.105007	M.105009	M.105002	M.105009

Please consult our sales department for other contact options or crimp tooling details.

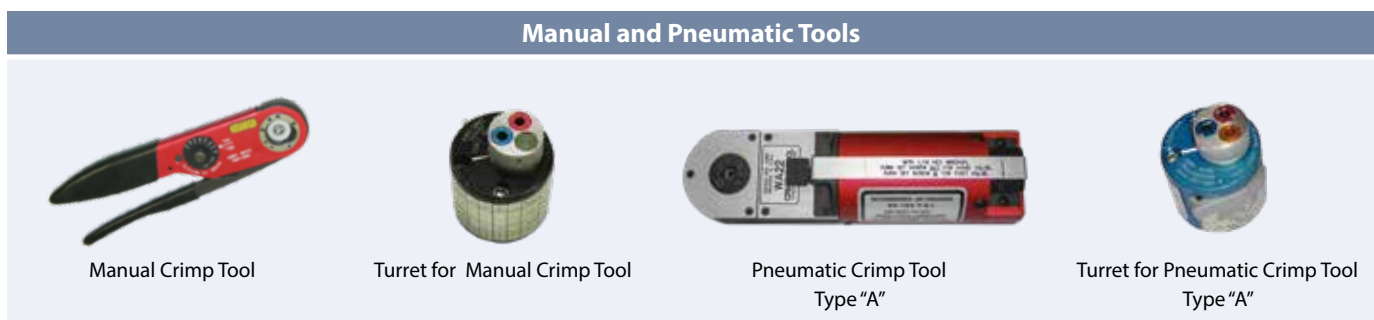

# Wiring Instructions

for IT - FRIT (MIL-DTL-C-5015G) and ITB - ITS - FRITS (VG95234) Connectors



## Contacts and Assembly Tools

### Manual and Pneumatic Tools for Pin Crimp Contacts

Manual and Pneumatic Tools Table										
Part Number	Contact Size	Wire Size		Manual Crimp Tool		Pneumatic Tool Type "B"			Oleodinamic Tool	
		mm <sup>2</sup>	AWG	Manual Tool	Turret	Pneumatic Tool	Die	Locator	Oleodinamic Tool	Die
10-40792	8	9	8	/	/	M.112000	M.112001	M.112309	M.112004	M.112005
10-40792-15	8	0,75-1,0	18	M.105028	M.104002	/	/	/	/	/
10-40792-18	8	1÷2	18÷14	M.105028	M.104002	/	/	/	/	/
10-40792-20	8	2	14	M.105028	M.104002	/	/	/	/	/
10-40792-26	8	2,5-3,0	12	M.105028	M.104002	/	/	/	/	/
10-40792-30	8	4-5	/	M.105028	M.104002	/	/	/	M.112004	M.112008
10-40792-38	8	6	10	/	/	M.112000	M.112001	M.112309-1	M.112004	M.112005
10-40792-50	8	10	/	/	/	M.112000	M.112001	M.112309-1	M.112004	M.112005
10-40792-58	8	13,2	6	/	/	M.112000	M.112001	M.112309-1	M.112004	M.112005
10-113474-4P	4	25	4	/	/	M.112000	M.112002	M.112311	M.112004	M.112006
10-113474-4P-22	4	2,5	/	/	/	/	/	/	M.112004	M.112009
10-113474-4P-26	4	2,5-3,0	12	/	/	/	/	/	M.112004	M.112009
10-113474-4P-30	4	4-5	/	/	/	/	/	/	M.112004	M.112008
10-113474-4P-38	4	6	10	/	/	M.112000	M.112001	M.112311	M.112004	M.112005
10-113474-4P-50	4	10	/	/	/	M.112000	M.112001	M.112311	M.112004	M.112005
10-113474-4P-58	4	13,2	6	/	/	M.112000	M.112001	M.112311	M.112004	M.112005
10-113474-4P-62	4	16	/	/	/	M.112000	M.112002	M.112311	M.112004	M.112006
10-113474-1P	0	50-60	0	/	/	M.112000	M.112003	M.112313	M.112004	M.112010
10-113474-1P-107	0	50	/	/	/	M.112000	M.112003	M.112313	M.112004	M.112010
10-113474-1P-72	0	22-25	4	/	/				M.112004	M.112006
10-113474-1P-35	0	35	/	/	/	/	/	/	M.112004	M.112007
10-113474-1P-45	0	9	8	/	/				M.112004	M.112005
10-113474-1P-50	0	10	/	/	/				M.112004	M.112005
10-113474-1P-58	0	13,2	6	/	/				M.112004	M.112005
10-113474-1P-62	0	16	/	/	/				M.112004	M.112006
10-113474-0P	4/0	107	4/0	/	/	/	/	/	M.105013	M.112012
10-113474-0P-78	4/0	25	/	/	/	/	/	/	M.112004	M.112006
10-113474-0P-107	4/0	50	/	/	/	/	/	/	M.112004	M.112010
10-113474-0P-144	4/0	70	/	/	/	/	/	/	M.105013	M.105053

Please consult our sales department for other contact options or crimp tooling details.

### Manual and Pneumatic Tools



Pneumatic Crimp Tool Type "B"



Die For Pneumatic Crimp Tool Type "B"



Locator for Pneumatic Crimp Tool Type "B"



Oleodinamic Crimp Tool



Die for Oleodinamic Crimp Tool

### Contacts and Assembly Tools

#### Manual and Pneumatic Tools for Socket Crimp Contacts

Manual and Pneumatic Tools Table							
Part Number	Contact Size	Wire Size		Manual Crimp Tool		Pneumatic Tool Type "A"	
		mm <sup>2</sup>	AWG	Manual Tool	Turret	Pneumatic Tool	Turret
10-40520LC	20	0,15-0,6	26-20	M.105001	M.105026	M.105003	M.105026
10-40588	18	0,15-0,6	26-20	M.105001	M.105025	M.105003	M.105025
10-40552	16S	1-1,5	18-16	M.105007	M.105009	M.105002	M.105009
10-40552-12	16S	0,6	20	M.105007	M.105009	M.105002	M.105009
10-40552-13	16S	0,15-0,6	26-20	M.105001	M.105009	M.105003	M.105009
10-40552-15	16S	0,75-1	18	M.105007	M.105009	M.105002	M.105009
10-40552-20	16S	1-2	14	M.105007	M.105009	M.105002	M.105009
10-40552-26	16S	2,5-3,0	12	M.105007	M.105009	M.105002	M.105009
10-40556	16	1-1,5	18-16	M.105007	M.105009	M.105002	M.105009
10-40556-08	16	0,15-0,2	26-24	M.105001	M.105009	M.105003	M.105009
10-40556-12	16	0,6	20	M.105007	M.105009	M.105003	M.105009
10-40556-13	16	0,15-0,6	26-20	M.105001	M.105009	M.105003	M.105009
10-40556-15	16	0,75-1	18	M.105007	M.105009	M.105002	M.105009
10-40556-20	16	1-2	14	M.105007	M.105009	M.105002	M.105009
10-40556-22	16	2,5	/	M.105007	M.105009	M.105002	M.105009
10-40556-26	16	2,5-3,0	12	M.105007	M.105009	M.105002	M.105009
10-40556-32	16	/	32-28	M.105007	M.105009	M.105003	M.105009
10-40560	12	2,5-3,0	12	M.105007	M.105009	M.105002	M.105009
10-40560-12	12	0,6	20	M.105007	M.105009	M.105003	M.105009
10-40560-15	12	0,75-1	18	M.105007	M.105009	M.105002	M.105009
10-40560-177	12	1,5	18-16	M.105007	M.105009	M.105002	M.105009
10-40560-20	12	2	14	M.105007	M.105009	M.105002	M.105009
10-40560-22	12	2,5	/	M.105007	M.105009	M.105002	M.105009
10-40560-30	12	4-5	/	M.105007	M.105009	M.105002	M.105009
10-40560-30M	12	4	/	M.105007	M.105009	M.105002	M.105009
10-40560-38	12	6	10	M.105007	M.105009	M.105002	M.105009

Please consult our sales department for other contact options or crimp tooling details.

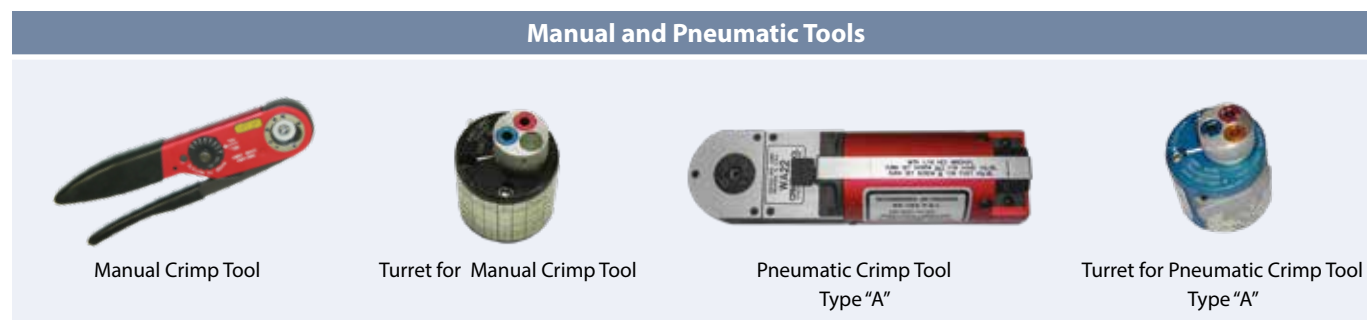

# Wiring Instructions

for IT - FRIT (MIL-DTL-C-5015G) and ITB - ITS - FRITS (VG95234) Connectors



## Contacts and Assembly Tools

### Manual and Pneumatic Tools for Socket Crimp Contacts

Manual and Pneumatic Tools Table										
Part Number	Contact Size	Wire Size		Manual Crimp Tool		Pneumatic Tool Type "B"			Oleodinamic Tool	
		mm <sup>2</sup>	AWG	Manual Tool	Turret	Pneumatic Tool	Die	Locator	Oleodinamic Tool	Die
10-40793-1	8	9	8	/	/	M.112000	M.112001	M.112309	M.112004	M.112005
10-40793-1-15	8	0,75-1	18	M.105028	M.104002	/	/	/	/	/
10-40793-1-18	8	1-2	18-14	M.105028	M.104002	/	/	/	/	/
10-40793-1-20	8	2	14	M.105028	M.104002	/	/	/	/	/
10-40793-1-26	8	2,5-3,0	12	M.105028	M.104002	/	/	/	/	/
10-40793-1-30	8	4-5	/	M.105028	M.104002	/	/	/	M.112004	M.112008
10-40793-1-38	8	6	10	/	/	M.112000	M.112001	M.112309	M.112004	M.112005
10-40793-1-50	8	10	/	/	/	M.112000	M.112001	M.112309	M.112004	M.112005
10-40793-1-58	8	13,2	6	/	/	M.112000	M.112001	M.112309	M.112004	M.112005
10-113474-4S-1	4	25	4	/	/	M.112000	M.112002	M.112311	M.112004	M.112006
10-113474-4S-1-22	4	2,5	/	/	/	/	/	/	M.112004	M.112009
10-113474-4S-1-26	4	2,5-3,0	12	/	/	/	/	/	M.112004	M.112009
10-113474-4S-1-30	4	4-5	/	/	/	/	/	/	M.112004	M.112008
10-113474-4S-1-38	4	6	10	/	/	M.112000	M.112001	M.112311	M.112004	M.112005
10-113474-4S-1-50	4	10	/	/	/	M.112000	M.112001	M.112311	M.112004	M.112005
10-113474-4S-1-58	4	13,2	6	/	/	M.112000	M.112001	M.112311	M.112004	M.112005
10-113474-4S-1-62	4	16	/	/	/	M.112000	M.112002	M.112311	M.112004	M.112006
10-113474-1S	0	50-60	0	/	/	M.112000	M.112003	M.112313	M.112004	M.112010
10-113474-1S-107	0	50	/	/	/	M.112000	M.112003	M.112313	M.112004	M.112010
10-113474-1S-72	0	22-25	4	/	/	M.112000	M.112002	M.112313	M.112004	M.112006
10-113474-1S-35	0	35	/	/	/	/	/	/	M.112004	M.112007
10-113474-1S-45	0	9	8	/	/				M.112004	M.112005
10-113474-1S-50	0	10	/	/	/				M.112004	M.112005
10-113474-1S-58	0	13,2	6	/	/				M.112004	M.112005
10-113474-1S-62	0	16	/	/	/				M.112004	M.112006
10-113474-0S	4/0	107	4/0	/	/	/	/	/	M.105013	M.112012
10-113474-0S-78	4/0	25	/	/	/	/	/	/	M.112004	M.112006
10-113474-0S-107	4/0	50	/	/	/	/	/	/	M.112004	M.112010
10-113474-0S-144	4/0	70	/	/	/	/	/	/	M.105013	M.105053

Please consult our sales department for other contact options or crimp tooling details.

### Manual and Pneumatic Tools



Pneumatic Crimp Tool Type "B"



Die For Pneumatic Crimp Tool Type "B"



Locator for Pneumatic Crimp Tool Type "B"



Oleodinamic Crimp Tool



Die for Oleodinamic Crimp Tool



Glenair®



## SERIES ITS & DERIVATIVES

**Circular industrial power and signal connectors for rugged applications— from mining equipment to military vehicles**



- Dozens of proven connector technologies for harsh application environments
- Hundreds of power and signal contact arrangements (crimp and solder)
- Threaded, reverse bayonet, and innovative latch-and-lock coupling technologies
- Flame-resistant, caustic substance-free material choices for RoHS and other compliance standards

### Circular Reverse-Bayonet and Threaded Coupling Connectors

**Series ITS** - Reverse-Bayonet Power and Signal  
**Series ITS-RG** - RadGrip™ Rubber Coupling Nut Circular  
**Series FRITS** - Flame-Resistant Insert for Rail Applications  
**Series IT** - Threaded Coupling Power and Signal  
**Series ITH** - Rigid Insert / Mechanical Contact Retention  
**Series ITK** - High-Temperature Ceramic  
**Series ITZ** - Triple-Start Thread Power and Signal  
**Series IFO** - Reverse-Bayonet Fiber Optic  
**Series IGE** - High Current, Low Voltage Single Pole  
**Series 901** - High Current Medium Voltage Circular  
**Series 500** - Reverse-Bayonet Single-Pole High Voltage  
**Series IPT** - Standard Bayonet Power and Signal  
**Series IPT-SE** - Standard Bayonet Crimp Contact



Series IT, ITS and derivative connector families are available with three plug coupling nut designs: Standard, Arctic, and rubber-covered RadGrip™

# INDUSTRY STANDARD AND GLENAIR INNOVATIONS Industrial/Rail Power and Signal Connectors



## CIRCULAR INDUSTRIAL/RAIL POWER AND SIGNAL CONNECTORS: 5015 TYPE DERIVATIVES



Series ITS  
Reverse-Bayonet



Series ITH  
Rigid Insert



Series IT  
Threaded Coupling

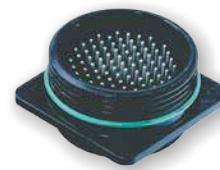

Series ITZ  
Triple-Start Coupling



Series ITK  
High-Temperature Ceramic  
Insert



Seacrow  
Marine Bronze



Series 901  
Multi-Pin High Voltage



Series 500  
Single-Pole High Voltage



Series IGE  
Single-Pole High Power



Series ITS Bayonet  
with Wing Locks

## HIGH-SPEED / RUGGEDIZED CONNECTORS FOR INDUSTRIAL AND RAIL APPLICATIONS



SuperSeal™  
with RJ45 Ethernet



Series CX  
High-Speed Coaxial



Octobyte™  
Ethernet Contact



Series IFO  
High-Speed Fiber Optic

## SERIES ITS-RG RADGRIP™ REINFORCED RUBBER COUPLING NUT CONNECTORS



ITS-RG  
(Basic Black)



ITS-RG  
(Semper Tan)



ITS-RG  
(Fiber Optic Blue)



ITS-RG  
(Safety Red)



# Our Commit

## Management System Certifications for Quality



- **ISO 9001:** this is a common standard Certification , its widespread and well known. It covers all the activities of Glenair Italy.
- **IRIS:** this system is based on ISO 9001 with specific requirements on railway sector. It covers all production of Glenair Italy in relation to the Mass Transit market (connectors, cabling, GLM products).
- **EN 9100:** this system is based on ISO 9001 with specific requirements on Aviation, Space and Defence industries. It covers all design, production of Glenair Italy relating to production in these three sectors.
- **EN 9120:** this system is based on ISO 9001 with specific requirements on Aviation, Space and Defence industries. It covers all distribution of Glenair in relation to these three sectors.



# ment to Quality

## Product Certifications



- **VG 95234, VG 95328, VG 95351, VG 96929, VG 96934:** these are certifications for five product families. They certify that our family of products guarantee the minimum performance requirements laid down by the relevant standard. They are issued by an institution of the German Ministry of Defense (BAAINBw) and are recognized by military entities in all NATO countries.
- **UL:** Upon request, some connectors from the ITS Series can be marked as a "UL Recognized Component."
- **ATEX/IECEX:** Glenair is a qualified manufacturer of connectors for potential explosive zone use according to IEC/EN 60079.



## Test Lab Certification



- **ISO / IEC 17025:** this is a Test Lab certification from an independent laboratory. It certifies that our Test Lab is able to run to a series of professional certificate-level tests, listed in the same certificate, without having conflicts of interest with other activities in Glenair Italy establishment.





*Out of This World*

# INTERCONNECT SOLUTIONS

## Glenair, Inc.

1211 Air Way • Glendale, California • 91201-2497

Telephone: 818-247-6000 • Fax: 818-500-9912 • sales@glenair.com

[www.glenair.com](http://www.glenair.com)

---

### Glenair Power Products Group

860 N. Main Street Extension  
Wallingford, CT  
06492

Telephone:  
203-741-1115  
Facsimile:  
203-741-0053  
sales@glenair.com

---

### Glenair UK Ltd

40 Lower Oakham Way  
Oakham Business Park  
P.O. Box 37, Mansfield  
Notts, NG18 5BY England

Telephone:  
+44-1623-638100  
Facsimile:  
+44-1623-638111  
sales@glenair.co.uk

---

### Glenair Microway Systems

7000 North Lawndale Avenue  
Lincolnwood, IL  
60712

Telephone:  
847-679-8833  
Facsimile:  
847-679-8849

---

### Glenair Nordic AB

Gustav III : S Boulevard 46  
SE-169 27 Solna  
Sweden

Telephone:  
+46-8-50550000  
sales@glenair.se

---

### Glenair Electric GmbH

Schaberweg 28  
61348 Bad Homburg  
Germany

Telephone:  
06172 / 68 16 0  
Facsimile:  
06172 / 68 16 90  
info@glenair.de

---

### Glenair Iberica

C/ La Vega, 16  
45612 Velada  
Spain

Telephone:  
+34-925-89-29-88  
Facsimile:  
+34-925-89-29-87  
sales@glenair.es

---

### Glenair Italia S.p.A.

Via Del Lavoro, 7  
40057 Quarto Inferiore –  
Granarolo dell'Emilia  
Bologna, Italy

Telephone:  
+39-051-782811  
Facsimile:  
+39-051-782259  
info@glenair.it

---

### Glenair France SARL

7, Avenue Parmentier  
Immeuble Central Parc #2  
31200 Toulouse  
France

Telephone:  
+33-5-34-40-97-40  
Facsimile:  
+33-5-61-47-86-10  
sales@glenair.fr

---

### Glenair Korea

B-1304 Gunpo IT Valley  
148 Gosan-Ro, Gunpo-Si  
Kyunggi-Do, Korea  
435-733

Telephone:  
+82-31-8068-1090  
Facsimile:  
+82-31-8068-1092  
sales@glenair.kr