

182 - 001

S

W

Product Series

Basic Number

S - Socket
P - Pin

W - Wet Polish Tool Supplied
(Omit for Dry Polish)

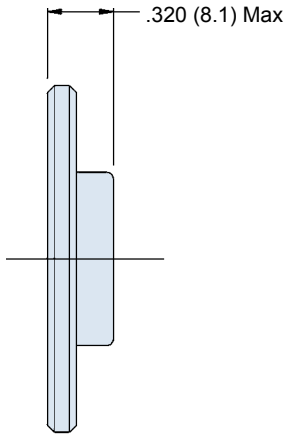

P

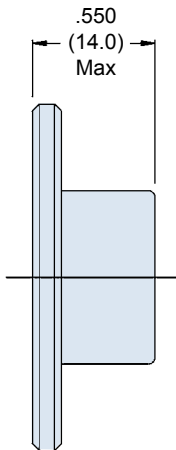
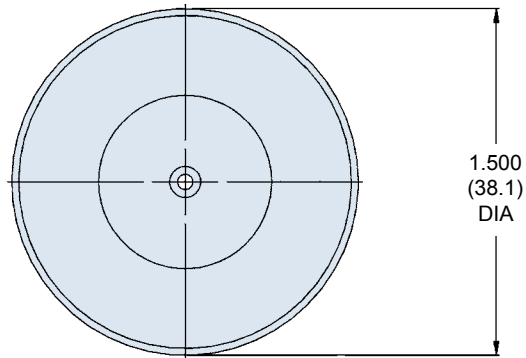

S

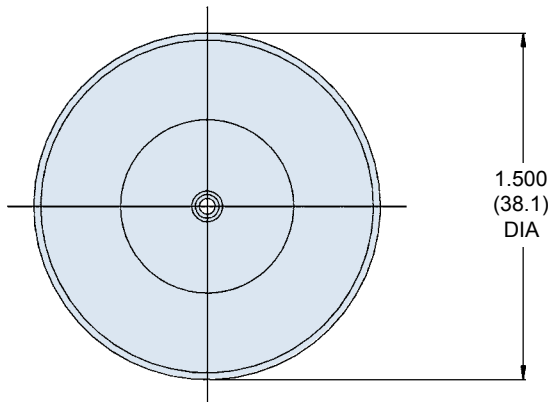

APPLICATION NOTES

1. Metric dimensions (mm) are indicated in parentheses.
2. Assembly packaged in plastic bag and tag identified with manufacturer's name and part number.
3. Material/Finish: Stainless steel/passivated.