

The Advanced D-Sub Connector for Reliable Performance in Hostile Environments

Product Features

- Environmental, crimp removable rectangular connector
- Advanced temperature, vibration and EMC/electrical performance
- M24308/D-Sub intermateable
- Fits panel and PCB footprint of M24308/D-Sub products
- Available in all 11 "standard" insert arrangements
- Standard Density (#20) and High Density (#22D)
- EMI spring
- High temperature thermoset epoxy insulators
- Watertight sealing
- Rugged machined one-piece shell
- Optional guide pins for blind mating



Available configurations

- Crimp termination for attaching wire or cable: Standard cable, rear panel mount and float mount
- Printed circuit board termination for rear panel mounting: Straight and right angle
- Free-standing printed circuit board termination: Straight and right angle

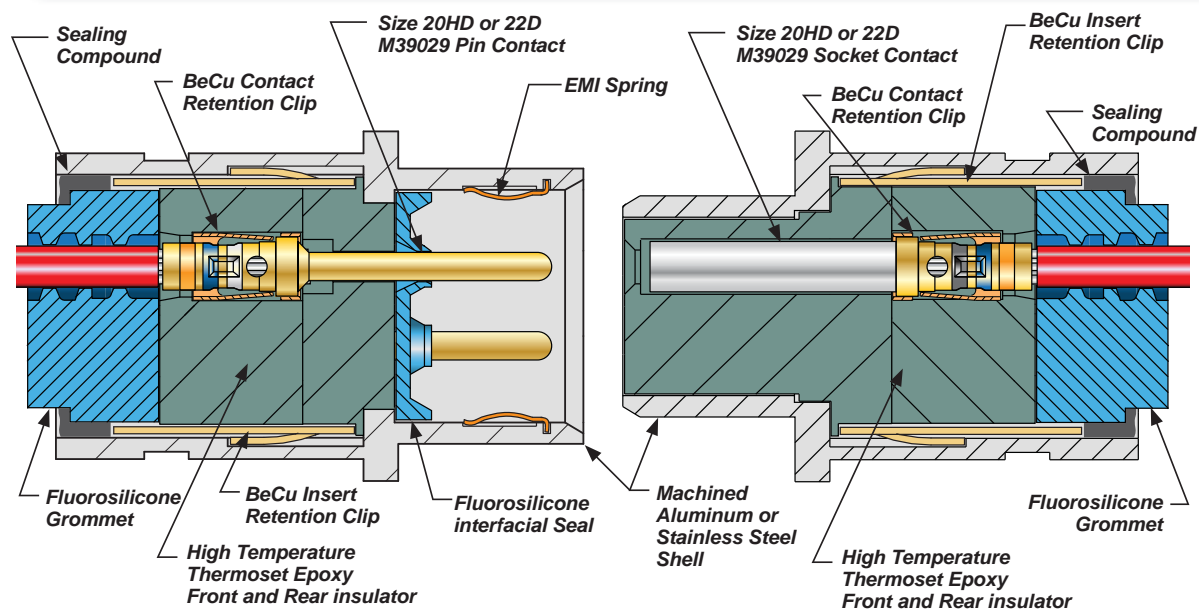

Dimensions in inches (millimeters) and are subject to change without notice.