

Series 803 Mighty Mouse 1/4 Turn Bayonet Coupling PCB Connector Ordering Information

803-005, 803-015



Series 803



Series 803 Printed Circuit Board Receptacle

Printed Circuit Board/Solder Cup Receptacles feature low profile shells for minimum protrusion inside enclosures and integral standoffs for board washout. Contacts are non-removable.

Water Immersion, Unmated

Specify **803-005** connectors for applications where open face water immersion is not a requirement. For MIL-STD-810 Method 512G immersion requirements, specify **803-015** watertight connectors. These 803-015 connectors are specially sealed ("MOD-518") and are 100% tested to maintain a helium leak rate of 1×10^{-4} cc/second at one atmosphere pressure differential from -40C to +70C. **NOTE: mated connectors are not submersible.**

HOW TO ORDER SERIES 803 PRINTED CIRCUIT BOARD RECEPTACLES

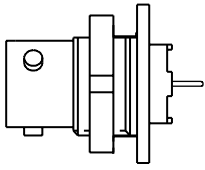
Sample Part Number					
803-005	-07	ZN	6-7	S	N
Series	Shell Style	Shell Material / Finish	Shell Size- Insert Arrangement	Contact Type	Shell Key Position
<p>803-005 Receptacle for Solder Cup or PCB Termination, with Standard Epoxy Potting</p>  <p>- 02 Flange Mount</p>	<p>803-015 Receptacle for Solder Cup or PCB Termination, With Resilient Silicone Potting For Watertight Seal from -40° to +70°C (15 PSI Pressure Differential)</p>  <p>- 07 Jam Nut</p>	<p>C Aluminum / Black Anodize (Non-Conductive) RoHS Compliant</p> <p>M Aluminum / Electroless Nickel RoHS Compliant</p> <p>NF Aluminum / Cadmium with Olive Drab Chromate</p> <p>ZN Aluminum / Zinc-Nickel with Olive Drab Chromate</p> <p>ZNU Aluminum / Zinc-Nickel with Black Chromate</p> <p>MT Aluminum / Nickel-PTFE RoHS Compliant</p> <p>Z1 Stainless Steel / Passivated RoHS Compliant</p>	<p>SEE CONTACT ARRANGEMENTS PAGE F-2</p>	<p>P Pin, PC Tail</p> <p>S Socket, PC Tail</p> <p>E Pin, Solder Cup</p> <p>F Socket, Solder Cup</p>	<p>N Normal Alternative Key Positions:</p> <p>X</p> <p>Y</p> <p>Z</p>

F

Dimensions in inches (millimeters) and are subject to change without notice.

© 2010 Glenair, Inc.

CAGE Code 06324

Printed in U.S.A.

GLENAIR, INC. • 1211 AIR WAY • GLENDALE, CA 91201-2497 • 818-247-6000 • FAX 818-500-9912

www.glenair.com

F-11

E-Mail: sales@glenair.com

01-JANUARY-2010

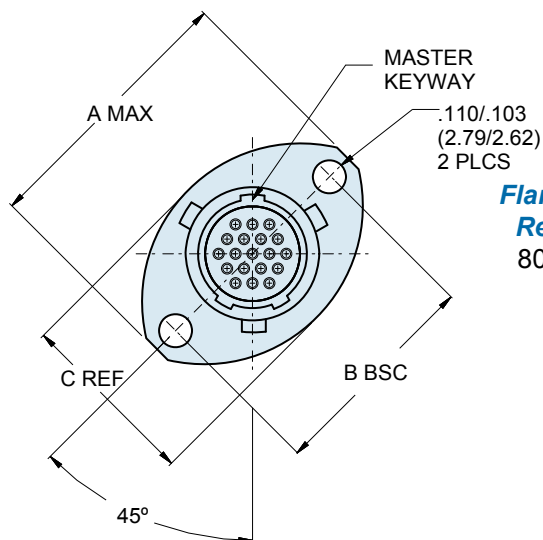

**Flange Mount
Receptacle**
803-005-02

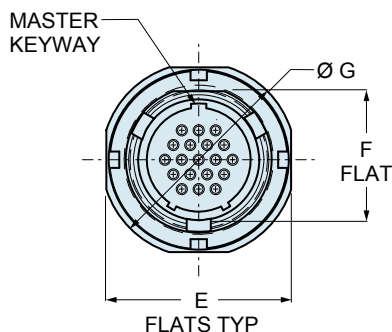
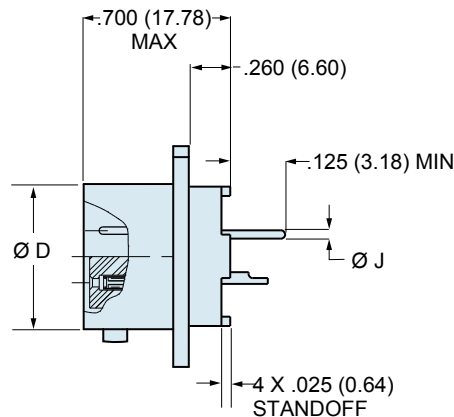

**Jam Nut
Receptacle**
803-005-07

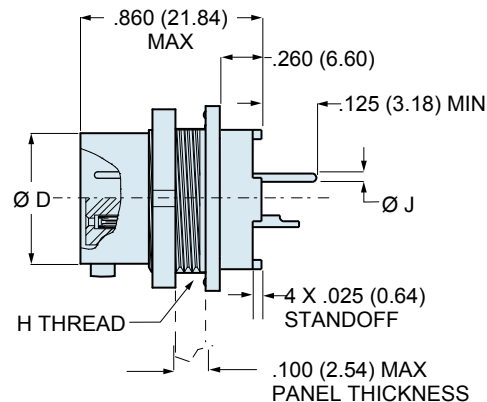

DIMENSIONS

Shell Size	A Max.		B Bsc.		C Ref.		Ø D		E Flats		F Flat		Ø G		H Thread	Ø J Tail Dia.
	In.	mm.	In.	mm.	In.	mm.	In.	mm.	In.	mm.	In.	mm.	In.	mm.		
5	.703	17.86	.513	13.03	.460	11.68	.300	7.62	.545	13.84	.350	8.89	.575	14.61	.3750-32 UNEF-2A	#23 (0.46/0.56)
6	.788	20.02	.598	15.19	.522	13.26	.362	9.19	.595	15.11	.410	10.42	.635	16.13	.4375-28 UNEF-2A	#20 (0.61/0.71)
7	.890	22.61	.708	17.98	.590	14.99	.436	11.07	.723	18.36	.536	13.61	.755	19.18	.5625-32 UN-2A	#16 (1.52/1.63)
8	1.154	29.31	.964	24.49	.668	16.97	.508	12.91	.790	18.36	.593	14.53	.755	19.18	.6250-28 UN-2A	#12 (0.92/0.96)
9	1.207	30.66	1.017	25.83	.721	18.31	.561	14.25	.790	20.07	.596	15.14	.830	21.08	.6250-28 UN-2A	#12 (2.34/2.44)
10	1.291	32.79	1.101	27.97	.795	20.19	.635	16.13	.925	21.72	.721	18.31	.890	22.61	.7500-28 UN-2A	
12	1.394	35.41	1.204	30.58	.874	22.20	.714	18.14	1.044	26.52	.845	21.46	1.078	27.38	.8750-28 UN-2A	
14	1.545	39.24	1.280	32.51	1.050	26.67	.865	21.97	1.230	31.24	1.022	25.96	1.264	32.11	1.0625-20 UN-2A	

Dimensions in inches (millimeters) and are subject to change without notice.