

Series 802 Aqua Mouse Submersible Protective Cover Ordering Information

660-087 and 660-088





Receptacle Cover

Protect Connectors From Damage – These covers prevent ingress of water and contamination. Stainless steel plug covers feature Viton® O-rings for 3500 PSI sealing. Receptacle covers have a Viton® gasket and are made from marine bronze to minimize galling.

Three Types of Attachment Rings – Choose small diameter eye fittings for panel attachment. Larger rings fit under the jam nut or over cable jackets. Split rings can be installed on fully assembled cables.

Polyurethane-Coated SST Wire Rope offers high strength, excellent abrasion resistance and good flexibility. Or, choose Teflon® jacket for high temperature exposure.

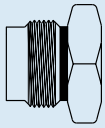
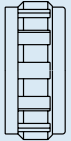
Braided Nylon Rope provides excellent flexibility and good abrasion resistance, and can be ordered with slip knot fittings for easy installation on any size cable.

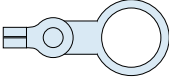
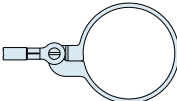
HOW TO ORDER SERIES 802 PROTECTIVE COVERS					
Sample Part Number					
660-087	- 9	U	04	- 6	
Series	Shell Size	Attachment Type	Attachment Code	Attachment Length in Inches	Alternate Key Position
 <p>660-087 Protective Cover for use with Series 802 Plugs</p>  <p>660-088 Protective Cover for use with Series 802 Receptacles</p>	-5	G Nylon Rope	Omit for attachment Types N (No Attachment) and SK (Slip Knot)	Omit for attachment Type N (No Attachment) Example "-6" equals six inch length	Omit for 660-088 receptacle covers Omit for plug connectors with standard "A" key position B C D
	-6	H			
	-7	SST Wire Rope, Teflon® Jacket	 <p>Small Ring</p>	01 – .126 (3.20) I.D.	
	-8			02 – .145 (3.68) I.D.	
	-9			04 – .188 (4.78) I.D.	
	-10	N No Attachment	 <p>Large Ring</p>	06 – .197 (5.00) I.D.	
	-12			14 – .385 (9.78) I.D.	
	-14	S SST Sash Chain		15 – .445 (11.30) I.D.	
	-15	SK Nylon Rope With Slip Knot		16 – .570 (14.48) I.D.	
	-21	T SST Wire Rope, No Jacket		17 – .635 (16.13) I.D.	
	U SST Wire Rope, Polyurethane Jacket	18 – .695 (17.65) I.D.			
	"SST" = Stainless Steel	19 – .885 (22.48) I.D.			
		20 – 1.070 (27.17) I.D.			
		21 – 1.135 (28.83) I.D.			
		 <p>Split Ring</p>	22 – 1.210 (30.73) I.D.		
			23 – 1.275 (32.39) I.D.		
			24 – 1.520 (38.61) I.D.		
			50 – .420 (10.67) I.D.		
			52 – .480 (12.19) I.D.		
			54 – .635 (16.13) I.D.		
			56 – .745 (18.92) I.D.		
		58 – .885 (22.48) I.D.			
		60 – 1.010 (25.65) I.D.			
		64 – 1.125 (28.58) I.D.			
		68 – 1.345 (34.16) I.D.			
		72 – 1.438 (36.53) I.D.			

Dimensions in inches (millimeters) and are subject to change without notice.



Series 802 Aqua Mouse Submersible Protective Cover Dimensions

660-087 and 660-088

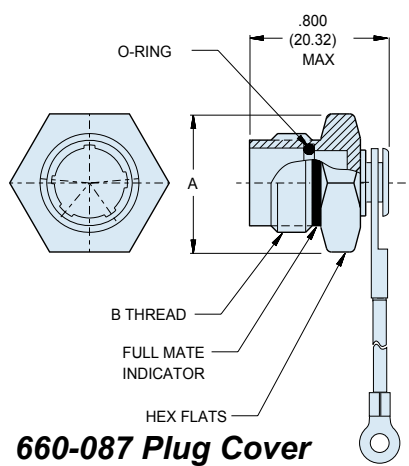

660-087 Plug Cover

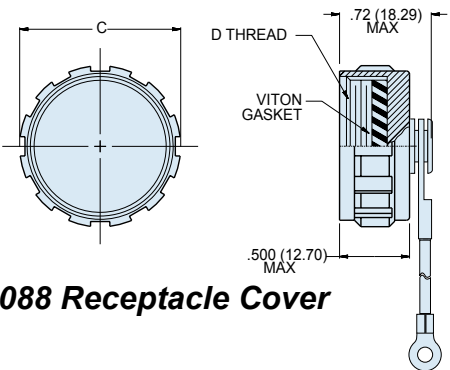

660-088 Receptacle Cover

660-087 & -088 DIMENSIONS

Shell Size	A Hex		B	C Max.		D
	In.	mm.		In.	mm.	
5	.500	12.70	.438-28 UNEF-2A	.590	14.99	.438-28 UNEF-2B
6	.625	15.88	.562-20 UN-2A	.720	18.29	.562-20 UN-2B
7	.688	17.48	.625-20 UN-2A	.780	19.81	.625-20 UN-2B
8	.750	19.05	.687-20 UN-2A	.840	21.34	.687-20 UN-2B
9	.812	20.62	.750-20 UNEF-2A	.900	22.86	.750-20 UNEF-2B
10	.875	22.23	.812-20 UNEF-2A	.970	24.89	.812-20 UNEF-2B
12	.938	23.83	.875-20 UNEF-2A	1.030	26.16	.875-20 UNEF-2B
14	1.125	28.58	1.062-20 UN-2A	1.220	30.99	1.062-20 UN-2B
15	1.188	30.18	1.125-20 UN-2A	1.280	32.51	1.125-20 UN-2B
21	1.562	39.67	1.438-20 UN-2A	1.610	40.89	1.438-20 UN-2B

MATERIALS AND FINISHES

Plug Cover	316 stainless steel, passivated
Receptacle Cover	marine bronze, unplated
O-Ring	Viton rubber
Gasket	Viton rubber
Wire, Hardware	Stainless steel, passivated

ATTACHMENT OPTIONS

Small Ring for Attaching Receptacle Covers to a Panel with a Screw	Dia. Code	Screw Size	Ring I.D.		Ring O.D.	
			In.	mm.	In.	mm.
	01	#4, M3	.126	3.20	.31	7.9
	02	#6	.145	3.68	.31	7.9
	04	#8, M4	.188	4.78	.31	7.9
	06	#10	.197	5.00	.31	7.9

Large Solid Ring for Attaching Receptacle Covers to a Jam Nut Receptacle	Dia. Code	Style 07 Jam Nut Shell Size	Style 00 Jam Nut Shell Size	Ring I.D.		Ring O.D.	
				In.	mm.	In.	mm.
	14		5,6	.385	9.78	.510	12.95
	16	5	7,8	.570	14.48	.685	17.40
	17	6	9	.635	16.13	.760	19.30
	18	7	10	.695	17.65	.820	20.82
	19	8,9,10	12	.885	22.48	1.010	25.65
	20	12	14,15	1.070	27.17	1.195	30.35
	21	14		1.135	28.83	1.270	32.26
	22	15		1.210	30.73	1.312	33.32
	24	21	21	1.520	38.61	1.522	41.20

Large Split Ring for Attaching Covers to Cables	Dia. Code	Max. Cable Dia.	Min. ID		Max. OD	
			In.	mm.	In.	mm.
	50	.410	.420	10.67	.510	12.95
	52	.470	.480	12.19	.570	14.48
	54	.625	.635	16.13	.726	18.44
	56	.735	.745	18.92	.835	21.21
	58	.875	.885	22.48	.976	24.79
	60	1.000	1.010	25.65	1.101	27.97
	64	1.115	1.125	28.58	1.215	30.86
	68	1.335	1.345	34.16	1.435	36.45
	72	1.416	1.426	36.22	1.526	38.76

Slip Knot (SK) for Attaching Covers to Cable

-55° to +100°C., black, very flexible, very good abrasion resistance, good resistance to fuels, .120" (3mm) diameter. Length includes .5" (13mm) diameter loop.

LANYARD OPTIONS

	Nylon Rope	-55° to +100°C., black, very flexible, very good abrasion resistance, good resistance to fuels, .120" (3mm) diameter
	Polyurethane Coated Wire Rope	Black polyurethane over stainless steel rope, -55° to +125°C., very flexible, excellent abrasion resistance, excellent resistance to fuels, .080" (2mm) diameter
	Teflon Jacketed Wire Rope	Translucent FEP jacket over stainless steel rope, -55° to +200°C., fair flexibility, good abrasion resistance, .100" diameter
	Sash Chain	Stainless steel, #8 chain, .240" (6mm)

Dimensions in inches (millimeters) and are subject to change without notice.