



Single-Ended or Double-Ended—These easy-to-order cable assemblies eliminate the need for expensive assembly labor. 100% tested and ready for use.

Now With Twisted Pairs—No need to create a procurement specification for Micro-D cables with twisted pairs. Glenair 177-740 cables are furnished with a full complement of white/blue twisted pair wires.

Integral Shield Termination—The connector shell has a platform to accept Band-It shield termination bands. The cable shield braid is attached directly to the connector.

Save Labor, Reduce Weight and Improve EMI Shielding with Glenair’s Micro-D Shielded Cable Assemblies

Aerospace electronics systems require higher and higher levels of protection from radiated emissions. Glenair’s fully shielded Micro-D cable assemblies meet this need. The cable shield is attached directly onto the one-piece connector shell and secured with a stainless steel **BAND-IT**® clamp. These pre-wired, 100% tested assemblies meet the requirements of MIL-DTL-83513. An optional ground spring on the pin connector assures low shell-to-shell resistance. Available with a variety of wire types and shields, Micro-D shielded assemblies can be ordered in any length, either single-ended or “back-to-back”.

Ground Spring and EMI Shielding Effectiveness – A gold-plated stainless steel ground spring on the pin connector mating face offers substantial improvement in EMI protection. The graphs compare identical connectors tested with and without ground springs.



EMI Performance with Ground Spring

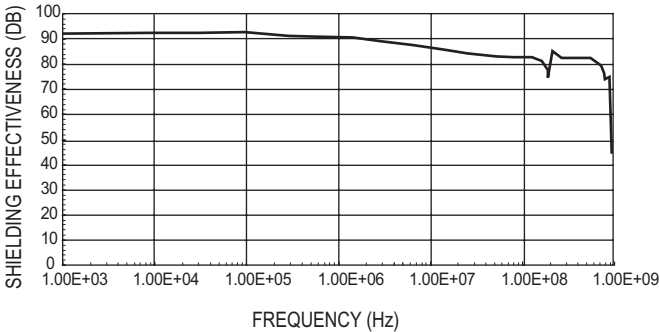

EMI Performance without Ground Spring

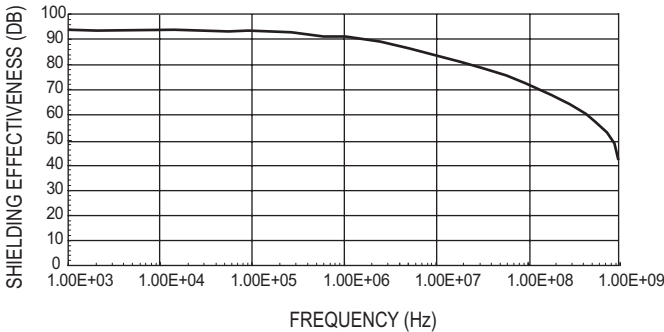

MWDM Micro-D Shielded Cable Assemblies 177-710 (Untwisted) and 177-740 (Twisted Pairs)



HOW TO ORDER SHIELDED MICRO-D CABLE ASSEMBLIES

177-710 - 2 - 25 P 4 K 1 - 24 M A G

Basic Number

- 177-710 – Untwisted Wire
- 177-740 – Twisted Pair Wire

Shell Plating

- 1 – Cadmium w/Yellow Chromate*
- 2 – Electroless Nickel
- 5 – Gold

Number of Contacts

- 9, 15, 21, 25, 31, 37, 51, 100

Contact Type

- P – Pin (Single End Plug)
- S – Socket (Single End Receptacle)
- GP – Double End Cable, Pin Connectors Both Ends
- GS – Double End Cable, Socket connectors Both Ends
- CS – Double End Cable, Pin and Socket

Wire Gage (AWG)

- 4 – #24 Gage
- 6 – #26 Gage
- 8 – #28 Gage
- 0 – #30 Gage

Wire Type

- K – Teflon® Wire Per MIL-W-22759/11 (Not available in #30 gage)
- J – Cross-Linked Tefzel® Wire Per MIL-W-22759/33

Wire Color

- 1 – White (177-710 only) Or White/Blue Pairs (177-740 Only)
- 5 – Color-Coded Per MIL-STD-681 (177-710 only)(#24 and #26 gage only)
White/Blue Twisted Pairs With Numbered Wire Markers (177-740 only)
- 7 – Ten Color Repeating (177-710 only)

Overall Length in Inches

- 6 Inch (152 mm.) Minimum

Mounting Hardware

- | | |
|---|---|
| B – No Mounting Hardware Installed | L – Male Jackscrew, Allen Head, Non-Removable |
| M – Male Jackscrew, Allen Head, Low Profile | F – Float Mount, for Front Panel Mounting |
| S – Male Jackscrew, Slot Head, Low Profile | R – Float Mount, for Rear Panel Mounting |
| P – Female Jackpost | |

Shield and Jacket Option

- N – No Shield, No Jacket
- A – Braided Shield Installed
- C – Braided Shield Installed, With E-CTFE Halar “Expando” Jacket (+150° C.)
- D – No Shield, With E-CTFE Halar “Expando” Jacket Installed (+150° C.)
- S – 100% Braided AmberStrand® Shield Installed
- T – 100% Braided AmberStrand® Shield Installed with E-CTFE Halar “Expando” Jacket (+150° C.)
- V – 75% Braided AmberStrand® Shield Installed
- Z – 75% Braided AmberStrand® Shield Installed with E-CTFE Halar “Expando” Jacket (+150° C.)

Ground Spring Option*

- N – No Ground Spring
- G – Ground Spring Installed (Pin Connectors Only)

*Ground Spring cannot be used with Cadmium Plating

MWDM Micro-D Shielded Cable Assemblies 177-710 (Untwisted) and 177-740 (Twisted Pairs)

PERFORMANCE SPECIFICATIONS

Current Rating	3 AMP
Dielectric Withstanding Voltage	600 VAC Sea Level 150 VAC 70,000 Feet
Insulation Resistance	5000 Megohms Minimum
Contact Resistance	8 Milliohms Maximum
Low Level Contact Resistance	32 Milliohms Maximum
Magnetic Permeability	2 μ Maximum
Operating Temperature	-55° C. to +150° C.
Shock	50 g.
Vibration	20 g.
Outgassing	Meets NASA Outgassing Requirements
Mating Force	(10 Ounces) X (# of Contacts)
EMI Shielding Effectiveness	50 dB Attenuation, 100 MHz to 1000 MHz

For additional performance requirements, please refer to MIL-DTL-83513

MATERIALS AND FINISHES

Connector Shell	Plating Code 1: Cadmium With Yellow Chromate Plating Code 2: Electroless Nickel Plating Code 5: Gold
Insulator	Liquid Crystal Polymer (LCP)
Interfacial Seal	Flourosilicone Rubber, Blue
Pin Contact	Beryllium Copper With 50 Microinches Gold over Nickel Plating
Socket Contact	Copper Alloy With 50 Microinches Gold Over Nickel Plating
Hardware	300 Series Stainless Steel
Wire	Type K: per MIL-W-22759/11. Silver-Plated Copper Conductor, Extruded TFE Teflon® Insulation Type J: per MIL-W-22759/33. Silver-Plated Copper Conductor, Extruded Crosslinked Tefzel® Insulation
Shield Braid	#36 AWG Nickel-Coated Copper per ASTM B355 Class 4 OFHC
Jacket	Type B: PET Expando Braided Jacket, +125° C. Type C: E-CTFE (Ethylene-Chlorotriflourethylene) Halar Expando Braided Jacket, +150° C.
Encapsulant	Epoxy Resin Hysol EE4215

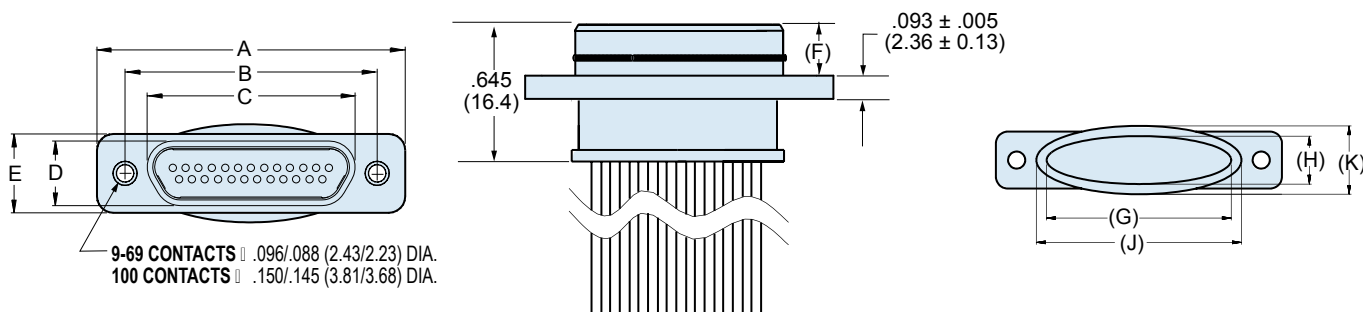

DIMENSIONS

Layout	G		H		J		K	
	In.	mm.	In.	mm.	In.	mm.	In.	mm.
9	.340	8.64	.214	5.44	.450	11.43	.324	8.23
15	.490	12.45	.214	5.44	.600	15.24	.324	8.23
21	.640	16.26	.214	5.44	.750	19.05	.324	8.23
25	.740	18.80	.214	5.44	.850	21.59	.324	8.23
31	.890	22.61	.214	5.44	1.000	25.40	.324	8.23
37	1.040	26.42	.214	5.44	1.150	29.21	.324	8.23
51	.990	24.15	.257	6.53	1.100	27.94	.367	9.32
51-2	1.390	35.31	0.214	5.44	1.460	37.08	.324	8.23
67	1.790	45.47	0.214	5.44	1.900	48.26	.324	8.23
69	1.290	32.77	0.257	6.53	1.400	35.56	.367	9.32
100	1.385	35.18	.307	7.80	1.495	37.97	.417	10.59

MWDM Micro-D Shielded Cable Assemblies 177-710 (Untwisted) and 177-740 (Twisted Pairs)



177-740 TWISTED PAIR WIRING DIAGRAM

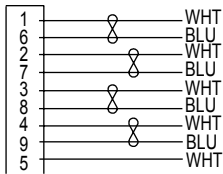

9 Contacts

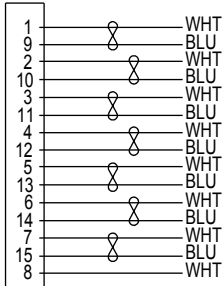

15 Contacts

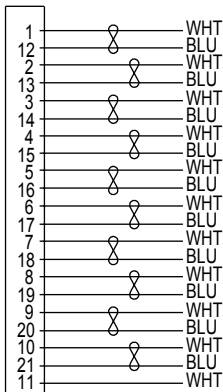

21 Contacts

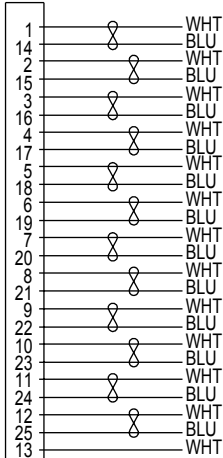

25 Contacts

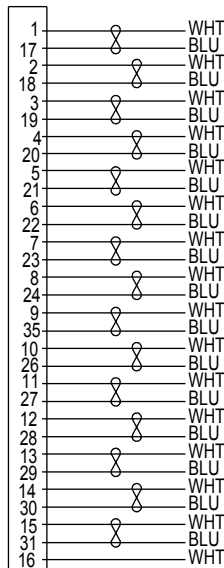

31 Contacts

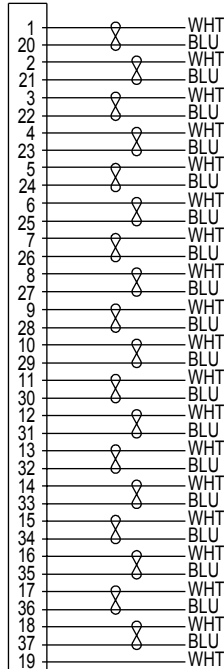

37 Contacts

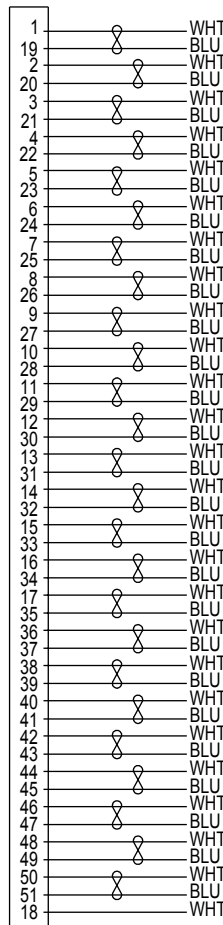

51 Contacts

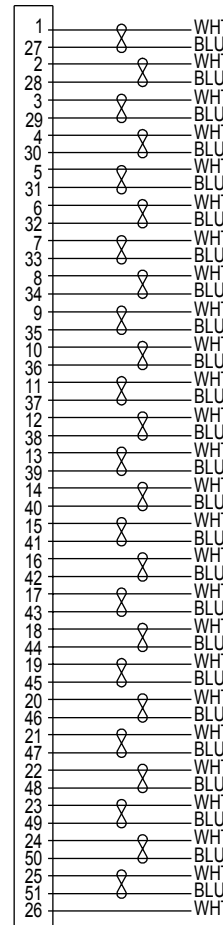

**51-2 Contacts
(Special 2-Row)**

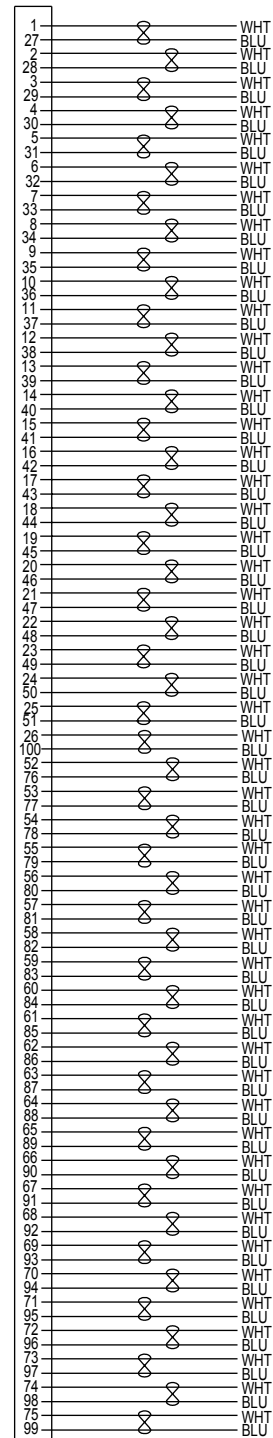

100 Contacts

