

Figure 1

Glenair Swing-Arm Offers Extremely Fast and Trouble-Free Termination of EMI Shielding:

Choose Straight, 45° or 90° angle, and tighten screws to lock arms in place. Leave the saddle clamp hardware loose.

Next, insert the wire bundle into the backshell to determine if the braid transition angle from the backshell to wire bundle is less than 45°. If it is less than 45°, build up the wire bundle with tape and re-insert wire bundle into backshell to support the transition of overall braid from the backshell to the wire bundle.

Loosely assembly the adapter to the connector and push back the backshell braid. Insert the wire bundle into the adapter and bottom it against the connector. Holding the cable, mark or tag the location where the shield support ring (Glenair Part Number 687-207) will be located. This distance may vary depending on your technique and the flexibility of the wire bundle immediately to the rear of the saddles (Figure 1).

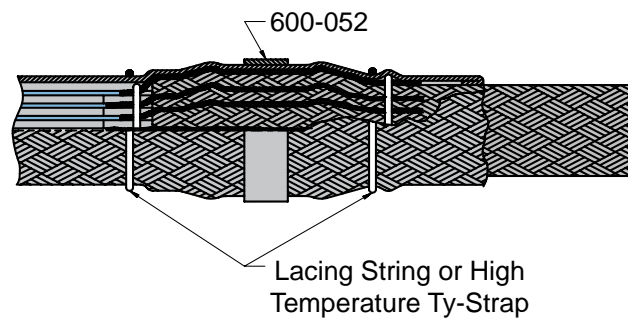

Figure 2

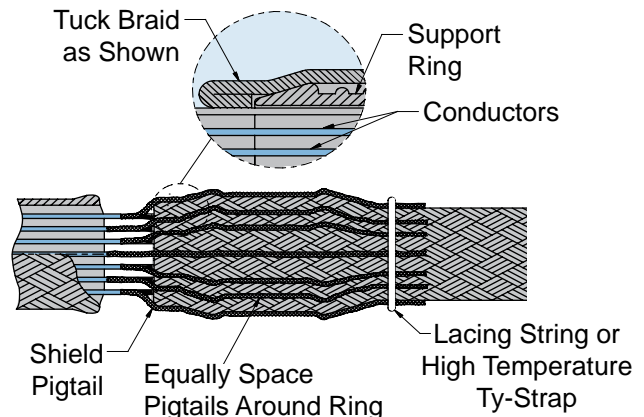
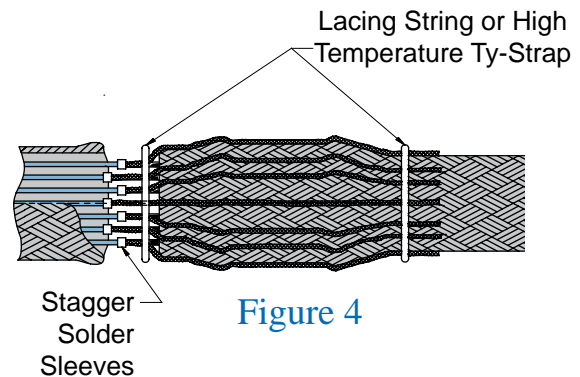
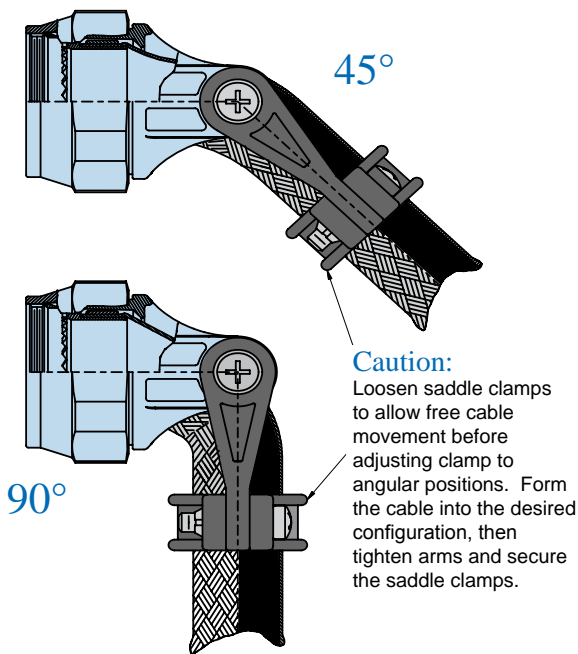

Figure 3



Composite Thermoplastic User Adjustable Swing-Arm Assembly Technical Information



Install Glenair's *Band-it*[®] band (600-052) between the lace ties onto the center of the support ring as shown in Figure 2. The hand banding tool (600-058) or pneumatic banding tool (600-067) is used for this banding process.

Next, you can wrap the shield support ring assembly with high temperature tape. Place lacing cord, high temperature tape, or high temperature plastic Ty-Straps on the braid transition to the rear of the backshell to secure the overbraid on wire bundle. If you wish, you can cover the overbraid with 102-080 braid sock.

Tighten the adapter to the connector using Glenair 600-091 composite hex coupling torque wrench and related tooling accessories to established torque values. Secure the strain relief saddle onto the wire bundle using TG69 soft jaw pliers. Torque the saddle screws to established values. You can use Teflon tape wrap or M85049/127 bushing strip as needed to cushion the braid sock under the saddle clamps.

With these few steps, your Swing-Arm strain relief installation is complete!

At the marked location, near the shield support ring, wrap tape around wire bundle for snug fit of shield support ring (Figure 1). Tape wrap is optional.

You can then slide the overall braid from the wire bundle side over the shield support ring, trimming braid ends and tucking extra braid underneath itself for a clean appearance.

For pin connectors, slide the backshell forward, and hand tighten backshell to connector. Then, evenly space shield pigtailed (Figure 3) or solder sleeve pigtailed (Figure 4) around the shield support ring. Cut the pigtailed so that the end of the pigtailed slightly beyond end of shield support ring.

Bring the shield sock from backshell and completely cover the pigtailed and support ring. Trim and fold the braid as shown in Figure 2. Lace tie the shield adjacent to support ring ends.