

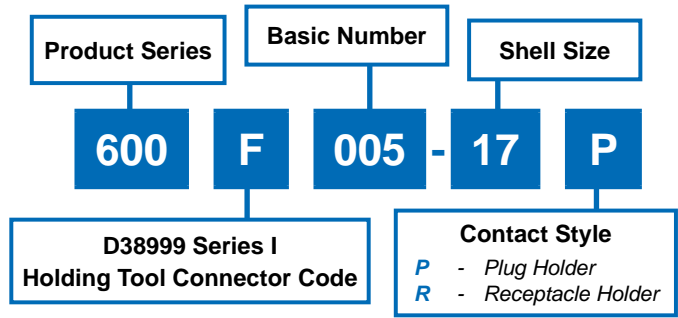

600F005
Connector Holding Tool
 MIL-DTL-38999 Series I
 Plug and Receptacle

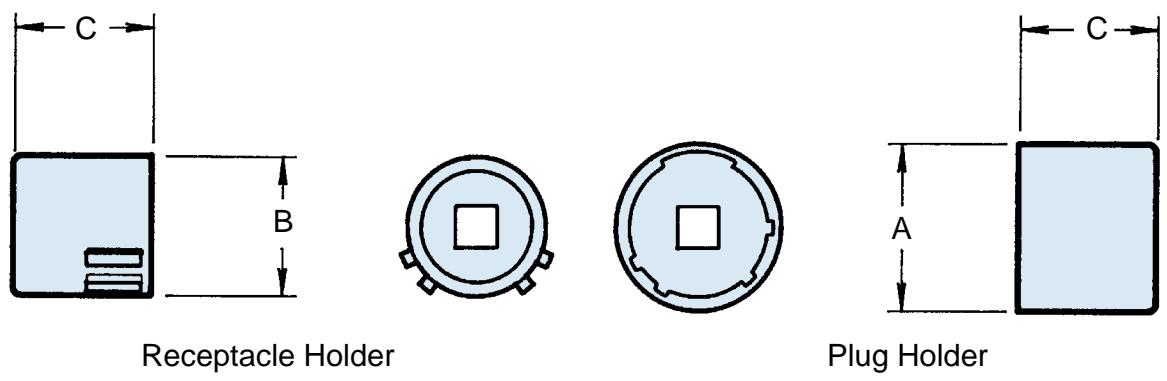

NO POLARIZATION REQUIRED



Shell Size	Max. Recommended Torque (Inch Pounds)	A Dia. Max.	B Dia. Max.	C Dim. Max.
09	40	.577 (14.7)	.438 (11.1)	1.031 (26.2)
11	40	.709 (18.0)	.566 (14.4)	1.031 (26.2)
13	40	.829 (21.1)	.678 (17.2)	1.031 (26.2)
15	40	.954 (24.2)	.803 (20.4)	1.031 (26.2)
17	40	1.107 (28.1)	.928 (23.6)	1.031 (26.2)
19	40	1.190 (30.2)	1.033 (26.2)	1.031 (26.2)
21	80	1.315 (33.4)	1.158 (29.4)	1.031 (26.2)
23	80	1.440 (36.6)	1.283 (32.6)	1.031 (26.2)
25	80	1.565 (39.8)	1.408 (35.8)	1.031 (26.2)

NOTES

1. Metric dimensions (mm) are indicated in parentheses.
2. Material: Case hardened carbon steel with electroless nickel finish.
3. Receptacle and plug holder drives: 1/4" - Shell sizes 09, 11 and 13; 3/8" - Shell sizes 15 and up.

