

MIL-DTL-26482 Type Alternate Keyway Positions



MIL-DTL
26482 Type

Insert Arrangements

Shell Size Designator	Insert Arrangement Dash Number	Contact Size and Quantity				Service Rating
		20	16	12	8	
8	8-2	2				I
	8-3	3				I
	8-4	4				I
	8-33	3				I
	8-98	3				I
10	10-6	6				I
	10-98	6				I
12	12-3		3			II
	12-8	8				I
	12-10	10				I
14	14-4			4		I
	14-5		5			II
	14-9	5		4		I
	14-12	8	4			I
	14-15	14	1			I
	14-18	18				I
	14-19	19				I
	14-22	1		4		I
16	16-8		8			II
	16-14	8		6		I
	16-23	22	1			I
	16-26	26				I
	16-95	6			2 ¹	I
	16-99	21	2			I
18	18-8			8		I
	18-11		11			II
	18-30	29	1			I
	18-32	32				I
	18-85	5		8		I
	18-88	88			4 ¹	I
20	20-16		16			II
	20-24	24				I
	20-27	27				I
	20-39	37	2			I
	20-41	41				I
	20-90	3			12	I
22	22-12			12		I
	22-19			19		I
	22-21		21			II
	22-32	32				I
	22-34	34				I
	22-41	27	14			I
	22-55	55				I
	22-95	26		6		I
22-96				7 ¹	I	
24	24-19			19		II
	24-27	11		16		I
	24-31		31			I
	24-61	61				I

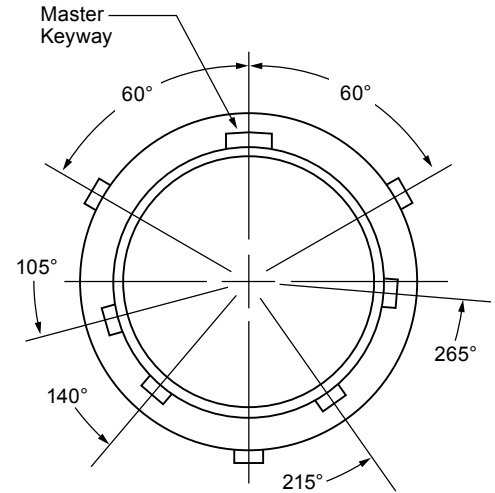

Receptacle

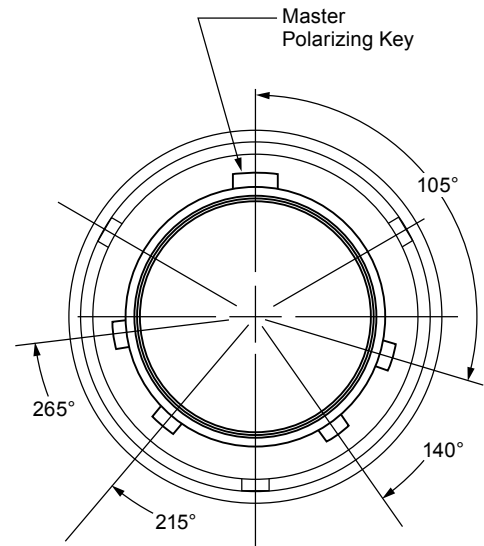

Plug

Note 1: Shielded, not applicable to Series II.

© 2009 Glenair, Inc.

CAGE CODE 06324

Printed in U.S.A.

GLENAIR, INC. • 1211 AIR WAY • GLENDALE, CA 91201-2497 • 818-247-6000 • FAX 818-500-9912

www.glenair.com

D-3

E-Mail: sales@glenair.com

D