

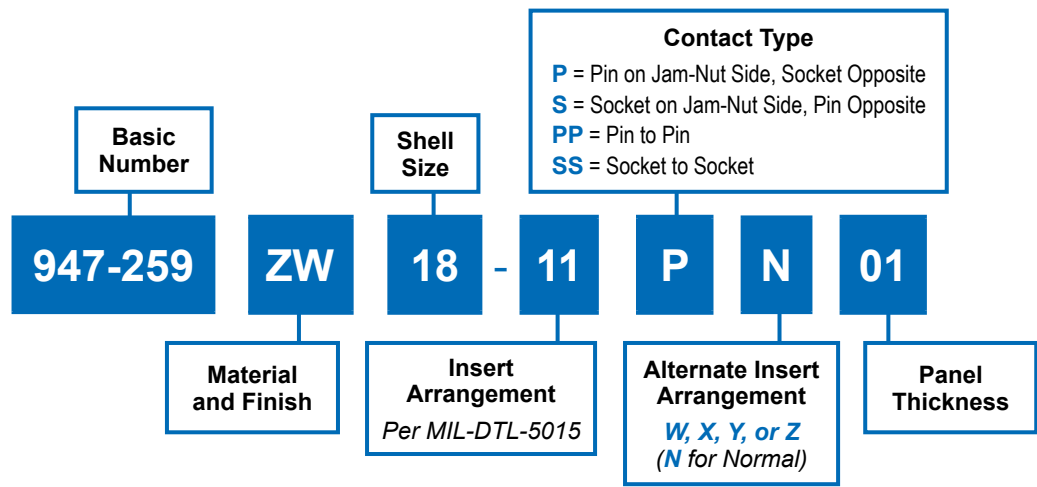

947-259
MIL-DTL-5015 Type Hermetic
Panel Mount Bulkhead Feed-Thru



HERMETIC LEAK RATE MOD CODES

Designator	Required Leak Rate
-585A	1 x 10 ⁻¹⁰ cc's Helium per second
-585B	1 x 10 ⁻⁹ cc's Helium per second
-585C	1 x 10 ⁻⁸ cc's Helium per second

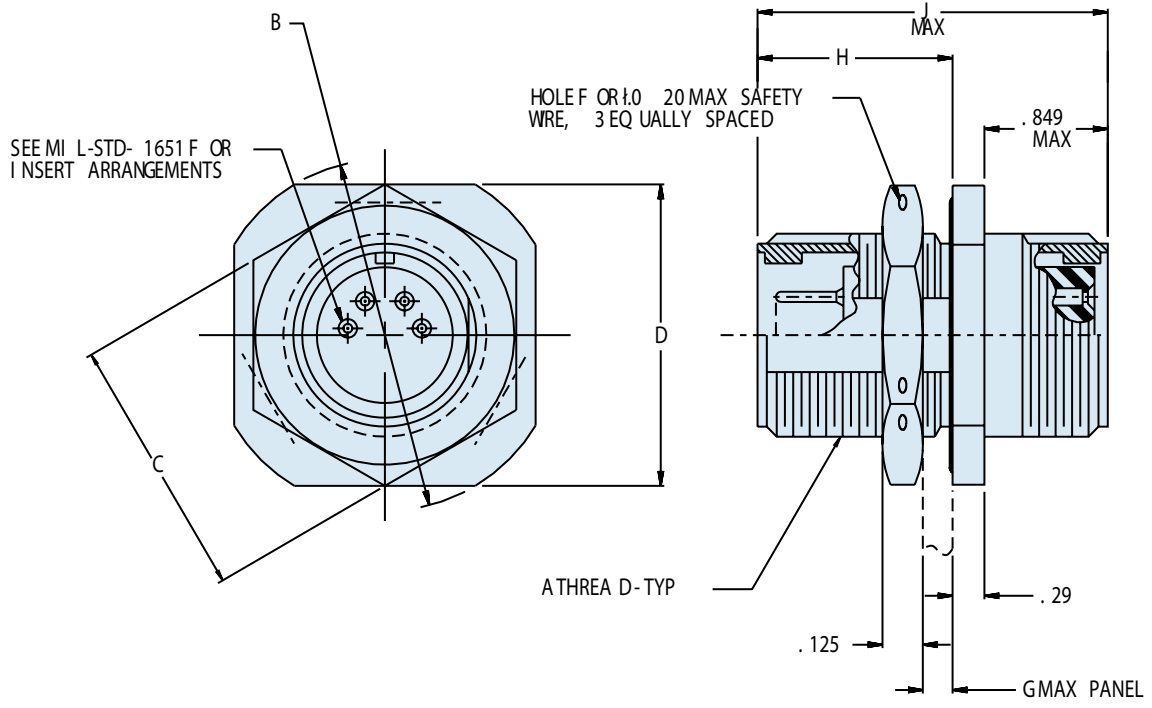

F

947-259
MIL-DTL-5015 Type Hermetic
Panel Mount Bulkhead Feed-Thru



MIL-DTL
5015 Type

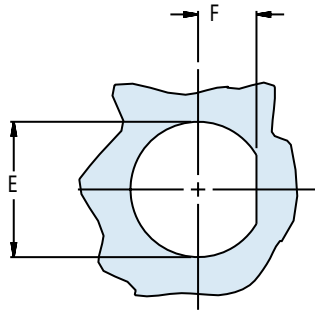

Recommended Panel Cut Out

TABLE II			
Dash No.	G Max	H	J
01	.250	1.224	2.36
02	.500	1.474	2.62

TABLE I: CONNECTOR AND CUT-OUT DIMENSIONS						
Shell Size	A Thread Class 2A	B Dia Max	C Hex	D Flats	E Dia ± .005 (0.1)	F Dim. Min.
8S	1/2-28 UNEF	1.000 (25.4)	.688 (17.5)	.875 (22.2)	.510 (13.0)	.219 (5.6)
10SL	5/8-24 UNEF	1.125 (28.6)	.812 (20.6)	1.000 (25.4)	.635 (16.1)	.281 (7.1)
12	3/4-20 UNEF	1.250 (31.8)	.938 (23.8)	1.125 (28.6)	.760 (19.3)	.344 (8.7)
12S	3/4-20 UNEF	1.250 (31.8)	.938 (23.8)	1.125 (28.6)	.760 (19.3)	.344 (8.7)
14	7/8-20 UNEF	1.375 (34.9)	1.062 (27.0)	1.250 (31.8)	.885 (22.5)	.406 (10.3)
14S	7/8-20 UNEF	1.375 (34.9)	1.062 (27.0)	1.250 (31.8)	.885 (22.5)	.406 (10.3)
16	1-20 UNEF	1.500 (38.1)	1.250 (31.8)	1.375 (34.9)	1.010 (25.7)	.469 (11.9)
16S	1-20 UNEF	1.500 (38.1)	1.250 (31.8)	1.375 (34.9)	1.010 (25.7)	.469 (11.9)
18	1 1/8-18 UNEF	1.650 (44.5)	1.375 (34.9)	1.625 (41.3)	1.135 (28.8)	.531 (13.5)
20	1 1/4-18 UNEF	1.875 (47.6)	1.500 (38.1)	1.750 (44.5)	1.260 (32.0)	.594 (15.1)
22	1 3/8-18 UNEF	2.000 (50.8)	1.625 (41.3)	1.875 (47.6)	1.385 (35.2)	.656 (16.7)
24	1 1/2-18 UNEF	2.188 (55.6)	1.750 (44.5)	2.000 (50.8)	1.510 (38.4)	.719 (18.3)
28	1 3/4-18 UNEF	2.438 (61.9)	2.000 (50.8)	2.250 (57.2)	1.760 (44.7)	.844 (21.4)
32	2-18 UNEF	2.688 (68.3)	2.250 (57.2)	2.500 (63.5)	2.010 (51.1)	.969 (24.6)
36	2 1/4-16 UN	2.938 (74.6)	2.500 (63.5)	2.750 (69.9)	2.260 (57.4)	1.089 (27.7)
40	2 1/2-16 UN	3.188 (81.0)	2.750 (69.9)	3.000 (76.2)	2.510 (63.7)	1.219 (31.0)
44	2 3/4-16 UN	3.438 (87.3)	3.000 (76.2)	3.250 (82.6)	2.760 (70.1)	1.344 (34.1)
48	3-16 UN	3.688 (93.7)	3.250 (82.6)	3.500 (88.9)	3.010 (76.5)	1.469 (37.3)



APPLICATION NOTES

- To be identified with manufacturer's name, part number and date code, space permitting.
- For pin/pin and socket/socket symmetrical layouts only, consult factory for available insert arrangements.
- Power to a given contact on one end will result in power to contact directly opposite regardless of identification letter.
- Hermeticity - Less than 1×10^{-7} cc/sec at one atmosphere.
- Electrical safety limits must be established by the user. Peak voltage, switching surge, transient voltage, etc. should be used to determine the safety application.
- Material/Finish*:
Jam-nut, lock-ring, shell - stainless steel/O.D. cadmium over nickel
Contacts - copper alloy/gold plated and alloy 52/gold plate
Insulators - High-grade rigid dielectric/N.A. and full glass
Interfacial seals and O-rings - silicone
- Metric Dimensions (mm) are indicated in parentheses.

* Additional shell materials available, including titanium and Inconel®. Consult factory for ordering information.