

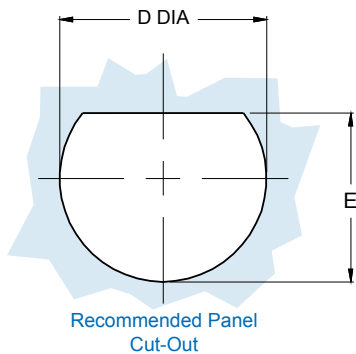

947-082
Jam Nut Mount Hermetic Bulkhead Feed-Thru
.500/.625^{inch} Panel
MIL-DTL-38999 Series III Type

B

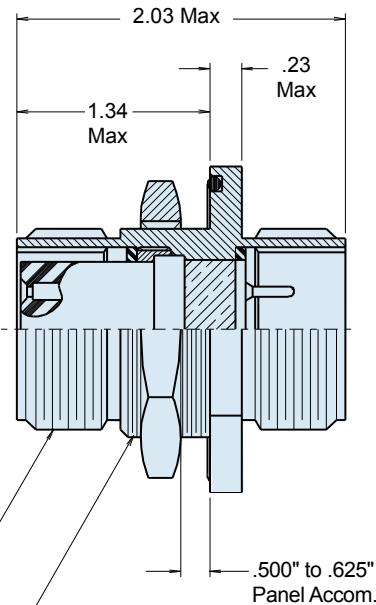
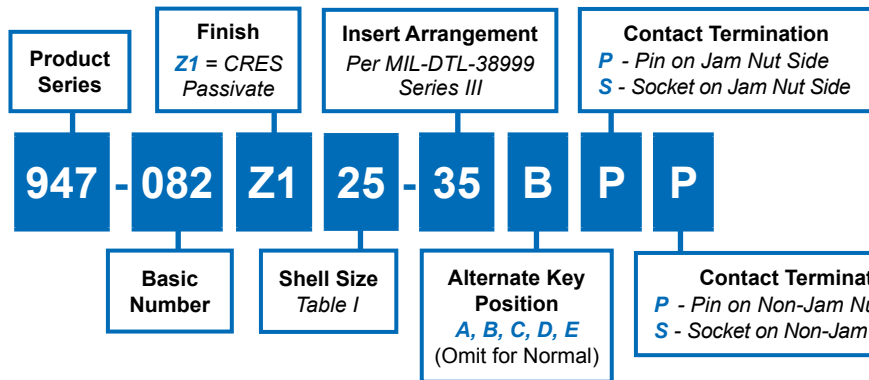

HERMETIC LEAK RATE MOD CODES	
Designator	Required Leak Rate
-585A	1 x 10 ⁻¹⁰ cc's Helium per second
-585B	1 x 10 ⁻⁹ cc's Helium per second
-585C	1 x 10 ⁻⁸ cc's Helium per second

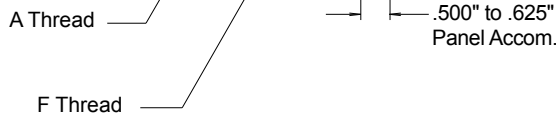
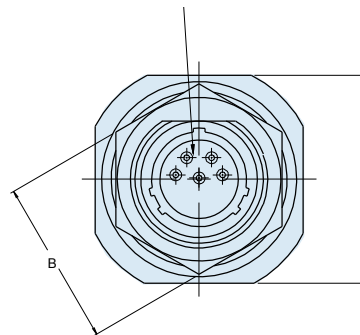

TABLE I: CONNECTOR DIMENSIONS

SHELL SIZE	A THREAD 0.1 P-0.3L-TS-2	B DIM	C DIM MAX	D DIA	E DIM	F THREAD 1-6g 0.100R
09	.6250	.875(22.2)	1.090(27.7)	.693 (17.60)	.657 (16.70)	M17
11	.7500	1.000(25.4)	1.280(32.5)	.825 (20.96)	.771 (19.59)	M20
13	.8750	1.250(31.8)	1.400(35.6)	1.010 (25.80)	.955 (24.26)	M25
15	1.0000	1.375(34.9)	1.530(38.9)	1.135 (25.65)	1.085 (27.56)	M28
17	1.1875	1.500(38.1)	1.660(42.2)	1.260 (28.83)	1.210 (30.73)	M32
19	1.2500	1.625(41.3)	1.840(46.7)	1.385 (32.01)	1.335 (33.91)	M35
21	1.3750	1.750(44.5)	1.970(50.5)	1.510 (35.18)	1.460 (37.08)	M38
23	1.5000	1.875(47.6)	2.090(53.1)	1.635 (41.53)	1.585 (40.26)	M41
25	1.6250	2.000(50.8)	2.210(56.1)	1.760 (44.70)	1.710 (43.43)	M44

Insert Arrangement per
MIL-DTL-38999 Series III
MIL-STD-1560



APPLICATION NOTES

- Power to a given contact on one end will result in power to contact directly opposite, regardless of identification letter.
 - Hermeticity = less than 1 x 10⁻⁷ cc/sec at one atmosphere. Not for use in liquid atmosphere.
 - Material/finish:
Shell, nut – CRES/passivated, carbon steel/fused tin or CRES/nickel per QQ-N-290.
 - Contacts – Gold Plated. Pin: alloy 52; Skt.: copper alloy
Insulator – fused vitreous glass/N.A.
Seals – fluorosilicone rubber/N.A.
- Metric dimensions (mm) are indicated in parentheses.