

Series 805 Mighty Mouse Triple-Start Jam Nut Mount Hermetic Receptacles

805-006-07 Connector Dimensions

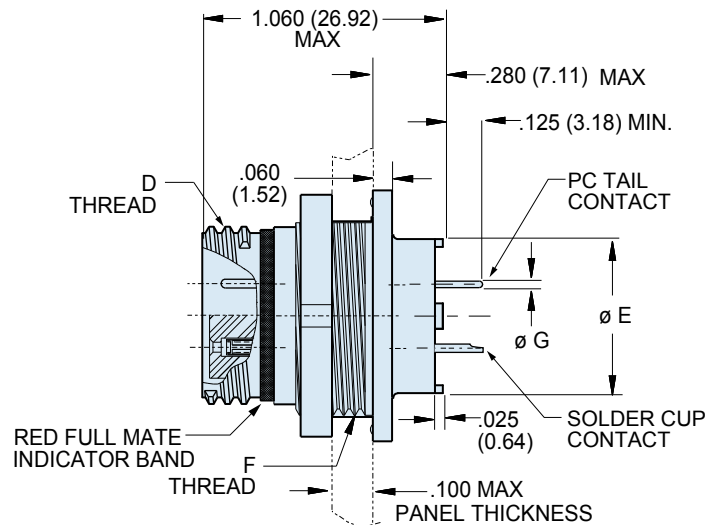
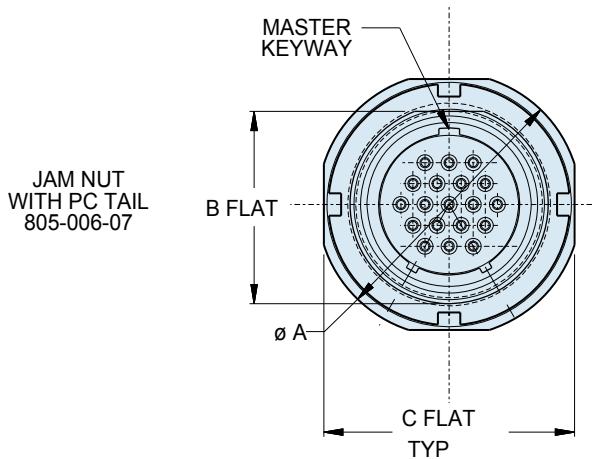

DIMENSIONS

Shell Size	ø A		B		C		D Threads	ø E		F Threads	ø G Tail Dia.
	In.	mm.	In.	mm.	In.	mm.		In.	mm.		
8	.760	19.30	.535	13.59	.730	18.54	.5000-1P-.3L-TS-2A	.330	8.38	.5625-28 UNEF-2A	#23
9	.880	22.35	.661	16.79	.850	21.59	.5625-1P-.3L-TS-2A	.432	10.97	.6875-28 UN-2A	.018/.022 (0.46/0.56)
10	.880	22.35	.661	16.79	.850	21.59	.6250-1P-.3L-TS-2A	.493	12.52	.6875-28 UN-2A	#20
11	.955	24.26	.721	18.31	.925	23.50	.6875-1P-.3L-TS-2A	.551	14.00	.7500-28 UN-2A	.024/.028 (0.61/0.71)
12	1.060	26.92	.784	19.91	1.035	26.29	.7500-1P-.3L-TS-2A	.620	15.78	.8125-28 UN-2A	#16
15	1.203	30.56	.970	24.64	1.173	29.79	.9375-1P-.3L-TS-2A	.703	17.86	1.0000-28 UN-2A	.060/.064 (1.52/1.63)
18	1.389	35.28	1.147	29.13	1.359	34.52	1.1250-1P-.3L-TS-2A	.863	21.92	1.1875-28 UN-2A	#12
19	1.450	36.83	1.221	31.01	1.420	36.07	1.1875-1P-.3L-TS-2A	.912	23.16	1.2500-28 UN-2A	.092/.096 (2.34/2.44)
23	1.705	43.31	1.470	37.34	1.675	42.55	1.4375-1P-.3L-TS-2A	1.162	29.51	1.500-25 UN-2A	

PANEL CUTOUT FOR JAM NUT RECEPTACLE

Shell Size	A Flat		ø B	
	In. ± .002	mm. ± 0.05	In. ± .005	mm. ± 0.13
8	.543	13.79	.572	14.53
9	.669	16.99	.698	17.73
10	.669	16.99	.698	17.73
11	.729	18.51	.760	19.30
12	.792	20.17	.822	20.88
15	.978	24.84	1.010	25.65
18	1.155	29.34	1.198	30.43
19	1.229	31.22	1.260	32.00
23	1.480	37.59	1.510	38.35

SERIES 805 KEY POSITIONS

Key Position	Key Rotation	
	A	B
Normal (A)	150°	210°
B	75°	210°
C	95°	230°
D	140°	275°