

**257-333**  
**Hermetic Jam Nut Receptacle**  
**with Crimp Removable Socket Contacts**  
**MIL-DTL-38999 Series III Type**

**B**

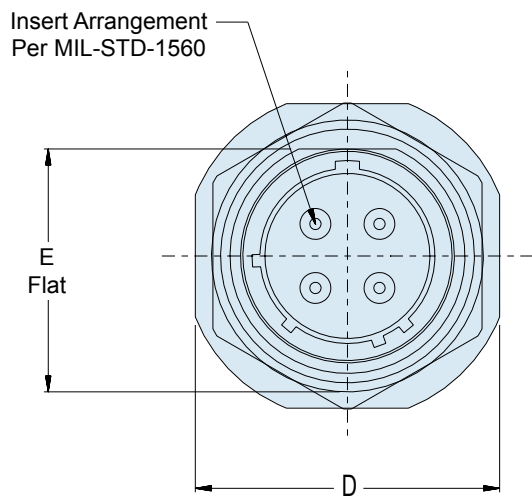

**257-333**  
**Hermetic Jam Nut Receptacle**  
**with Crimp Removable Socket Contacts**  
**MIL-DTL-38999 Series III Type**

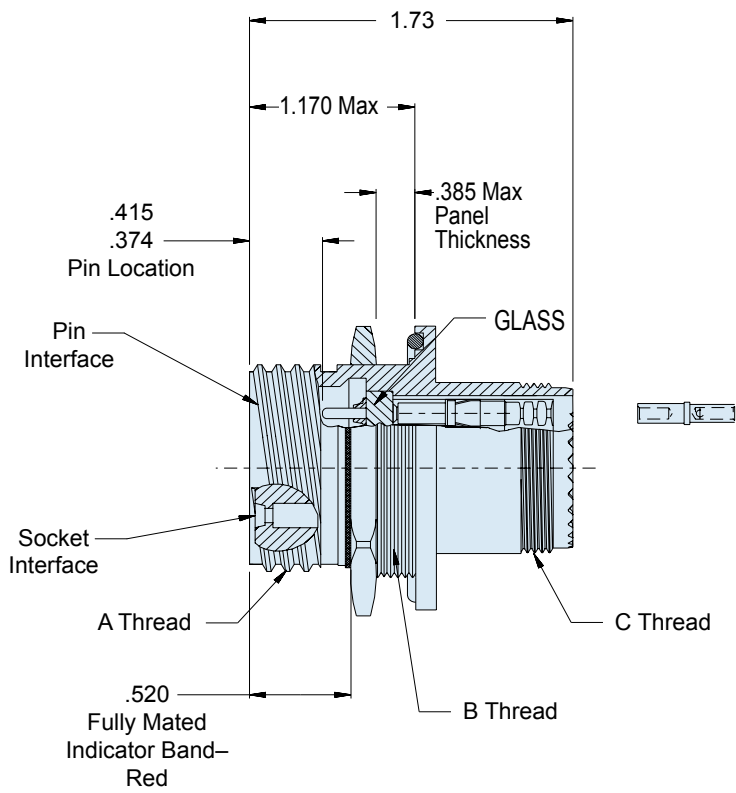
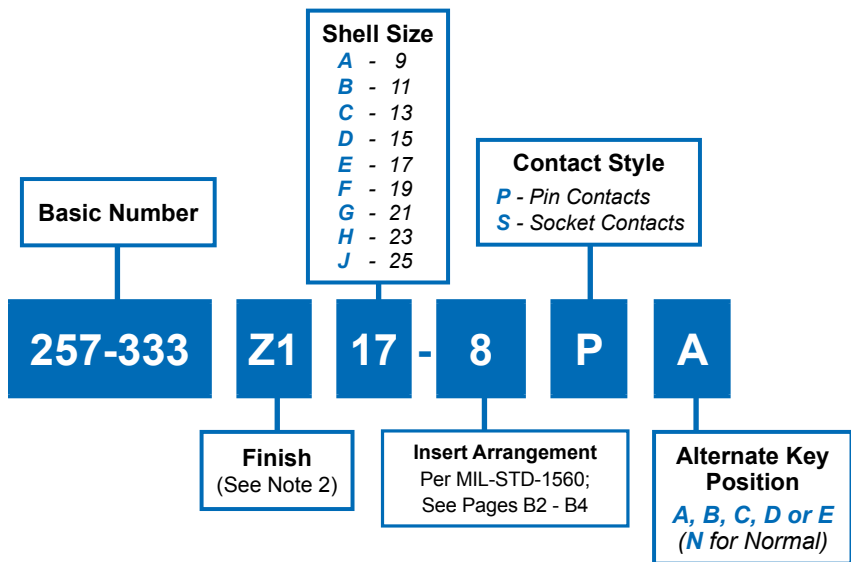

MIL-DTL  
38999 Type

**B**

**TABLE I (CONTINUED):  
CUT-OUT DIMENSIONS**

SHELL SIZE	K DIA ± .005 (0.1)	N ± .005 (0.1)
A	.693 (17.60)	.657 (16.70)
B	.825 (20.96)	.771 (19.59)
C	1.010 (25.65)	.955 (24.26)
D	1.135 (28.83)	1.085 (27.56)
E	1.260 (32.01)	1.210 (30.73)
F	1.385 (35.18)	1.335 (33.91)
G	1.510 (38.35)	1.460 (37.08)
H	1.635 (41.53)	1.585 (40.26)
J	1.760 (44.70)	1.710 (43.43)

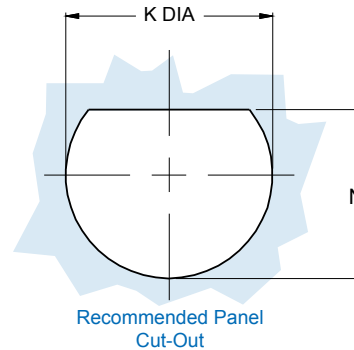

**HERMETIC LEAK RATE MOD CODES**

Designator	Required Leak Rate
-585A	1 x 10 <sup>-10</sup> cc's Helium per second
-585B	1 x 10 <sup>-9</sup> cc's Helium per second
-585C	1 x 10 <sup>-8</sup> cc's Helium per second

**TABLE I: CONNECTOR DIMENSIONS**

SHELL SIZE	SHELL SIZE CODE	A THREAD	B THREAD	C THREAD	D +/- .016 (MM)	E +/- .004-.006 (MM)
9	A	.6250-.1P.3L-TS-2A	M17x1-6g 0.100R	M12x1-6g 0.100R	1.062 (2.70)	0.651 (1.65)
11	B	.7500-.1P.3L-TS-2A	M20x1-6g 0.100R	M15x1-6g 0.100R	1.252 (3.18)	0.751 (1.91)
13	C	.8750-.1P.3L-TS-2A	M25x1-6g 0.100R	M18x1-6g 0.100R	1.374 (3.49)	0.938 (2.38)
15	D	1.000-.1P.3L-TS-2A	M28x1-6g 0.100R	M22x1-6g 0.100R	1.500 (3.81)	1.062 (2.70)
17	E	1.1875-.1P.3L-TS-2A	M32x1-6g 0.100R	M25x1-6g 0.100R	1.626 (4.13)	1.187 (3.01)
19	F	1.250-.1P.3L-TS-2A	M35x1-6g 0.100R	M28x1-6g 0.100R	1.811 (4.60)	1.312 (3.33)
21	G	1.375-.1P.3L-TS-2A	M38x1-6g 0.100R	M31x1-6g 0.100R	1.937 (4.92)	1.437 (3.65)
23	H	1.500-.1P.3L-TS-2A	M41x1-6g 0.100R	M34x1-6g 0.100R	2.063 (5.24)	1.562 (3.97)
25	J	1.625-.1P.3L-TS-2A	M44x1-6g 0.100R	M37x1-6g 0.100R	2.189 (5.56)	1.687 (4.28)

**APPLICATION NOTES**

- Assembly to be identified with Glenair's name and part number and date code, space permitting.
- Material/finishes:  
 Shell Receptacle, Jam Nut – CRES Passivated (Z1), CRES/NI (Z1)  
 Pin Contact – alloy 52 / gold plated  
 Socket Contact – copper alloy / gold plated  
 Insulator – fused vitreous glass / N.A.  
 Insulators – high grade rigid dielectric  
 Seals—fluorosilicone / N.A.  
 Hermeticity— 1x10<sup>-7</sup> cc/second
- Crimp removable socket contacts to conform to:  
 MIL-C-39029/57-358 – size 16;  
 MIL-C-39029/57-357 – size 20;  
 and MIL-C-39029/57-354 – size 22D (supplied loose)  
 Supply 1 extra contact for each size used.