

257-003 Connector Receptacle Assembly Stainless Steel Harsh Environment

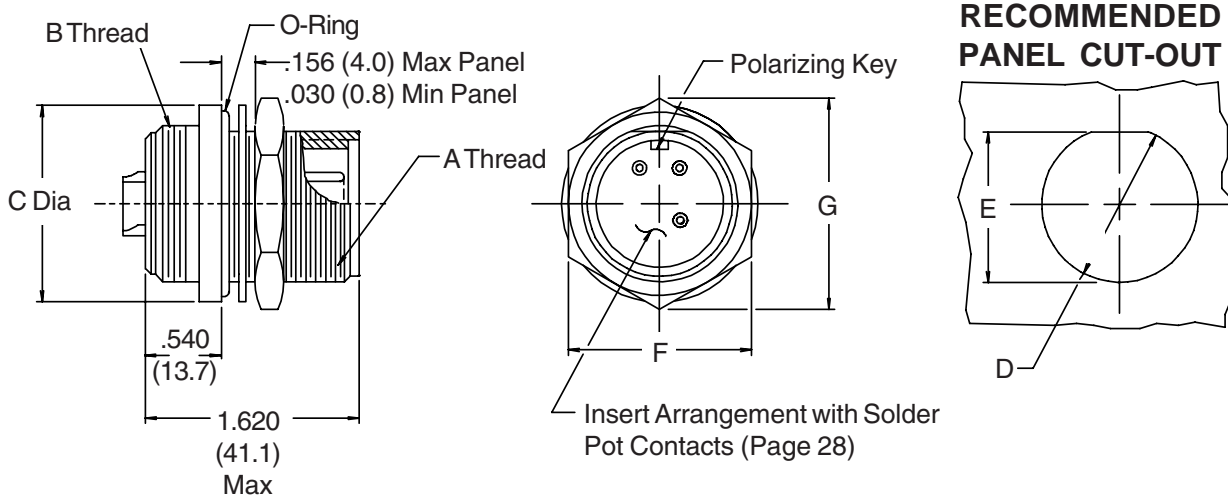
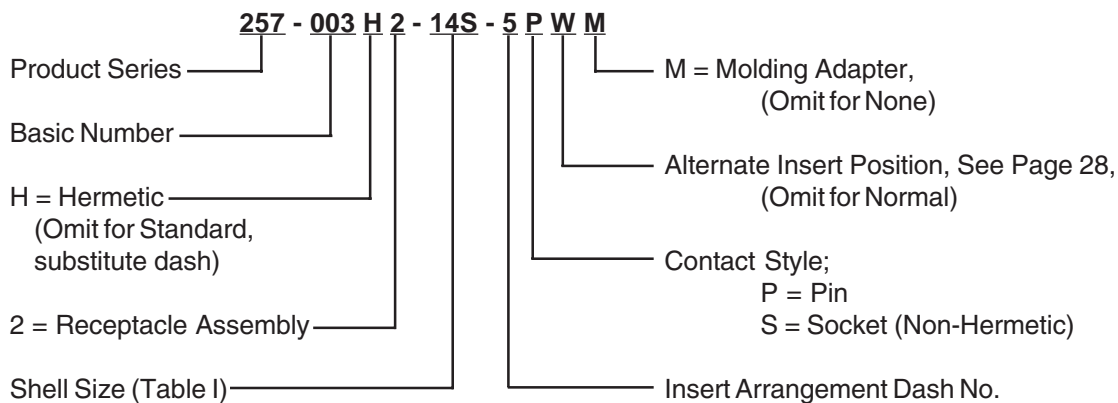

TABLE I

Shell Size	A Thread Class 2A	B Thread Class 2A	C Max	D		F Max	G Max
				+ .010 (0.3) - .000 (0)	E + .010 (0.3) - .000 (0)		
10SL	5/8 - 24 UNEF	5/8 - 24 UNEF	1.030 (26.2)	.653 (16.6)	.585 (14.9)	.812 (20.6)	.940 (23.9)
12	3/4 - 20 UNEF	3/4 - 20 UNEF	1.160 (29.5)	.760 (19.3)	.710 (18.0)	.938 (23.8)	1.090 (27.7)
14S	7/8 - 20 UNEF	7/8 - 20 UNEF	1.280 (32.5)	.885 (22.5)	.835 (21.2)	1.125 (28.6)	1.250 (31.8)
18	1 1/8 - 18 UNEF	1 1/8 - 16 UN	1.660 (42.2)	1.135 (28.8)	1.085 (27.6)	1.500 (31.8)	1.690 (42.9)
20	1 1/4 - 18 UNEF	1 1/4 - 16 UN	1.780 (45.2)	1.260 (32.0)	1.210 (30.7)	1.625 (41.3)	1.820 (46.2)
24	1 1/2 - 18 UNEF	1 1/2 - 16 UN	2.030 (51.6)	1.510 (38.4)	1.460 (37.1)	1.875 (47.6)	2.120 (53.8)
28	1 3/4 - 18 UNEF	1 3/4 - 16 UN	2.280 (57.9)	1.760 (44.7)	1.710 (43.4)	2.125 (54.0)	2.420 (61.5)

1. Metric dimensions (mm) are indicated in parentheses.
2. Electrical safety limits must be established by the user. Peak voltages, switching surges, etc., should be used to determine the safety of the application.