

For Use
with Glennair
Banding
Backshells and
Braid Socks

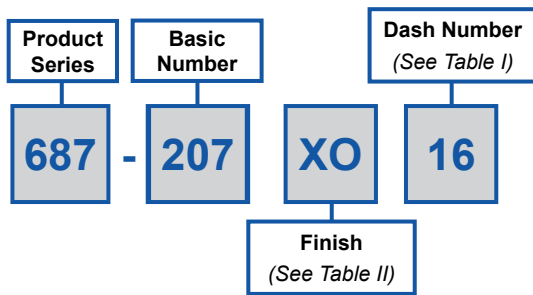
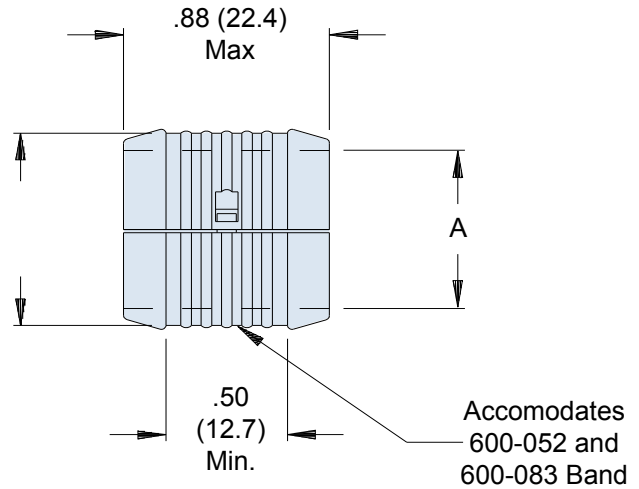
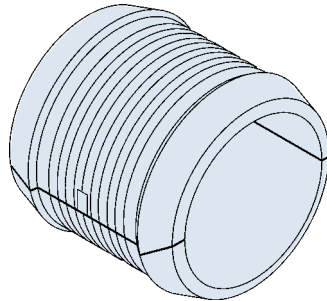

TABLE I: DASH NUMBER			
Dash No.	A Diameter ±.03 (0.8)	B Diameter ±.03 (0.8)	
04	.25 (6.4)	.36	(9.1)
06	.38 (9.7)	.49	(12.4)
08	.50 (12.7)	.61	(15.5)
10	.63 (16.0)	.74	(18.8)
12	.75 (19.1)	.86	(21.8)
14	.88 (22.4)	.99	(25.1)
16	1.00 (25.4)	1.10	(27.9)
18	1.13 (28.7)	1.24	(31.5)
20	1.25 (31.8)	1.36	(34.5)
22	1.38 (35.1)	1.49	(37.8)
24	1.50 (38.1)	1.61	(40.9)
26	1.63 (41.4)	1.74	(44.2)
28	1.75 (44.5)	1.86	(47.2)

Metric dimensions (mm) are in parentheses and are for reference only.

EXAMPLE APPLICATION

