

# Glenair MIL-DTL-38999 Series II Type Low-Profile Filter Connector with Bayonet Coupling Reference Information



MIL-DTL-38999  
Connectors

**B**

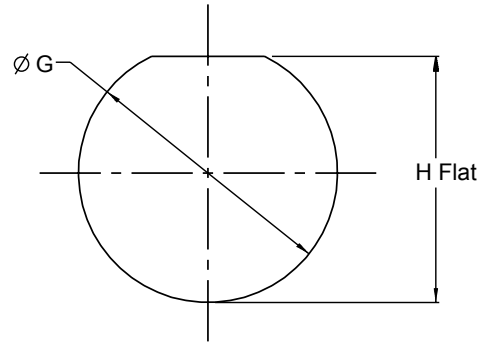
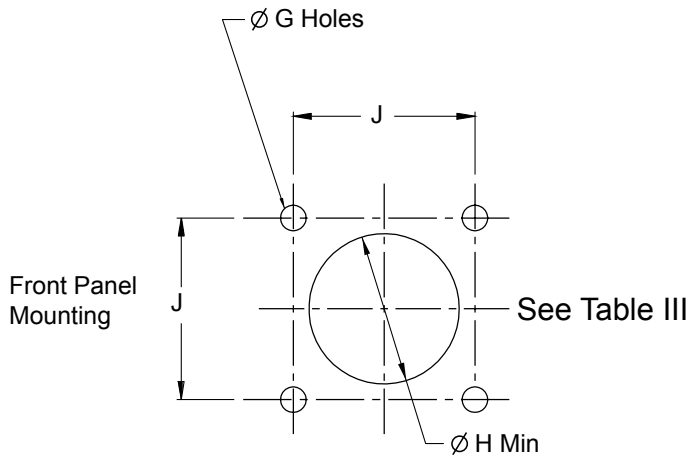

TABLE III: SQUARE FLANGE PANEL CUT-OUTS			
Shell Size	Ø G Holes	Ø H Min	Ø J BSC
8	.133 (3.4)	.570	.594
	.123 (3.1)	(14.5)	(15.1)
10	.133 (3.4)	.690	.719
	.123 (3.1)	(17.5)	(18.3)
12	.133 (3.4)	.820	.812
	.123 (3.1)	(20.8)	(20.6)
14	.133 (3.4)	.940	.906
	.123 (3.1)	(23.9)	(23.0)
16	.133 (3.4)	1.070	.969
	.123 (3.1)	(27.2)	(24.6)
18	.133 (3.4)	1.190	1.062
	.123 (3.1)	(30.2)	(27.0)
20	.133 (3.4)	1.320	1.156
	.123 (3.1)	(33.5)	(29.4)
22	.159 (4.0)	1.440	1.250
	.149 (3.8)	(36.6)	(31.8)
24	.159 (4.0)	1.570	1.375
	.149 (3.8)	(39.9)	(34.9)

PANEL IV: JAM-NUT PANEL CUT-OUTS		
SHELL SIZE	Ø G	H Flat
08	.894 (22.7)	.833 (21.2)
	.884 (22.5)	.823 (20.9)
10	1.020 (25.9)	.957 (24.3)
	1.010 (25.7)	.947 (24.1)
12	1.144 (29.1)	1.081 (27.5)
	1.134 (28.8)	1.071 (27.2)
14	1.269 (32.2)	1.206 (30.6)
	1.259 (32.0)	1.196 (30.4)
16	1.394 (35.4)	1.336 (33.9)
	1.384 (35.2)	1.326 (33.7)
18	1.520 (38.6)	1.456 (37.0)
	1.510 (38.4)	1.446 (36.7)
20	1.645 (41.8)	1.581 (40.2)
	1.635 (41.5)	1.571 (39.9)
22	1.750 (44.5)	1.706 (43.3)
	1.740 (44.2)	1.696 (43.1)
24	1.895 (48.1)	1.831 (46.5)
	1.885 (47.9)	1.821 (46.3)

## APPLICATION NOTES

- Materials/Finishes: Shells, Barrel, Coupling Nut, Jam Nut - See Table I  
Insulators - high grade rigid dielectric/N.A.  
Seals - Fluorosilicone  
PC Tail & Solder Cup contacts: 50µ" Gold over 50µ" Nickel
- Assembly to be identified with Glenair's name, part number, and date code - space permitting.
- Insert Arrangement in accordance with MIL-STD-1560.  
(Arrangement shown for reference only)
- EMI Circular Filter Receptacle connector designed to meet requirements of MIL-STD-2120 and MIL-DTL-38999, Series II.
- All contacts to have identical filter value. Other filter arrangements available, contact factory.
- Electrical Ratings: DWV- 500 VDC Min.; Standard Operating Voltage 200 Volts DC; Current Rating 5 Amps (size 22);
- Insulation Resistance: 5000 MegOhms Min. at 200 VDC.
- Operating Temperature -55°C to +125°C (Env Class Connectors)
- Other filter styles (C-L, L-C, Unbalanced PI, Multi-Stage, Multi-Value) are available, please consult the factory.
- Metric Dimensions (mm) are indicated in parentheses.