

ITS 31070 A (N0) and ITS 41070 A (N0) Rear Panel Mount Jam Nut Receptacle with Connector Accessory Mounting Threads

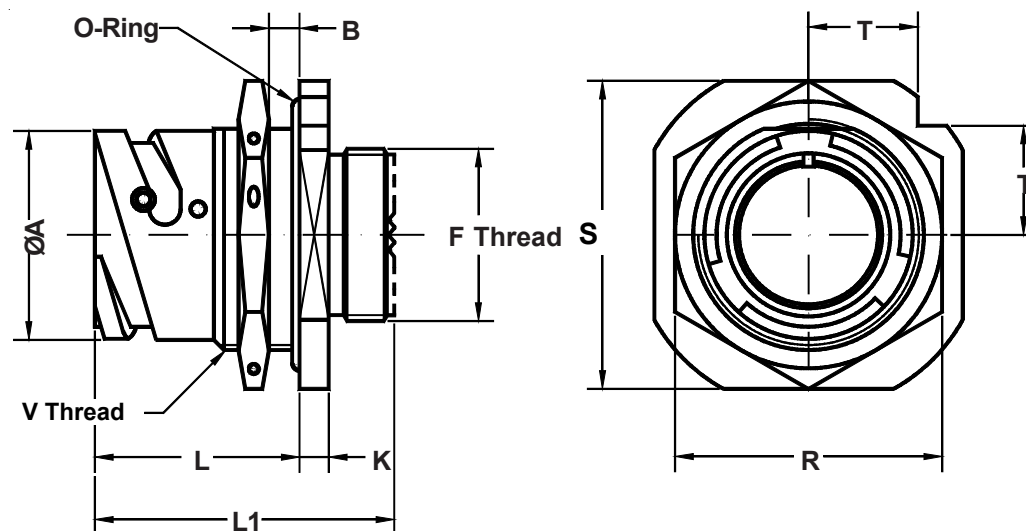
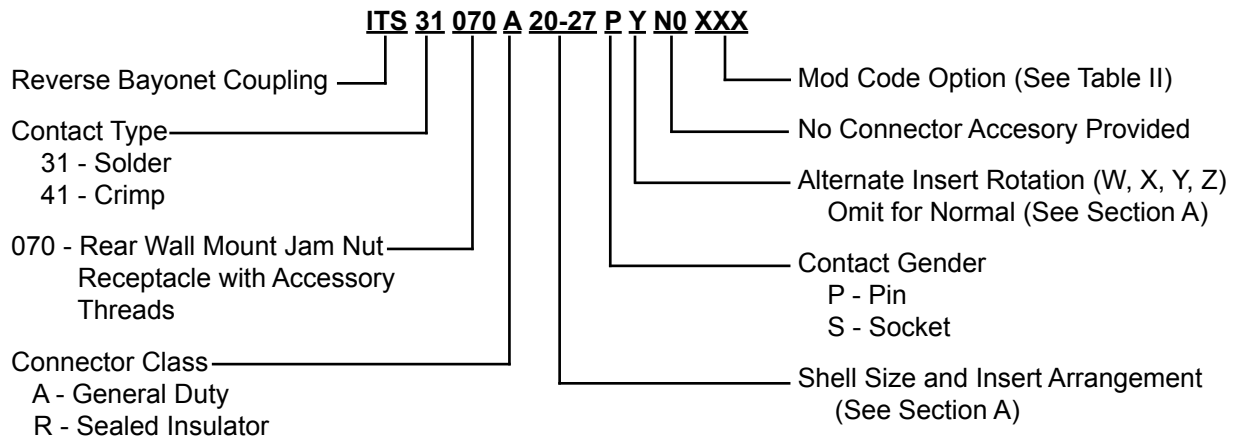

Application Notes:

1. Rear panel mount jam nut receptacle with rear threads for attachment of various backend connector accessories. No backshell provided.
2. Connector Class "A" - General Duty.
Connector Class "R" - Sealed insulator.
3. Standard materials configuration consists of aluminum alloy. For platings, see TABLE II finish options.
4. Standard contact material consists of copper alloy with silver plating or gold plating.
5. A broad range of other front and rear connector accessories are available.
See our website and/or contact the factory for complete information.
6. Standard insert material is synthetic rubber.
Add "FR" prefix to front of part number to specify fire resistant inserts.

**ITS 31070 A (N0) and ITS 41070 A (N0)
Rear Panel Mount Jam Nut Receptacle
with Connector Accessory Mounting Threads**



TABLE I: DIMENSIONS

Shell Size	ØA +0 -0.1	B		F Thread	K ±0.2	L ±0.1	L1 ±0.25	R key	S +0.2	T	V Thread
		Min.	Max.								
10 SL	18.2	2.4	5.2	0.6250 - 24UNEF	4.0	24.5	36.2	27	31.8	11.2	0.8750 - 20UNEF
14 S	24.5	2.4	7.5	0.7500 - 20UNEF	4.8	26.8	38.9	33	41.3	14.6	1.1250 - 18UNEF
16 S	27.2	2.4	7.5	0.8750 - 20UNEF	4.8	26.8	38.9	38	44.4	15.7	1.2500 - 18UNEF
16	27.2	2.4	7.5	0.8750 - 20UNEF	4.8	32.2	48.5	38	44.4	15.7	1.2500 - 18UNEF
18	30.7	2.4	9.0	1.0000 - 20UNEF	4.8	33.7	49.3	40	47.6	16.8	1.3750 - 18 UNEF
20	34.0	2.4	9.0	1.1250 - 18UNEF	4.8	33.7	49.3	44	50.8	18.0	1.5000 - 18UNEF
22	37.3	2.4	9.1	1.2500 - 18UNEF	4.8	33.7	49.3	46	54.2	20.2	1.6250 - 18UNEF
24	40.9	2.4	9.1	1.3750 - 18 UNEF	4.8	33.7	49.3	51	57.2	20.2	1.7500 - 18UNS
28	46.7	2.4	8.5	1.6250 - 18UNEF	5.6	35.2	51.9	55	63.5	22.5	2.0000 - 18UNS
32	53.4	2.4	6.5	1.8750 - 16UN	5.6	35.2	51.9	62	69.8	24.7	2.2500 - 16UN
36	59.6	2.4	8.3	2.0625 - 16UNS	5.6	35.2	51.9	71	76.2	26.9	2.5000 - 16UN
40	65.5	2.4	8.3	2.3125 - 16UNS	5.6	35.2	51.9	75	83.5	29.6	2.7500 - 16UN



TABLE II: MODIFICATION CODES

CONTACT OPTIONS	
Sym	Description
B0	Connector Less Contacts
B1	Connector with Gold Plated Contacts
Omit for standard version (Silver plated)	
FINISH OPTIONS	
Sym	Description and RoHS compliant (*)
F2	Bright Nickel Plating (*)
F6	Black Electrodeposited Paint (*)
F7	Black Zn-Co Plating (*)
F8	Olive Drab Zn-Co Plating
F11	Electroless Nickel (*)
Omit for standard version (Cadmium Olive Drab Finish)	