

ITS 31030 (A) and ITS 41030 (R)

Rear Panel Mount Square Flange Receptacle Assembly with Backshell for the Attachment of Additional Accessories

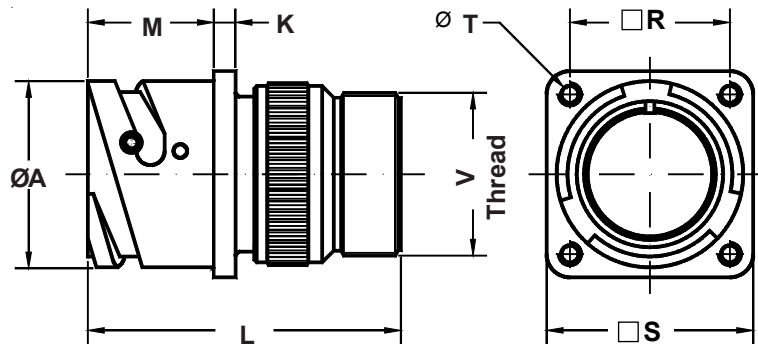

Order Cable Clamps and Sleeves Separately or Use Mod Codes (Table II) to Add Clamp to This Assembly.

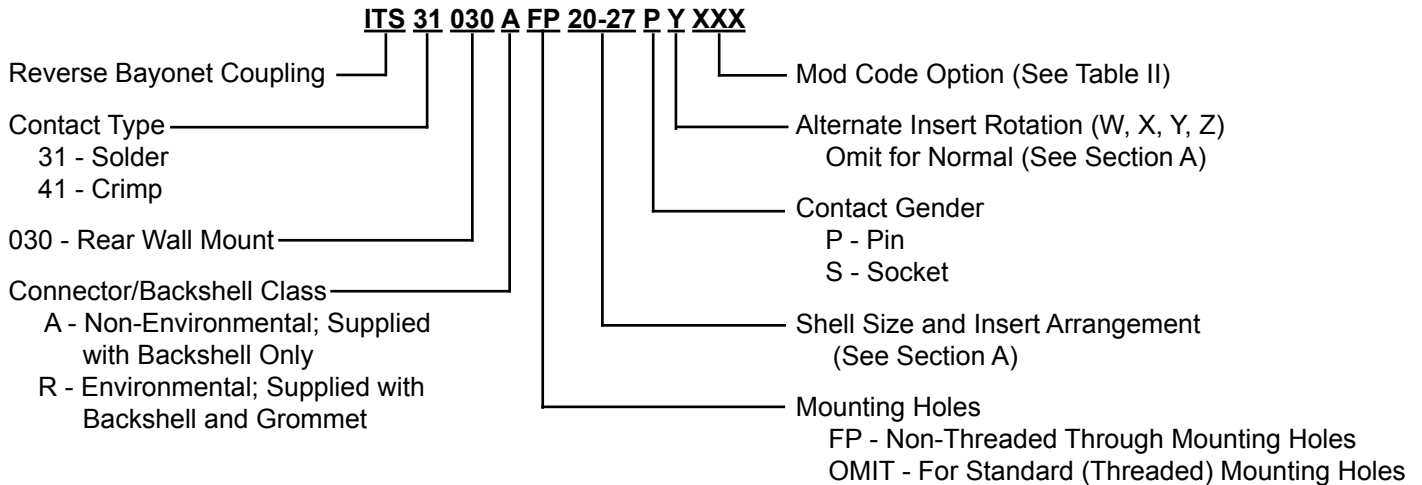
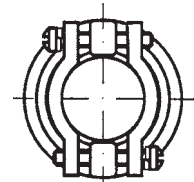

**IT 3057 C
Cable Clamp**

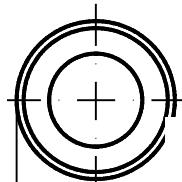

**IT 3420
Neoprene Sleeve**

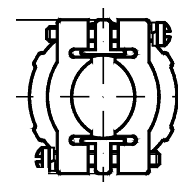

**IT 3057 A
Cable Clamp**

Application Notes:

1. Rear panel mount square flange receptacle assembly with backshell for the attachment of strain relieving cable clamps or other accessories. Threaded mounting holes standard. Optional non-threaded holes available.
2. Connector/Backshell Class "A" (non-environmental)—Not supplied with wire sealing grommet; Class "R" (environmental)—Supplied with backshell and grommet.
3. Standard materials configuration consists of aluminum alloy. For platings, see TABLE II finish options.
4. Standard contact material consists of copper alloy with silver plating or gold plating.
5. A broad range of other front and rear connector accessories are available. See our website and/or contact the factory for complete information.
6. Standard insert material is synthetic rubber. Add "FR" prefix to front of part number to specify fire resistant inserts.

ITS 31030 (A) and ITS 41030 (R)
Rear Panel Mount Square Flange Receptacle Assembly
with Backshell for the Attachment of Additional Accessories



TABLE I: DIMENSIONS

Shell Size	ØA +0 -0.1	K ±0.2	L Max.	M +0.2 -0	R ±0.1	S +0.2	T Thread	V Thread
10 SL	18.2	2.8	49.0	18.5	18.25	25.4	M4	0.6250 - 24UNEF
14 S	24.5	3.3	51.5	18.5	23.00	30.4	M4	0.7500 - 20UNEF
16 S	27.2	3.3	51.5	18.5	24.60	32.5	M4	0.8750 - 20UNEF
16	27.2	3.3	63.0	23.2	24.60	32.5	M4	0.8750 - 20UNEF
18	30.7	4.0	63.0	23.2	27.00	35.0	M4	1.0000 - 20UNEF
20	34.0	4.0	63.0	23.2	29.40	38.0	M4	1.1875 - 18UNEF
22	37.3	4.0	63.0	23.2	31.75	41.0	M4	1.1875 - 18UNEF
24	40.9	4.0	64.5	23.2	34.90	44.5	M4	1.4375 - 18UNEF
28	46.7	4.0	71.0	24.4	39.70	50.9	M5	1.4375 - 18UNEF
32	53.4	4.0	76.5	24.2	44.45	57.0	M5	1.7500 - 18UNS
36	59.6	4.0	82.0	24.2	49.20	63.5	M5	2.0000 - 18UNS
40	65.5	4.0	82.0	24.4	55.55	69.9	M5	2.2500 - 16UN

TABLE II: MODIFICATION CODES

CONTACT OPTIONS		ACCESSORY OPTIONS	
Sym	Description		
B0	Connector Less Contacts	N1	Connector with IT 3057 A cable clamp
B1	Connector with Gold Plated Contacts	N2	Connector with long backshell
Omit for standard version (Silver plated)		N5	Connector with IT 3057 C cable clamp
FINISH OPTIONS		N12	Connector with IT 3057 A cable clamp and IT 3420 neoprene sleeve
Omit for standard version (Cadmium Olive Drab Finish)		Omit for standard version	
Sym	Description and RoHS compliant (*)		
F2	Bright Nickel Plating (*)		
F6	Black Electrodeposited Paint (*)		
F7	Black Zn-Co Plating (*)		
F8	Olive Drab Zn-Co Plating		
F11	Electroless Nickel (*)		